

DO NOT SCALE DRAWING

DWG. NO. SD-5597-004

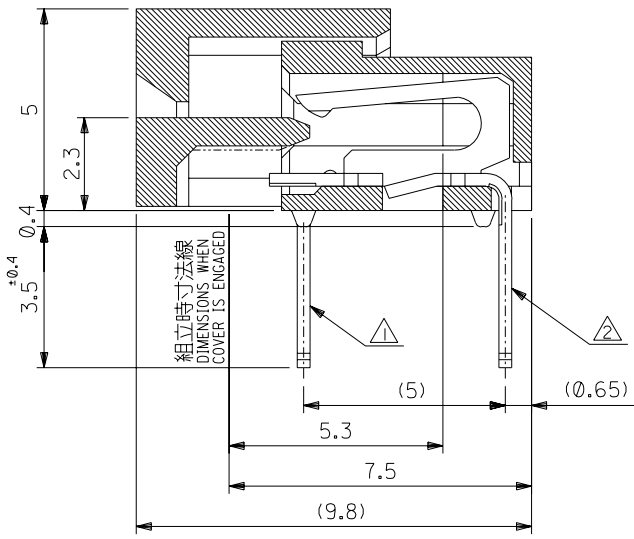
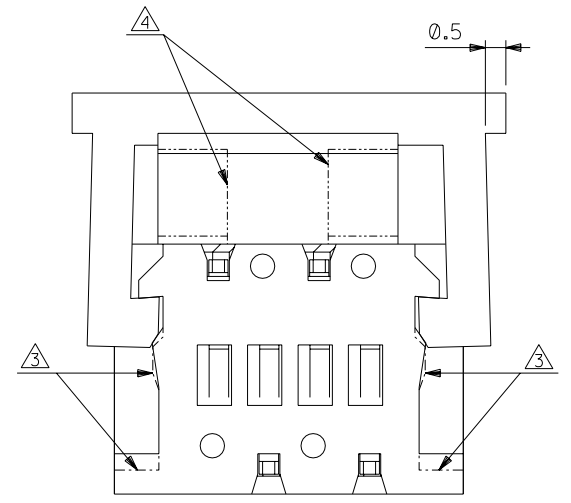
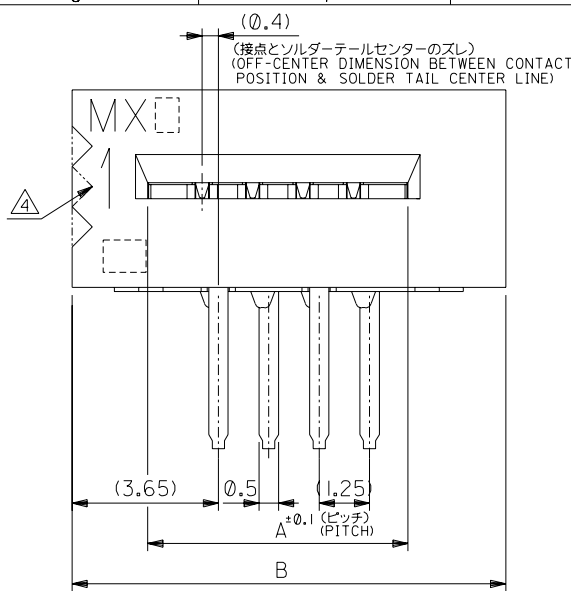

注記 NOTES

- ① MX J側を基準に奇数番目の極におけるソルダーテール。SOLDER TAIL OF ODD CKTS, MXJ MARK AS BASIC.
- ② MX J側を基準に偶数番目の極におけるソルダーテール。SOLDER TAIL OF EVEN CKTS, MXJ MARK AS BASIC.
- ③ 3極~10極に適用。APPLY FOR 3-10 CKTS.
- ④ 3極~19極に適用。APPLY FOR 3-19 CKTS.
- 5. () 内寸法は、参考値。
() DIMENSION IS FOR REFERENCE.
- 6. ソルダーテールは、先端が取付推奨穴にガイドされること。ガイドされること。
SOLDER TAILS MAY BE CHECKED BY INSERTION FOR RECOMMENDED PCB BOARD HOLES.

48.25	43.95	39-51-3343	5597-34APB	34
47.00	42.70	-3333	-33APB	33
45.75	41.45	-3323	-32APB	32
44.50	40.20	-3313	-31APB	31
43.25	38.95	-3303	-30APB	30
42.00	37.70	-3293	-29APB	29
40.75	36.45	-3283	-28APB	28
39.50	35.20	-3273	-27APB	27
38.25	33.95	-3263	-26APB	26
37.00	32.70	-3253	-25APB	25
35.75	31.45	-3243	-24APB	24
34.50	30.20	-3233	-23APB	23
33.25	28.95	-3223	-22APB	22
32.00	27.70	-3213	-21APB	21
30.75	26.45	-3203	-20APB	20
29.50	25.20	-3193	-19APB	19
28.25	23.95	-3183	-18APB	18
27.00	22.70	-3173	-17APB	17
25.75	21.45	-3163	-16APB	16
24.50	20.20	-3153	-15APB	15
23.25	18.95	-3143	-14APB	14
22.00	17.70	-3133	-13APB	13
20.75	16.45	-3123	-12APB	12
19.50	15.20	-3113	-11APB	11
18.25	13.95	-3103	-10APB	10
17.00	12.70	-3093	-09APB	9
15.75	11.45	-3083	-08APB	8
14.50	10.20	-3073	-07APB	7
13.25	8.95	-3063	-06APB	6
12.00	7.70	-3053	-05APB	5
10.75	6.45	-3043	-04APB	4
9.50	5.20	39-51-3033	5597-03APB	3
B	A	MATERIAL NO.	ENG. NO.	極数 CKT.

②64 NO. DRWN: CH'K: APPR: ②63 NO. DRWN: CH'K: APPR: ②62 NO. DRWN: CH'K: APPR: ②61 NO. DRWN: CH'K: APPR:	再作図及び変更 REDRAWN & REVISED ②60 NO. J2003-2624 DRWN: K. TOJO '03/04/17 CH'K: H. Saitoh '03/04/17 APPR: H. Saitoh '03/04/17	MATERIAL HOUSING, ACTUATOR : 材料 PBTP, UL94V-0 TERMINAL : PHOSPHOR-BRONZE THK : 0.3+	GENERAL TOLERANCES: (UNLESS SPECIFIED) 一般公差 10 UNDER 未満 ±0.2 10 OVER 以上 30 UNDER 未満 ±0.25 30 OVER 以上 ±0.3	SCALE 1:1 DESIGN UNITS 一般公差 <input checked="" type="checkbox"/> mm <input type="checkbox"/> INCH DRAWN BY & DATE K. TOJO '03/04/15 CHECKED BY & DATE H. Saitoh '03/04/17 APPROVED BY & DATE H. Saitoh '03/04/17	DIMENSIONS: <input checked="" type="checkbox"/> mm <input type="checkbox"/> INCH <input type="checkbox"/> mm ONLY <input checked="" type="checkbox"/> INCH <input type="checkbox"/> mm <input type="checkbox"/> INCH SHT 1 OF 2 REV 2 REVISION ON CAD ONLY	TITLE: 1.25 FPC Conn Assy ZIF	MOLEX MOLEX INCORPORATED	CAD FILENAME SD-5597-004.S01	MATERIAL NO. 39-51-3***3	DRAWING NO. SD-5597-004	SHEET NO. 1 OF 2	SIZE B

SD-5597-004.S01

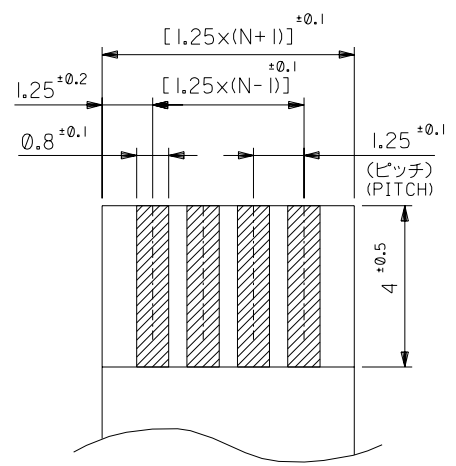

適合FPC/FFC推奨寸法
RECOMMENDED FPC/FFC
厚さ THK : 0.3 ± 0.05

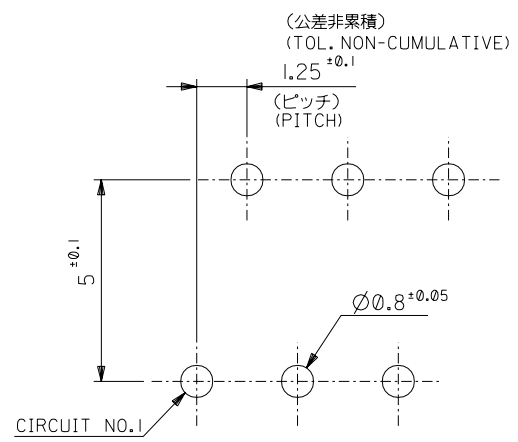

基板取付穴推奨寸法 (t=1.6)
RECOMMENDED P.C. BOARD
HOLE DIMENSION

DRAWING NO. DRAWN: CHK: APPR:	DRAWING NO. DRAWN: CHK: APPR:	DRAWING NO. DRAWN: CHK: APPR:	DRAWING NO. DRAWN: CHK: APPR:	DRAWING NO. DRAWN: CHK: APPR:	再作図及び変更 REDRAWN & REVISED DRAWING NO. J2003-2624 DRAWN: K. TOJO '03/04/17 CHK: H. Sasaki '03/04/17 APPR: H. Sasaki '03/04/17	MATERIAL 材料	GENERAL TOLERANCES: (UNLESS SPECIFIED) 一般公差	SCALE	DESIGN UNITS	DIMENSIONS: <input type="checkbox"/> mm <input type="checkbox"/> INCH <input checked="" type="checkbox"/> mm ONLY	SHT	REV		
						SEE SHEET I	10 UNDER 未満	///	mm <input checked="" type="checkbox"/> INCH				PROJECTION	PROJECTION
DRAWING NO. DRAWN: CHK: APPR:	DRAWING NO. DRAWN: CHK: APPR:	DRAWING NO. DRAWN: CHK: APPR:	DRAWING NO. DRAWN: CHK: APPR:	DRAWING NO. DRAWN: CHK: APPR:	再作図及び変更 REDRAWN & REVISED DRAWING NO. J2003-2624 DRAWN: K. TOJO '03/04/17 CHK: H. Sasaki '03/04/17 APPR: H. Sasaki '03/04/17	FINISH 仕上げ	10 OVER 30 UNDER 未満	///	///	TITLE: 1.25 FPC Conn Assy ZIF	MOLEX INCORPORATED	SHEET NO. 2 OF 2		
						SEE SHEET I	30 OVER 以上	///	///				APPROVED BY & DATE H. Sasaki '03/04/17	MATERIAL NO. SD-5597-004.S02
DRAWING NO. DRAWN: CHK: APPR:	DRAWING NO. DRAWN: CHK: APPR:	DRAWING NO. DRAWN: CHK: APPR:	DRAWING NO. DRAWN: CHK: APPR:	DRAWING NO. DRAWN: CHK: APPR:	再作図及び変更 REDRAWN & REVISED DRAWING NO. J2003-2624 DRAWN: K. TOJO '03/04/17 CHK: H. Sasaki '03/04/17 APPR: H. Sasaki '03/04/17	WIRE RANGE 適用電線範囲	ANGLE 角度	///	///	MATERIAL NO. 39-51-3**3				
						///	±3°	///	///	DRAWING NO. SD-5597-004				
REV						INS. RANGE 被覆外径	CAD FILENAME SD-5597-004.S02			MATERIAL NO. 39-51-3**3				
						DRAWING NO. SD-5597-004			DRAWING NO. SD-5597-004			DRAWING NO. SD-5597-004		

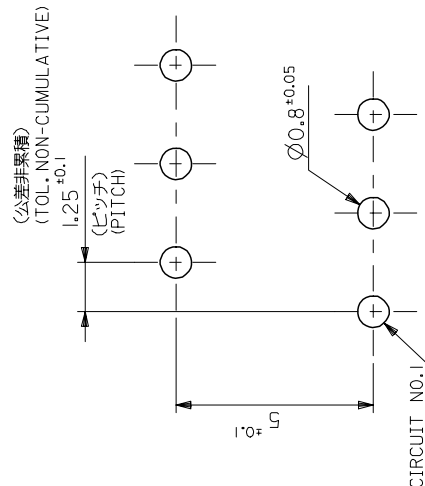
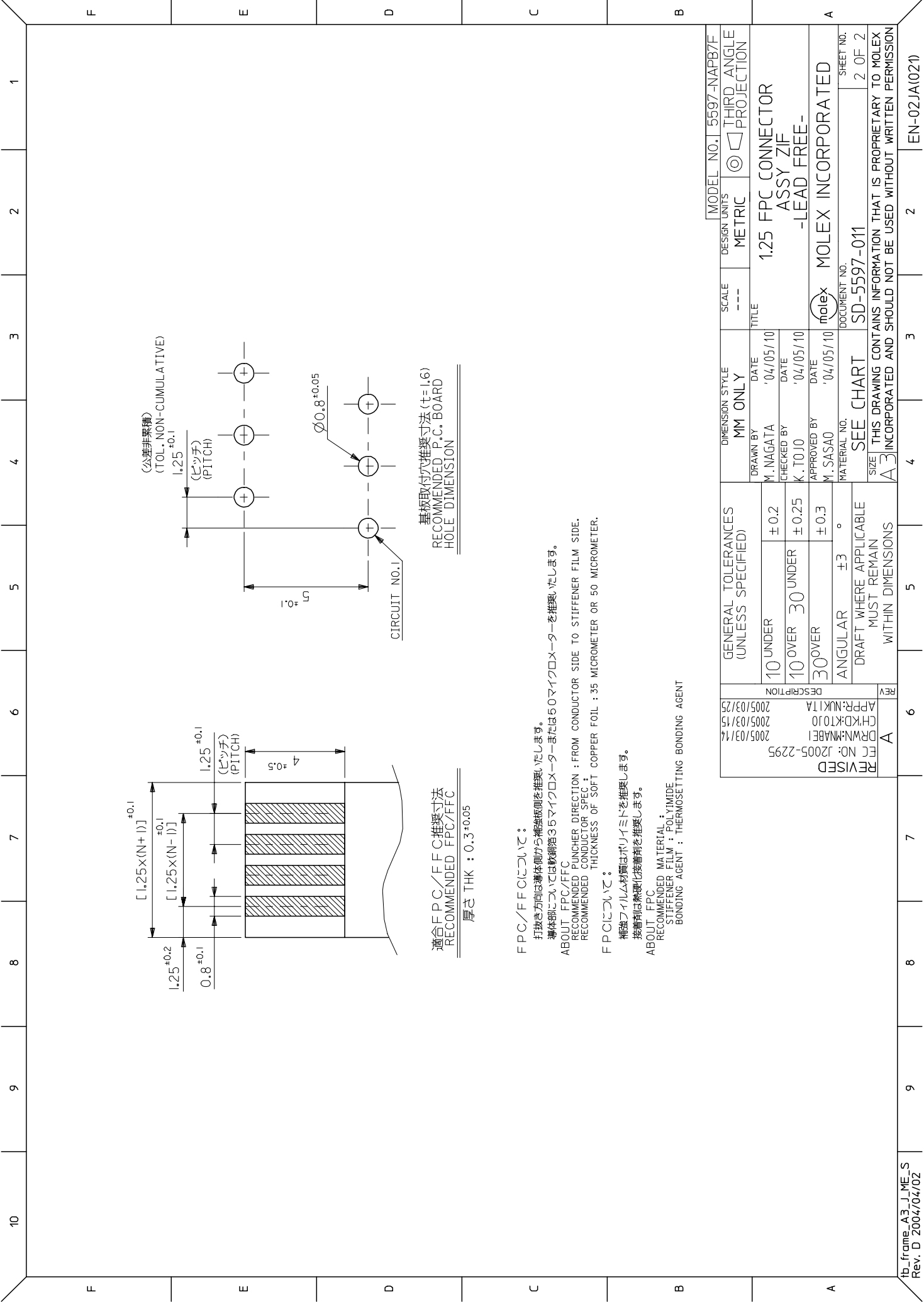

基板取付穴推奨寸法 (±=I.6)
RECOMMENDED P.C. BOARD
HOLE DIMENSION

適合FPC/FPC推奨寸法
RECOMMENDED FPC/FPC
厚さ THK : 0.3 ± 0.05

FPC/FPCについて：
打抜き方向は導体側から補強材側を推奨いたします。
導体部については教部第3.6マイクロメーターまたは5.0マイクロメーターを推奨いたします。
ABOUT FPC/FPC
RECOMMENDED PUNCHER DIRECTION : FROM CONDUCTOR SIDE TO STIFFENER FILM SIDE.
RECOMMENDED CONDUCTOR SPEC :
THICKNESS OF SOFT COPPER FOIL : 35 MICROMETER OR 50 MICROMETER.
FPCについて：
補強フィルム材質はポリイミドを推奨します。
接着剤は熱硬化接着剤を推奨します。
ABOUT FPC
RECOMMENDED MATERIAL :
STIFFENER FILM : POLYIMIDE
BONDING AGENT : THERMOSETTING BONDING AGENT

MODEL NO. 5597-NAPB7F		DESIGN UNITS	SCALE	DIMENSION STYLE	THIRD ANGLE PROJECTION	
METRIC		---	---	MM ONLY	1.25 FPC CONNECTOR ASSY ZIF -LEAD FREE-	
DRAWN BY		DATE	TITLE			
M. NAGATA		'04/05/10	1.25 FPC CONNECTOR ASSY ZIF -LEAD FREE-			
CHECKED BY		DATE	DOCUMENT NO.			
K. TOJO		'04/05/10	SD-5597-011			
APPROVED BY		DATE	SHEET NO.			
M. SASAO		'04/05/10	2 OF 2			
MATERIAL NO.		MOLEX INCORPORATED				
SEE CHART		THIS DRAWING CONTAINS INFORMATION THAT IS PROPRIETARY TO MOLEX INCORPORATED AND SHOULD NOT BE USED WITHOUT WRITTEN PERMISSION				
SIZE		A3				