

Silicon Phototransistor

Description

TEMT1000 series are high speed and high sensitive silicon NPN epitaxial planar phototransistors in SMD package with dome lens. Due to integrated Daylight filter devices are sensitive for IR radiation only.

Features

- High photo sensitivity
- Fast response times
- Angle of half sensitivity $\phi = \pm 15^\circ$
- Daylight filter matched to IR Emitters ($\lambda = 870 \text{ nm to } 950 \text{ nm}$)
- Versatile terminal configurations
- Matched IR Emitter series: TSML1000

Applications

Detector in electronic control and drive circuits

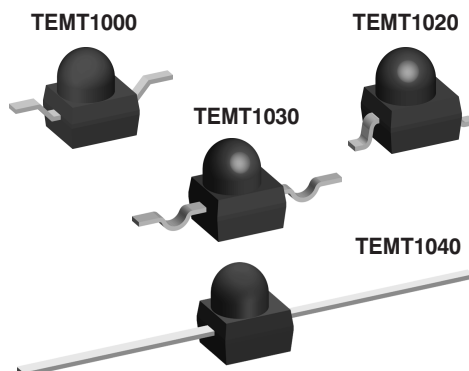

16757

IR Detector for Daylight application
Photo interrupters
Counter
Encoder

Absolute Maximum Ratings

$T_{amb} = 25^\circ\text{C}$, unless otherwise specified

Parameter	Test condition	Symbol	Value	Unit
Emitter Collector Voltage		V_{ECO}	5	V
Collector Current		I_C	50	mA
Peak Collector Current	$t_p/T = 0.5, t_p \leq 10 \text{ ms}$	I_{CM}	100	mA
Total Power Dissipation	$T_{amb} \leq 55^\circ\text{C}$	P_{tot}	100	mW
Junction Temperature		T_j	100	$^\circ\text{C}$
Storage Temperature Range		T_{stg}	- 40 to + 100	$^\circ\text{C}$
Operating Temperature Range		T_{amb}	- 40 to + 85	$^\circ\text{C}$
Soldering Temperature	$t \leq 5 \text{ s}$	T_{sd}	<260	$^\circ\text{C}$
Thermal Resistance Junction/Ambient		R_{thJA}	400	K/W

Basic Characteristics

$T_{amb} = 25^\circ\text{C}$, unless otherwise specified

Parameter	Test condition	Symbol	Min	Typ.	Max	Unit
Collector Emitter Voltage	$I_C = 1 \text{ mA}$	V_{CEO}	70			V
Collector Dark Current	$V_{CE} = 20 \text{ V}, E = 0$	I_{CEO}		1	200	nA
Collector Emitter Capacitance	$V_{CE} = 5 \text{ V}, f = 1 \text{ MHz}, E=0$	C_{CEO}		3		pF
Angle of Half Sensitivity		ϕ		± 15		deg
Wavelength of Peak Sensitivity		λ_p		950		nm
Range of Spectral Bandwidth		$\lambda_{0.5}$		750 to 980		nm
Collector Emitter Saturation Voltage	$E_e = 1 \text{ mW/cm}^2,$ $\lambda = 950 \text{ nm}, I_C = 0.1 \text{ mA}$	V_{CEsat}			0.3	V
Turn-On Time	$V_S = 5 \text{ V}, I_C = 5 \text{ mA},$ $R_L = 100 \Omega$	t_{on}		2.0		μs

Parameter	Test condition	Symbol	Min	Typ.	Max	Unit
Turn-Off Time	$V_S = 5\text{ V}$, $I_C = 5\text{ mA}$, $R_L = 100\ \Omega$	t_{off}		2.3		μs
Cut-Off Frequency	$V_S = 5\text{ V}$, $I_C = 5\text{ mA}$, $R_L = 100\ \Omega$	f_c		180		kHz
Collector Light Current	$E_e = 1\text{ mW/cm}^2$, $\lambda = 950\text{ nm}$, $V_{CE} = 5\text{ V}$	I_{ca}	2	7.0		mA

Typical Characteristics ($T_{amb} = 25\text{ }^\circ\text{C}$ unless otherwise specified)

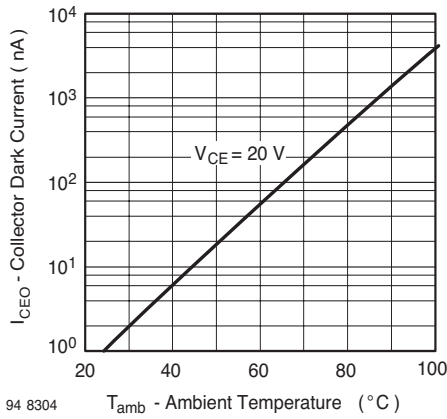

Figure 1. Collector Dark Current vs. Ambient Temperature

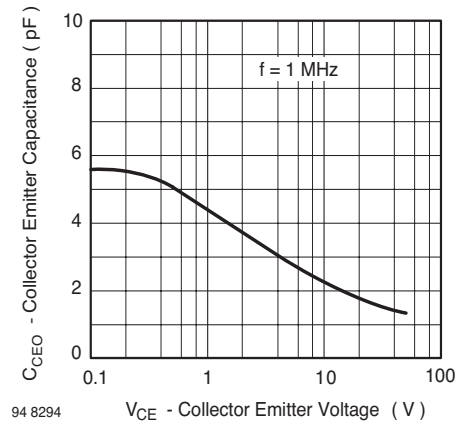

Figure 3. Collector Emitter Capacitance vs. Collector Emitter Voltage

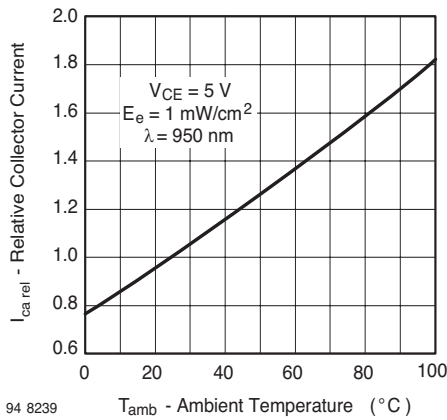

Figure 2. Relative Collector Current vs. Ambient Temperature

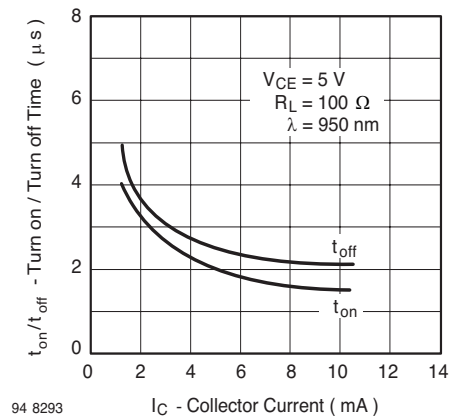
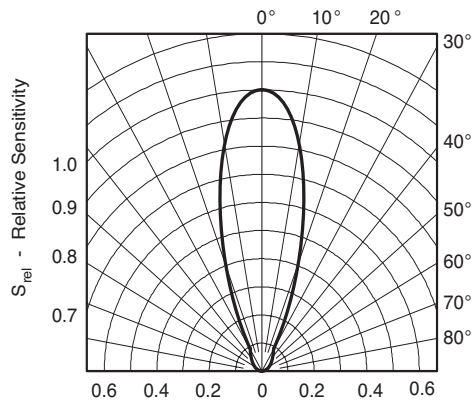

Figure 4. Turn On/Turn Off Time vs. Collector Current



94 8248

Figure 5. Relative Radiant Sensitivity vs. Angular Displacement

TEMT1000/1020/1030/1040



Vishay Semiconductors

Package Dimensions in mm TEMT1000

Drawing-No.: 6.544-5326.01-4
Issue: 4; 02.04.03

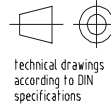
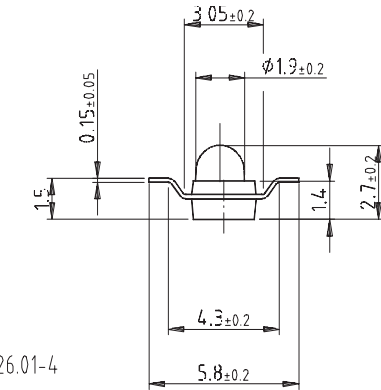

All dimensions in mm

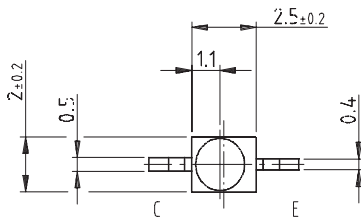

Solder pad proposal

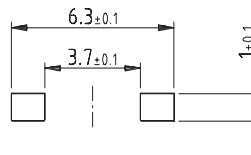

16104

Package Dimensions in mm TEMT1020

Drawing-No.: 6.544-5325.01-4
Issue: 4; 02.04.03

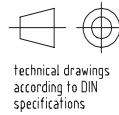
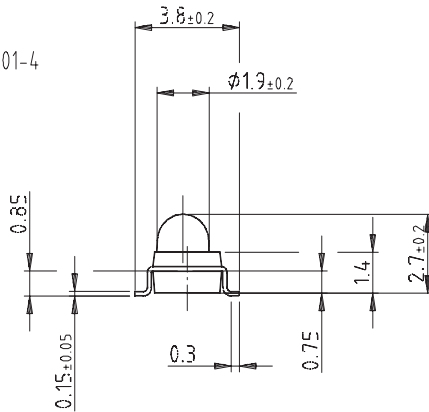

All dimensions in mm

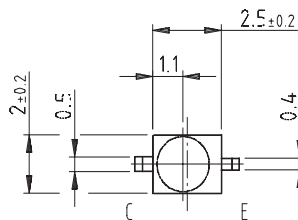

Solder pad proposal

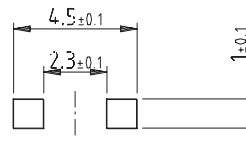

16105

Package Dimensions in mm
TEMT1030

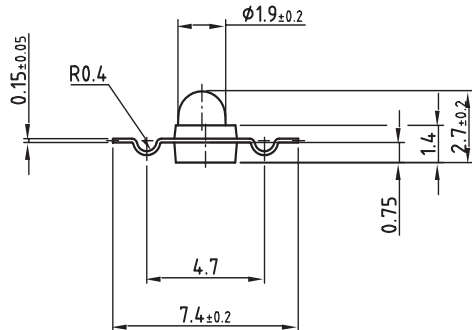

Drawing-No.: 6.544-5329.02-4

Issue: 3; 08.05.03

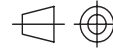

Technical drawings according to DIN specifications

All dimensions in mm

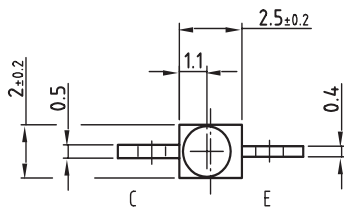

Solder pad proposal

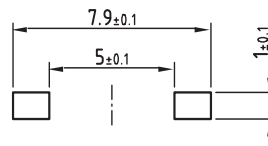

16756

Package Dimensions in mm
TEMT1040

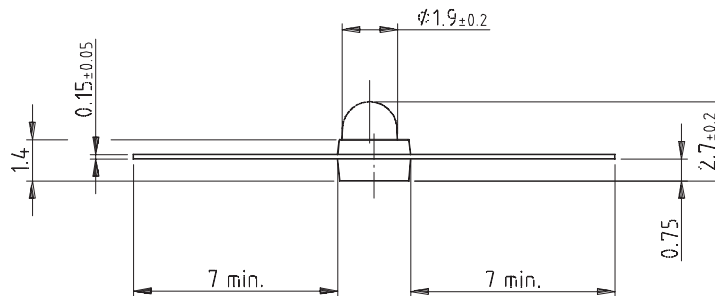

Drawing-No.: 6.544-5339.01-4

Issue: 2; 02.04.03

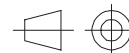

Technical drawings according to DIN specifications

All dimensions in mm

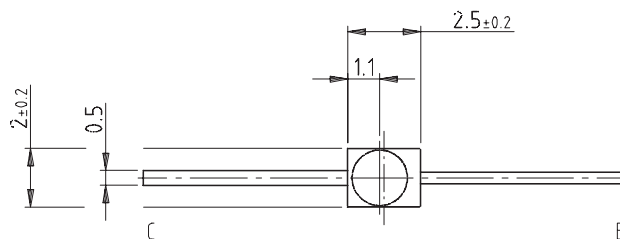

16500

Reel Dimensions

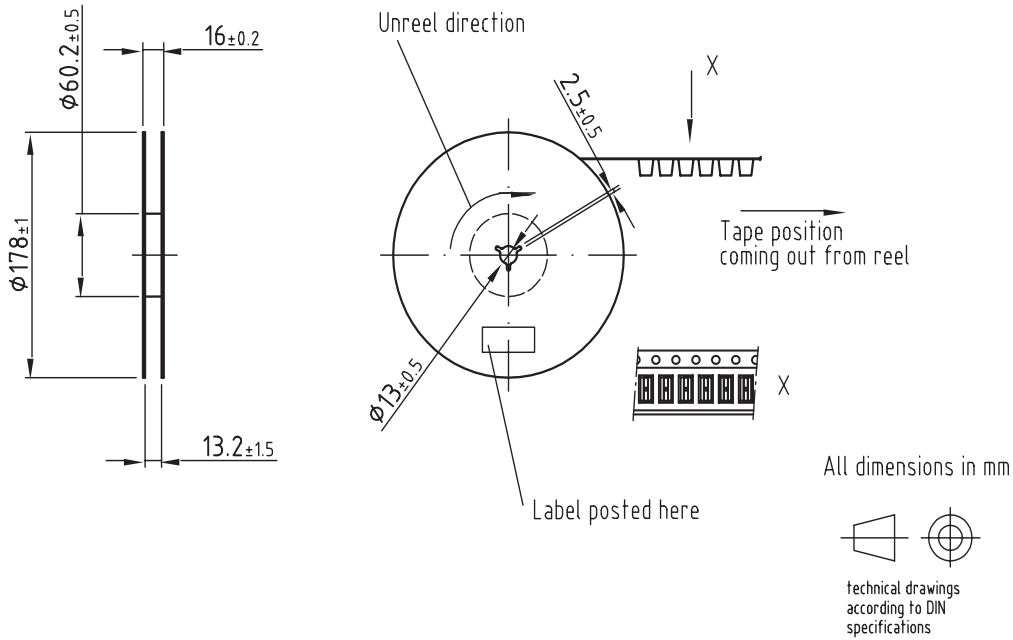

Leader and trailer tape:

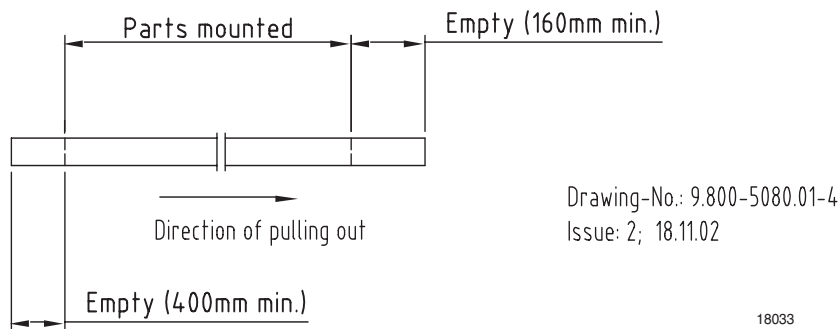

Taping TEMT1000

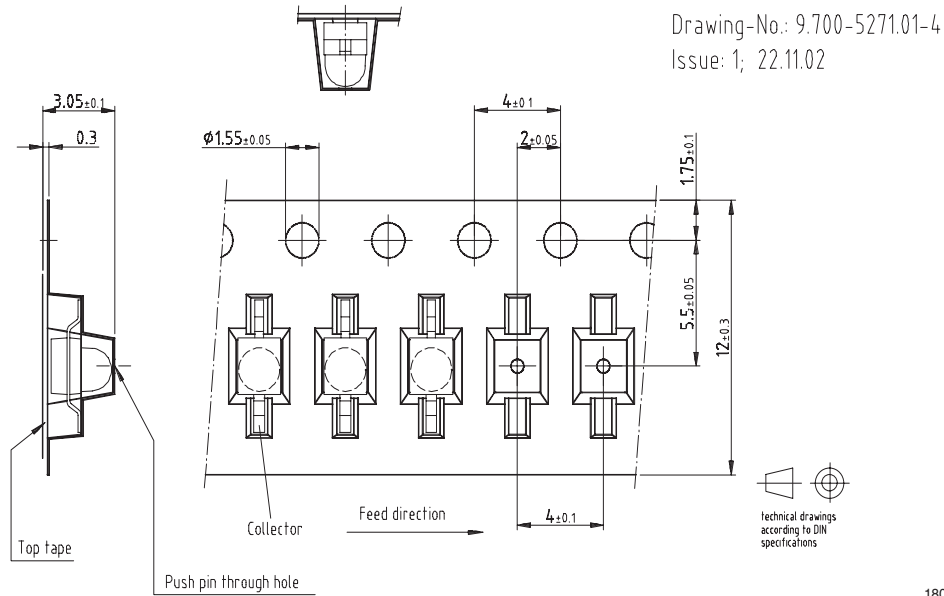

Taping TEMT1020

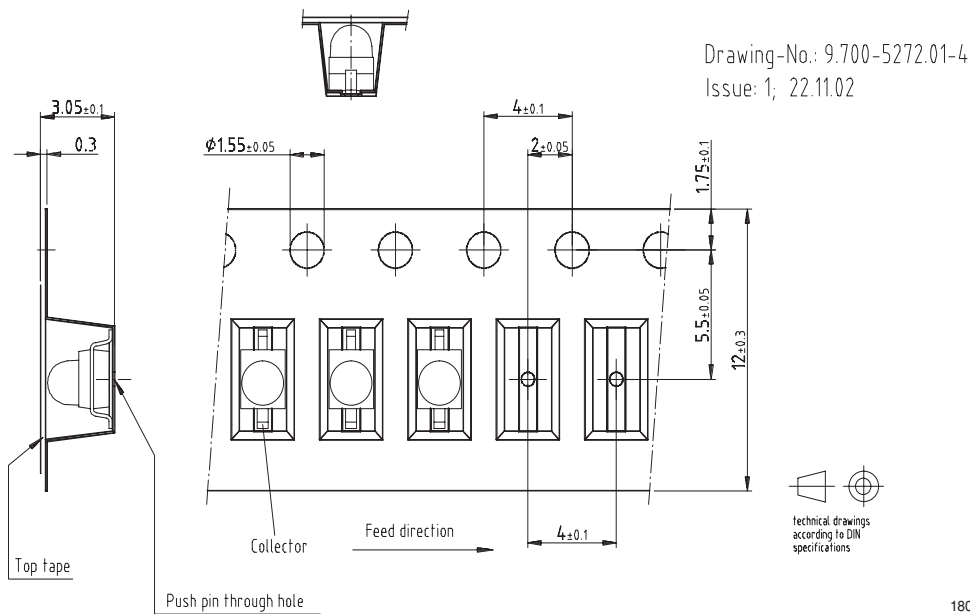

Taping TEMT1030

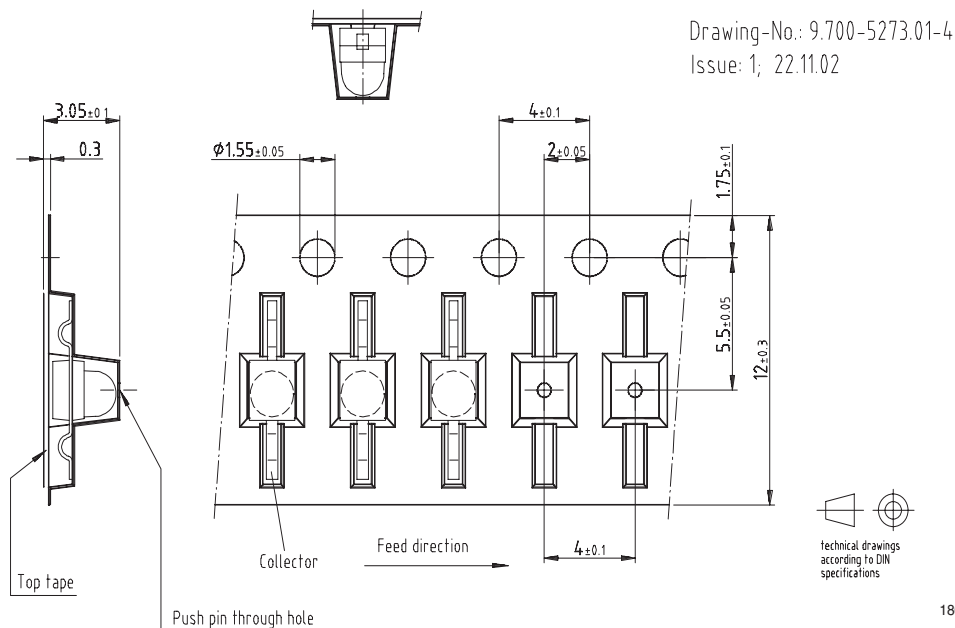

Precautions For Use

1. Over-current-proof

Customer must apply resistors for protection, otherwise slight voltage shift will cause big current change (Burn out will happen).

2. Storage

2.1 Storage temperature and rel. humidity conditions are: 5°C to 35°C, R.H. 60%

2.2 Floor life must not exceed 168 h, acc. to JEDEC level 3, J-STD-020.

Once the package is opened, the products should be used within a week. Otherwise, they should be kept in a damp proof box with desiccant.

Considering tape life, we suggest to use products within one year from production date.

2.3 If opened more than one week in an atmosphere 5°C to 35°C, R.H. 60%, devices should be treated at 60°C ± 5°C for 15 hrs.

2.4 If humidity indicator in the package shows pink color (normal blue), then devices should be treated with the same conditions as 2.3

Reflow Solder Profile

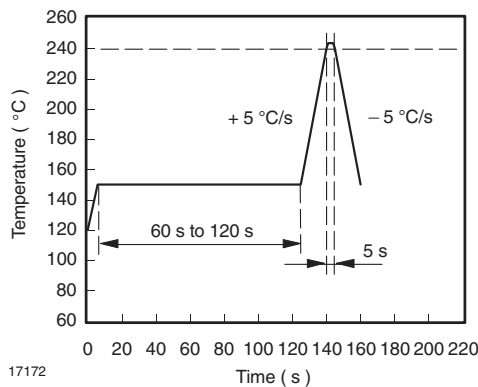



Ozone Depleting Substances Policy Statement

It is the policy of **Vishay Semiconductor GmbH** to

1. Meet all present and future national and international statutory requirements.
2. Regularly and continuously improve the performance of our products, processes, distribution and operating systems with respect to their impact on the health and safety of our employees and the public, as well as their impact on the environment.

It is particular concern to control or eliminate releases of those substances into the atmosphere which are known as ozone depleting substances (ODSs).

The Montreal Protocol (1987) and its London Amendments (1990) intend to severely restrict the use of ODSs and forbid their use within the next ten years. Various national and international initiatives are pressing for an earlier ban on these substances.

Vishay Semiconductor GmbH has been able to use its policy of continuous improvements to eliminate the use of ODSs listed in the following documents.

1. Annex A, B and list of transitional substances of the Montreal Protocol and the London Amendments respectively
2. Class I and II ozone depleting substances in the Clean Air Act Amendments of 1990 by the Environmental Protection Agency (EPA) in the USA
3. Council Decision 88/540/EEC and 91/690/EEC Annex A, B and C (transitional substances) respectively.

Vishay Semiconductor GmbH can certify that our semiconductors are not manufactured with ozone depleting substances and do not contain such substances.

**We reserve the right to make changes to improve technical design
and may do so without further notice.**

Parameters can vary in different applications. All operating parameters must be validated for each customer application by the customer. Should the buyer use Vishay Semiconductors products for any unintended or unauthorized application, the buyer shall indemnify Vishay Semiconductors against all claims, costs, damages, and expenses, arising out of, directly or indirectly, any claim of personal damage, injury or death associated with such unintended or unauthorized use.

Vishay Semiconductor GmbH, P.O.B. 3535, D-74025 Heilbronn, Germany
Telephone: 49 (0)7131 67 2831, Fax number: 49 (0)7131 67 2423

This datasheet has been download from:

www.datasheetcatalog.com

Datasheets for electronics components.