

**Reduced Loop Drop
 3 New Models!**



DMS-30LCDA-4/20 Series

Loop-Powered, 1.8V Drop,
 4-20mA Process Monitors with
 Full-Size LCD-Displays

Order on-line at www.datel.com

Features

- Super-low loop drop: 1.8V typical, 2.0V max.
- Self-powered 2-wire operation; no separate supply required
- Unipolar, Bipolar, Positive, and Inverse Reading Models
- Improved-performance replacement for DMS-30LCD-4/20S
- Subminiature package; Less than 0.90" behind-the-panel depth
- Large, 0.40"/10.2mm high, sunlight-viewable LCD display
- Non-interacting gain (span) and offset (zero) 20-turn potentiometers
- DIP-switch selectable range and decimal points
- Hundreds of different input-current/readout combinations
- Vibration-resistant package; reliable screw-terminal input connections

DATEL's new DMS-30LCDA-4/20 Series' 1.8V nominal loop-drop is the lowest of any comparably priced, 4-20mA input, 3½-digit process monitors with full-size LCD displays. This super-low loop-drop guarantees a maximum burden of no more than 100 Ohms! And because it's loop-powered, all operating power is derived directly from the loop current itself; no separate power source is required! Their floating 2-wire design allows DMS-30LCDA-4/20 Series process monitors to be connected anywhere in the current loop.

All decimal point and range-change selections are made via an eight-position DIP switch which features vibration-resistant, gold-plated contacts—there are no cumbersome jumpers or solder gaps to contend with. Both gain (span) and offset (zero) adjustments are performed using 20-turn, non-interacting potentiometers. Four different models accommodate unipolar, bipolar, positive, and inverse display-reading applications. The DMS-30LCDA-4/20 Series' DIP switch and adjustment potentiometers can accommodate literally hundreds of different input-current/output-reading combinations.

DMS-30LCDA-4/20 Series' subminiature package houses a large, 0.40"/10.2mm, high-contrast LCD display that can be read in virtually all lighting conditions—including full sunlight! The two connections to the external loop are made via a reliable screw-type terminal block. For environmentally demanding applications, an optional panel-mount bezel assembly, featuring screw fasteners and a rubber gasket, provides excellent resistance to dust and moisture. All these outstanding features combine to make the new DMS-30LCDA-4/20 Series ideal for all your 4-20mA process-monitoring instrumentation needs.

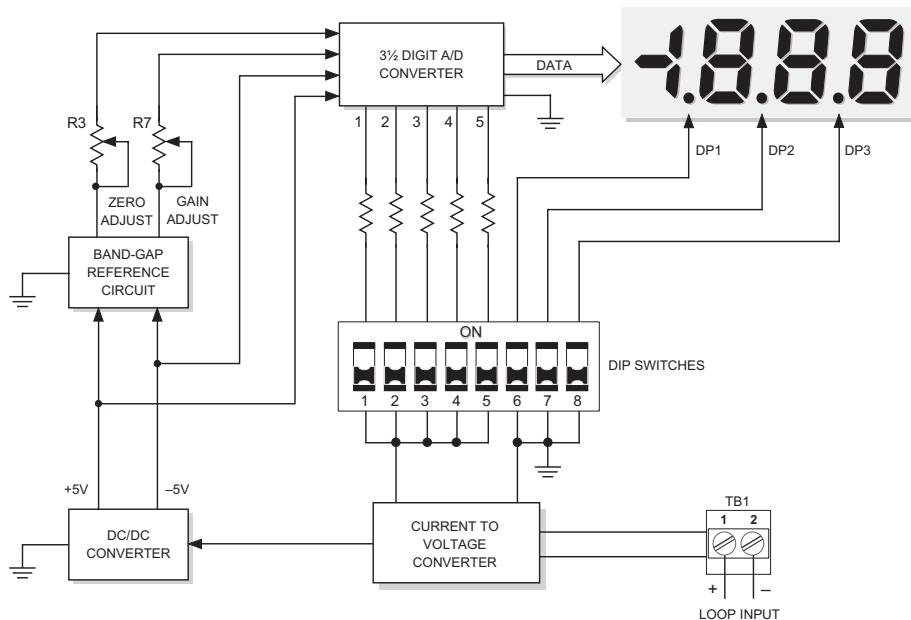

Figure 1. DMS-30LCDA-4/20 Simplified Schematic

Performance/Functional Specifications

Typical at T_A = +25°C, unless otherwise noted.

Current Loop Input	Min.	Typ.	Max.	Units
Full Scale Input Range	+3.8	--	+20.4	mA
Loop Burden	--	80	100	Ω
Voltage Drop	--	1.8	2.0	Volts
Overcurrent Protection	--	--	±40	mA
Performance				
Sampling Rate	2.5 readings per second			
Accuracy (1 minute warm-up)	±0.05%FS ±1 Count			
Temperature Drift (0 to +60°C)	--	±0.15	±0.3	Cnts/°C
Display				
Display Type and Size	3½ digit, 0.4"/10.2mm reflective LCD			
Polarity Indication	"_" for negative readings			
Overrange Indication	"-1___" for negative inputs "1___" for positive inputs			
Physical/Environmental				
Operating Temperature	0	--	+60	°C
Storage Temperature	-20	--	+75	°C
Humidity (Non-condensing)	0	--	85	%
Case Material	Polycarbonate			
Weight	0.75 ounces (21 grams)			

- ① The DMS-30LCDA-4/20 can withstand continuous overcurrents, including those resulting from accidental reverse-polarity connections, up to ±40mA without sustaining any damage.
- ② Because DATEL's DMS Series loop-powered process monitors employ active circuitry to convert the loop current into a voltage, their effective series impedance (loop burden) varies in a manner that maintains the loop voltage drop relatively constant over the full 4-to-20mA current range. Listed burden specification applies at 20mA.
- ③ When looking up DIP-switch settings in the Tables and the desired display readings can be achieved with either of two different settings, using the higher setting number will usually result in less sensitive offset (R3) and span (R7) adjustments. Please keep in mind that the DMS-30LCDA standard meter from which the DMS-30LCDA-4/20 is derived has an accuracy specification of ±2 counts (max.). Thus, it may not always be possible to obtain the exact desired display reading.

Order on-line at www.datel.com

Ordering Information

DMS-30LCDA-4/20S**	Unipolar reading, loop-powered LCD meter
DMS-30LCDA-4/20B	Bipolar reading, loop-powered LCD meter
DMS-30LCDA-4/20P	Positive reading, loop-powered LCD meter
DMS-30LCDA-4/20I	Inverse reading, loop-powered LCD meter
DMS-BZL1	Bezel assembly
DMS-BZL2	Bezel assembly with sealing gasket
DMS-30-CP	Panel cutout punch
DMS-PS4-CM	+24V/0.45A ac/dc power supply module
DMS-PS7-CM	+24V/0.7A ac/dc power supply module

** Replaces obsolete DMS-30LCD-4/20S model
A panel-mount retaining clip is supplied with each model.

Operating and Setup Instructions

Important Instructions for Users of Obsolete DMS-30LCD-4/20S Meters

The new DMS-30LCDA-4/20S unipolar-reading model has provisions to accommodate all the display ranges of the obsolete DMS-30LCD-4/20S. The "Old Display Readings" column in Table 1 is taken directly from the DMS-30LCD-4/20S datasheet. Table 1 is provided as a guide for determining equivalent DMS-30LCDA-4/20S DIP-switch settings in upgrading existing applications.

Applications that had the obsolete DMS-30LCD-4/20S setup for 'bipolar' operation should now use the new DMS-30LCDA-4/20S model configured per Table 1. Bipolar applications are those where a 4mA input displays a negative number, a 12mA input displays "000", and a 20mA input displays a positive number (for example, "-100", "000" and "100").

Applications that had the obsolete DMS-30LCD-4/20S setup for 'unipolar' operation should now use the new DMS-30LCDA-4/20S configured per Table 2. Unipolar applications are those where a 4mA input displays "000" and a 20mA input displays a higher positive

Table 1 DMS-30LCDA-4/20S DIP Switch Settings for DMS-30LCD-4/20S Applications

Old Display Reading	New DMS-30LCDA-4/20S DIP Switch Setting						
	4mA	20mA	SW1	SW2	SW3	SW4	SW5
1. 000 to 100-300			Use Setting in Table 2				
2. 000 to 400-600			Use Setting in Table 2				
3. 000 to 700-1999			Use Setting in Table 2				
4. ±100			On	On	On	On	Off
5. ±200 to ±300			Off	Off	On	Off	Off
6. ±400 to ±600			On	Off	Off	Off	Off
7. ±700 to ±1900			Off	Off	Off	Off	On

DMS-30LCDA-4/20S (Standard Unipolar-Reading)

The DMS-30LCDA-4/20S's span and offset circuitry are optimized to display standard, unipolar readings where a 4mA input always reads "000" and a 20mA input always displays a higher positive number. As shipped, the DMS-30LCDA-4/20S is calibrated to read "000" for a 4mA input and "1800" for a 20mA input. These readings are used for factory test-purposes only. The following worst-case calibration procedure assumes the DMS-30LCDA-4/20S is completely misadjusted, i.e., both potentiometers and the DIP switches are randomly set.

The next example below, while specifically tailored for the "000" and "1800" readings just noted, can also be used as a guide when configuring the DMS-30LCDA-4/20S for other unipolar display readings. When performing DIP-switch settings, be sure the DIP-switch's small actuators are firmly engaged in their fully ON or fully OFF positions.

1. Set R7 (span/gain adjust) and R3 (zero/offset adjust) fully clockwise, roughly 22 turns, and place SW1-SW8 to OFF.
2. Configure the meter per DIP-switch setting #1 in Table 2.
3. Apply a precision 4mA input with proper polarity and adjust R3 until the meter's display reads "000".

- Apply a precision 20mA input and adjust R7 until the display reads "1800". Repeat steps 3 and 4 to make sure the adjustments do not affect one another.
- Select the appropriate decimal point by setting SW6, SW7 or SW8 to ON (DP1, DP2 or DP3 respectively).

NOTE: If a display reading other than "000" to "1000" is desired, refer to DIP-Switch Settings Table 2 for SW1-SW5 settings

Table 2. DMS-30LCDA-4/20S (Standard Unipolar) DIP Switch Settings

Desired Display Reading		SW1	SW2	SW3	SW4	SW5
4mA	20mA					
1. 000 to 1200	to 1999	Off	Off	Off	Off	Off
2. 000 to 600	to 1200	On	Off	Off	Off	Off
3. 000 to 400	to 600	Off	Off	On	Off	Off
4. 000 to 200	to 400	On	On	On	Off	Off
5. 000 to 100	to 200	On	On	On	On	Off

Examples (DMS-30LCDA-4/20S, Unipolar)

- Desired display readings are:

4mA = "0.00"
20mA = "6.00"



Use DIP-switch setting #3 in Table 2 and enable decimal point DP2 via SW7. Apply 4mA and adjust R3 so the display reads "0.00". Apply 20mA and adjust R7 so the display reads "6.00".

- Desired display readings are:

4mA = "000"
20mA = "800"



Use DIP-switch setting #2 in Table 2. Apply 4mA and adjust R3 so the display reads "000". Apply 20mA and adjust R7 so the display reads "800". For these display readings, no decimal points are used. Set SW6, SW7 and SW8 to OFF.

- Desired display readings are:

4mA = ".000"
12mA = ".250"



This example is not as straightforward as the previous two. Notice that 12mA is exactly halfway between 4mA and 20mA. If we assume that the input could go up to 20mA, the display reading would then be: 2 x .250 or ".500". From Table 2 we can now select DIP-switch setting #3 and enable DP1 via SW6. Apply 4mA and adjust R3 so the display reads ".000". Apply 12mA and adjust R7 so the display reads ".250".

DMS-30LCDA-4/20B (Bipolar-Reading)

The DMS-30LCDA-4/20B's zero-offset circuit differs from the unipolar 'S' model described above in that with the 'B' model, a half-scale 12mA input is typically set to display "000". Therefore, all of the of the DIP-switch settings in Table 3 assume a reading of "000" is desired with a half-scale 12mA input. Display readings other than those shown in Table 3 are possible, contact DATEL for more information.

When configuring the DMS-30LCDA-4/20B for the first time, or when selecting a new range, set both R3 and R7 fully clockwise (roughly 22 turns) to their minimum offset/minimum-span positions, respectively. Then select the desired readings from Table 3 and configure DIP-switches SW1, SW2, and SW3 accordingly. Please note, positions SW4 and SW5 are not used in bipolar 'B' models.

The procedure below illustrates how to calibrate the DMS-30LCDA-4/20B to its factory-calibrated readings of "-1000" with a 4mA input and "1000" with a 20mA input. When performing DIP-switch settings, be sure the DIP-switch's small actuators are firmly engaged in their fully ON or fully OFF positions.

- Set both R3 and R7 fully clockwise.
- Select DIP-switch setting #1 from Table 3.
- Apply a precision 12mA input and adjust R3 until the meter's display reads "000".
- Apply a precision 20mA input and adjust R7 until the meter's display reads "1000".
- Apply a precision 4mA input and the display should read "-1000". Repeat steps 3 and 4 to make sure the two adjustments did not affect

Table 3. DMS-30LCDA-4/20B (Bipolar) DIP Switch Settings

Desired Display Reading			SW1	SW2	SW3	SW4	SW5
4mA	12mA	20mA					
1. -600 to -1000	000	600 to 1000	Off	Off	Off	NA	NA
2. -350 to -650	000	350 to 650	On	Off	Off	NA	NA
3. -250 to -400	000	250 to 400	Off	On	Off	NA	NA
4. -150 to -250	000	150 to 250	Off	Off	On	NA	NA
5. -100 to -150	000	100 to 150	On	On	On	NA	NA

Examples (DMS-30LCDA-4/20B, Bipolar)

- Desired display readings are:

4mA = "-1.00"
20mA = "1.00"



Use DIP-switch setting #5 in Table 3 and enable decimal point DP2 via SW7. Apply 12mA and adjust R3 so the display reads "0.00". Apply 20mA and adjust R7 so the display reads "1.00". Apply 4mA and verify that the display reads "-1.00", readjust R3 and R7 if necessary.

- Desired display readings are:

4mA = "-450"
20mA = "450"



Use DIP-switch setting #2 in Table 3. Apply 12mA and adjust R3 so the display reads "000". Apply 20mA and adjust R7 so the display reads "450". Apply 4mA and verify that the display reads "-450". Repeat adjustment procedure if necessary. For these display readings, no decimal points are used. Set SW6, SW7 and SW8 to OFF.

3. Desired display readings are:

4mA = "-650"
20mA = "650"

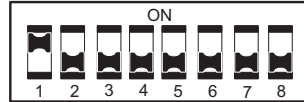

Notice that these readings can be obtained using either DIP-switch setting #1 or DIP-switch setting #2 in Table 3. In situations like this where DIP-switch settings overlap, less-sensitive R3/R7 adjustments can be achieved if the higher DIP-setting # is selected (setting #2 in this example). Apply 12mA and adjust R3 so the display reads "000". Apply 20mA and adjust R7 so the display reads "650". Apply 4mA and verify that the display reads "-650". Repeat adjustments if necessary.

DMS-30LCDA-4/20P (Positive-Reading)

The DMS-30LCDA-4/20P's zero-offset circuit is optimized to produce positive readings at both 4mA and 20mA input levels. As shown in Table 4's first three columns, a 4mA input can be adjusted (using R3, Zero/Offset Adjust) to display any positive reading between "000" and "800". The corresponding 20mA-input reading is then added to the 4mA offset as a differential whose magnitude is varied by adjusting R7 (Gain/Span Adjust).

The 'Differential Range' column in Table 4 lists the nominal differential display-readings which can be obtained with R7 at, or very close to, its full-clockwise, minimum span position. The 'Differential Range' column can be used as a guide when configuring the meter for the majority of user applications. Higher differential ranges are obtainable; however, the use of higher differential readings results in correspondingly-lower positive readings with 4mA inputs, that is, R3's clockwise adjustment-range is reduced. Example #3 below illustrates this point. Contact DATEL if there is any doubt as to whether or not the DMS-30LCDA-4/20P can be configured for your display-reading requirements.

The first step when initially configuring the DMS-30LCDA-4/20P, or when selecting a new range, is to set R3 fully counterclockwise and R7 fully clockwise (roughly 22 turns each) to their minimum offset and minimum span positions, respectively.

The next step is to calculate the differential display-reading; this is accomplished by subtracting the desired 4mA display reading from the desired 20mA display reading, disregarding decimal points. Then, using the calculated differential display-reading to select the appropriate DIP-switch setting # from Table 4, configure DIP-switches SW1, SW2, and SW3 accordingly. Please note, positions SW4 and SW5 are not used in positive reading 'P' models. Also, make certain that the DIP-switch's small actuators are firmly engaged in their fully ON or fully OFF positions.

The example below describes how to calibrate the meter for an application which the DMS-30LCDA-4/20P easily accommodates: displaying the output of a 4-20mA transmitter, that is, "04.0" with a 4mA input and "20.0" with a 20mA input.

1. Set R3 fully counterclockwise (minimum offset position) and R7 fully clockwise (minimum differential span position), roughly 22 turns.
2. Subtract 040 from 200 to yield a differential-reading value of 160; use this value to select DIP-switch setting #5 in Table 4. Enable decimal

point DP3 by placing SW8 to the ON position.

3. Set the transmitter's output to 4.0mA and carefully adjust R3 clockwise until the meter's display reads "000".
4. Set the transmitter's output to 20.0mA and adjust R7 counterclockwise until the meter's display reads "16.0".
5. Set the transmitter back to 4.0mA and slowly adjust R3 clockwise until the display reads "04.0". Reapply 20.0mA and the display should now read "20.0". Repeat steps 3, 4, and 5 to make sure the adjustments did not affect one another.

Table 4. DMS-30LCDA-4/20P (Positive Reading)
DIP Switch Settings

Desired Display Readings								
Diff. Range	4mA	20mA	SW1	SW2	SW3	SW4	SW5	
1. 800 to 1400	900	1700	Off	Off	Off	NA	NA	
2. 500 to 800	850	1350	On	Off	Off	NA	NA	
3. 350 to 500	800	1150	Off	On	Off	NA	NA	
4. 250 to 350	750	1000	Off	Off	On	NA	NA	
5. 150 to 250	750	900	On	On	On	NA	NA	

Examples (DMS-30LCDA-4/20P, Positive Reading)

1. Desired display readings are:

4mA = "650"
20mA = "950"



Use DIP-switch setting #4 in Table 4 since subtracting 650 from 950 yields a differential value of 300. Apply 4mA and adjust R3 until the display reads "000". Apply 20mA and adjust R7 until the display reads "300" (the differential value previously calculated). Apply 4mA and adjust R3 until the display reads "650". Apply 20mA and verify that the display reads "950".

2. Desired display readings are:

4mA = "4.00"
20mA = "19.99"



This example illustrates the DMS-30LCDA-4/20P's capability to display higher differential readings than those indicated in Table 4. This example also illustrates how the DMS-30LCDA-4/20P can be used to display the output levels of a 4-20mA transmitter with higher precision (0.01mA versus 0.1mA) than the example previously described.

Subtracting 400 from 1999 yields a differential of 1599, a value not listed in Table 4. However, use DIP-switch setting #1 in Table 4 since this setting has the highest overall offset/span adjustment capabilities. Enable DP2 via SW7, then apply 4mA and adjust R3 so the display reads "0.00". Apply 20mA and adjust R7 so the display reads "15.99". Apply 4mA and adjust R3 until the display reads "4.00". Apply 20mA and check to see that the display reads "19.99" or just overranges ("1—"). Repeat adjustment procedure if necessary.

DMS-30LCDA-4/20I (Inverse Reading)

The DMS-30LCDA-4/20I is designed to accommodate applications where an **increasing** loop current produces a **decreasing** display reading. That is, as the loop current is increased from 4mA to 20mA, the display will read a user determined full-scale positive number at 4mA and then decrease to "000" at 20mA. The '4/20I' model is essentially a '-4/20S' model operating in reverse. Table 5 and the two examples that follow describe the operation of this model in greater detail.

The first step when configuring the DMS-30LCDA-4/20I for the first time, or when changing to a different range, is to set both R3 and R7 to their full clockwise positions, roughly 22 turns. Next, using the desired display readings, select the appropriate DIP-switch setting number from Table 5.

Table 5. DMS-30LCDA-4/20I (Inverse Reading) DIP Switch Settings

Desired Display Reading		SW1	SW2	SW3	SW4	SW5
4mA	20mA					
1. 1999 to 1300	000	Off	Off	Off	Off	NA
2. 1300 to 850	000	On	Off	Off	Off	NA
3. 850 to 550	000	Off	On	Off	Off	NA
4. 550 to 350	000	Off	Off	On	Off	NA
5. 350 to 200	000	On	On	On	Off	NA
6. 200 to 130	000	On	On	On	On	NA

Examples (DMS-30LCDA-4/20I, Inverse Reading)

1. Desired display readings are:

4mA = "6.00"

20mA = "0.00"



Use DIP-switch setting #3 in Table 5 and enable decimal point DP2 via SW7. Apply 20mA and adjust R3 so the display reads "0.00". Apply 4mA and adjust R7 so the display reads "6.00".

2. Desired display readings are:

4mA = "800"

20mA = "000"



Use DIP-switch setting #2 in Table 5. Apply 20mA and adjust R3 so the display reads "000". Apply 4mA and adjust R7 so the display reads "800". For these display readings, no decimal points are used. Set SW6, SW7 and SW8 to OFF.

Table 6. Decimal Point Selections (All Models)

To turn on a decimal point, place its respective DIP switch to the fully ON position.		
SW6	SW7	SW8
DP1	DP2	DP3

Mechanical Specifications

MECHANICAL DIMENSIONS: Inches (mm)

TOLERANCES: 2 PL DEC ±0.02 (±0.51)
3 PL DEC ±0.010 (±0.254)

WIRE SIZE: 18 to 26 AWG
(Solid or stranded)

STRIPPING LENGTH: 0.20" (5.08mm)

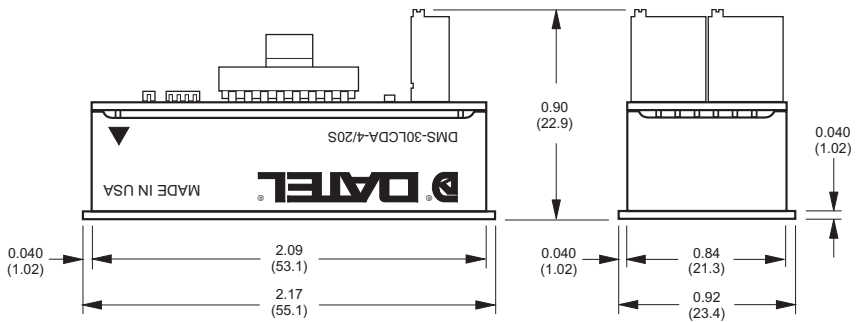

Back View

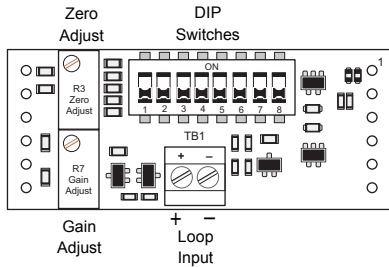

Front View

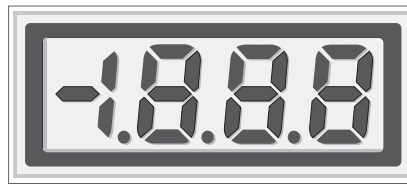

DP1 (SW6) DP2 (SW7) DP3 (SW8)

OPTIONAL BEZEL (DMS-BZL1 and DMS-BZL2)

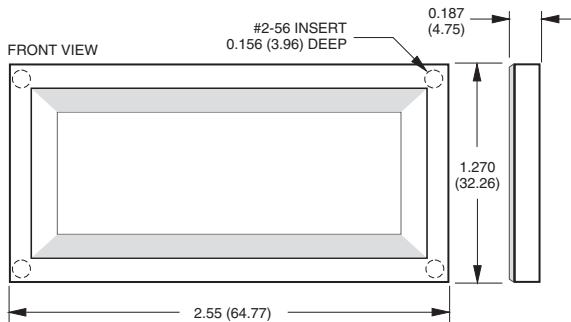

RECOMMENDED DRILL AND PANEL CUTOUT DIMENSIONS

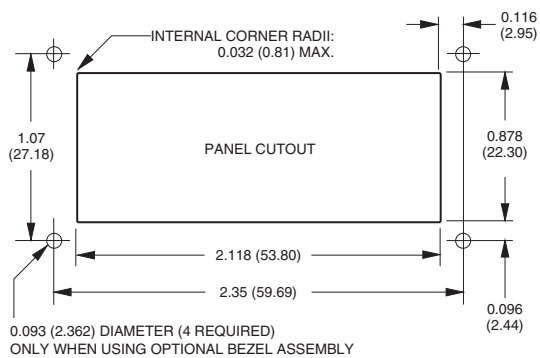

BEZEL INSTALLATION

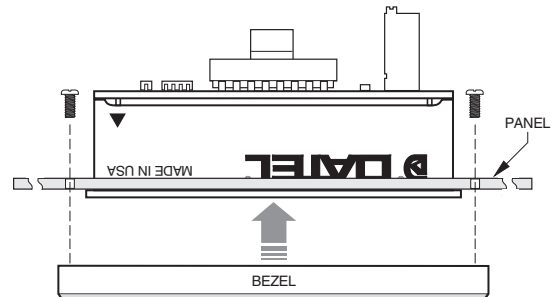

RETAINING CLIP INSTALLATION

