

GENERAL TOLERANCE LIST

SPECIFICATION	TOLERANCE
1~3	±0.20
3~6	±0.24
6~10	±0.29
10~18	±0.35
18~30	±0.42
30~50	±0.50
50~80	±0.60
80~120	±0.70
120~180	±0.80
180~250	±0.92
250~400	±1.05

SYM	DATE	REVISION RECORD	REV. NO.	VER	APPROVED
^				1.0	

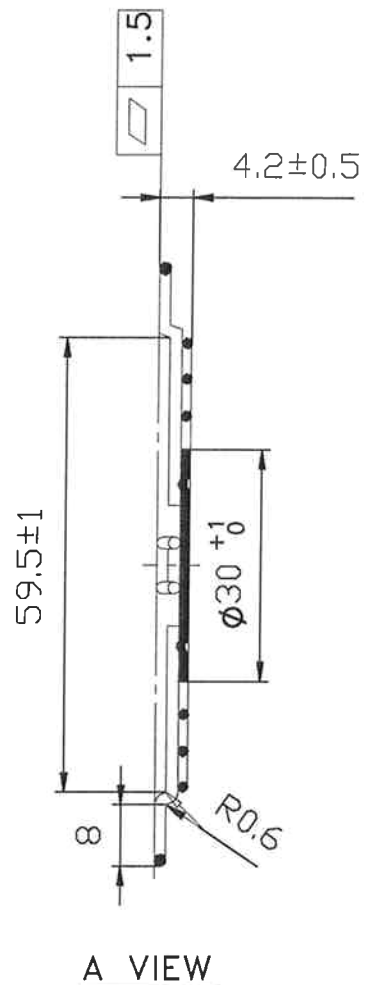
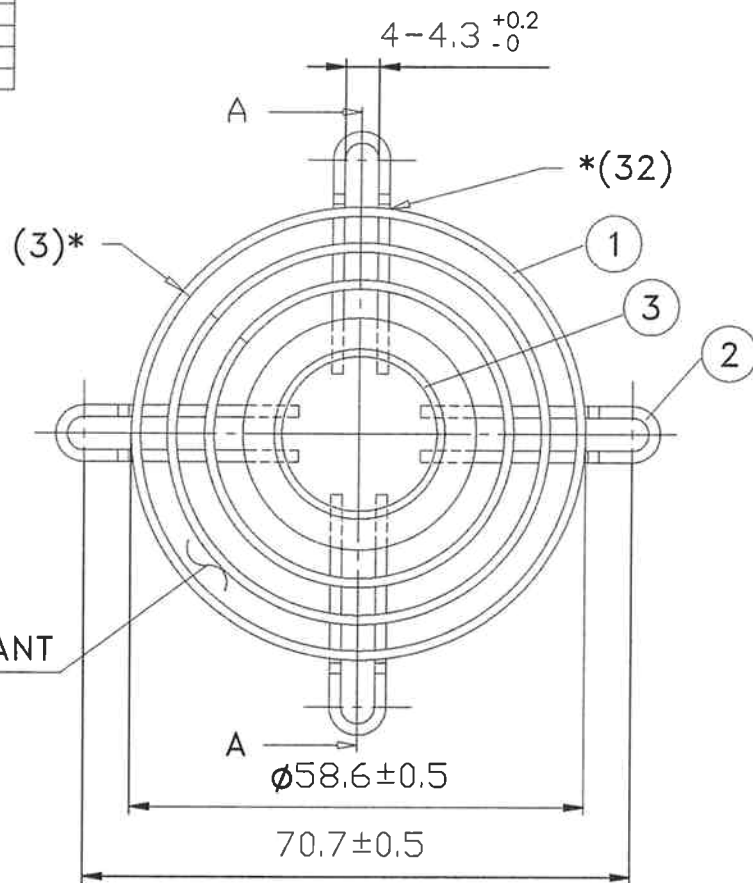

NOTES:

- 1.MATERIAL:SAE1008(OR EQUIVALENCE) BRIGHT BASIC WIRE.
- 2.FINISH:BRIGHT NICKEL CHROME PLATING. (TRIVALENCE CHROME)
3. 0.30±0.05 DEPTH OF SERRATIONS ON WIRE.
- 4.WELD JOINTS TO WITHSTAND 70 LBS PULL FORCE.
- 5.RING:φ1.2; RIB:φ1.5;DISC:T=1.0.
- 6.UNIT:mm.

EQUIDISTANT

3	-005	DISC	1
2	-004	RIB	4
1	-001~-003	RING	3
NO.	PART NO.	TITLE	PCS

APPROVED	CHECKED	DESIGNED	DRAWN	1st ANGLE PROJECTION	MAT	SAE1008	TITLE	FAN GUARD
				SCALE /	FINISH	Ni-Cr	PART NO.	08628
				1th DATE	Qualtek Electronics Ltd.			
				NOV.26,98'				