

**Farnell Item No. : 899 938**

**Ziehl-ebm Order Code : Q2G030-FB01-01**

**Item Description : 12V dc Crossflow fan, 365 mm long**

**Dimensions :-**

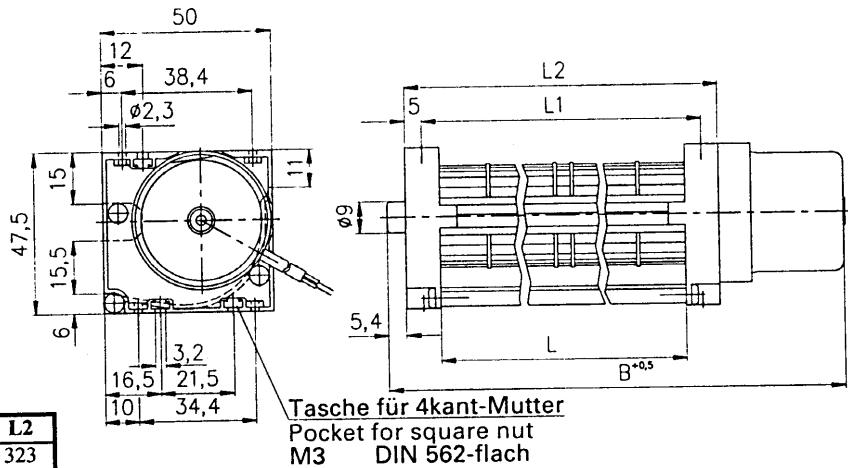

All dimensions are in mm.

Dimensions	B	L	L1	L2
mm	365	303	313	323

**Technical Data :-**

Supply = 12 Vdc.

Farnell Item No.	Ziehl-ebm Order code	Voltage range (Vdc)	Air Volume (m <sup>3</sup> /h)	Speed (rpm)	Power input (W)	Current (A)	Starting Current (A)	Noise level (dBA)	Max. ambient (°C)	Approx. Weight (kg)
899 938	Q2G030-FB01-01	8 - 14	130	3900	8.5	0.71	1.8	49	60	0.4

The noise level quoted is Sound Pressure measured at 1 metre from the fan in an echo-free chamber.

**General Information :-**

**Housing :** Aluminium with plastic end brackets.

**Impeller :** Aluminium.

**Motor :** 12Vdc External rotor Brushless direct current motor.

Class B insulation to EN60335-1.

Enclosure Protection IP21.

Polarity and Lock rotor protection.

Lead length 300 mm from stator flange.

**Connection :** Red = +, Blue = -

**Bearings :** Maintenance free shielded ball bearings.

**Standards :** Complies with EN60335-1.