

HDSM-441W/443W

0.39inch (10.0mm)

Dual digit surface mount LED display



Data Sheet

Description

This is 0.39" (10.0mm) height dual digit display. This device utilizes white ChipLED. This device comes with top surface gray and white segments.

White HDSM-	Description
441W	Common Anode, Right Hand Decimal
443W	Common Cathode, Right Hand Decimal

Features

- 0.39" digit height
- Low current operation
- Excellent characters appearance
- Available in CA and CC
- 500 pieces per reel
- Moisture Sensitivity Level: Level 3
- RoHS compliant

Package Dimensions

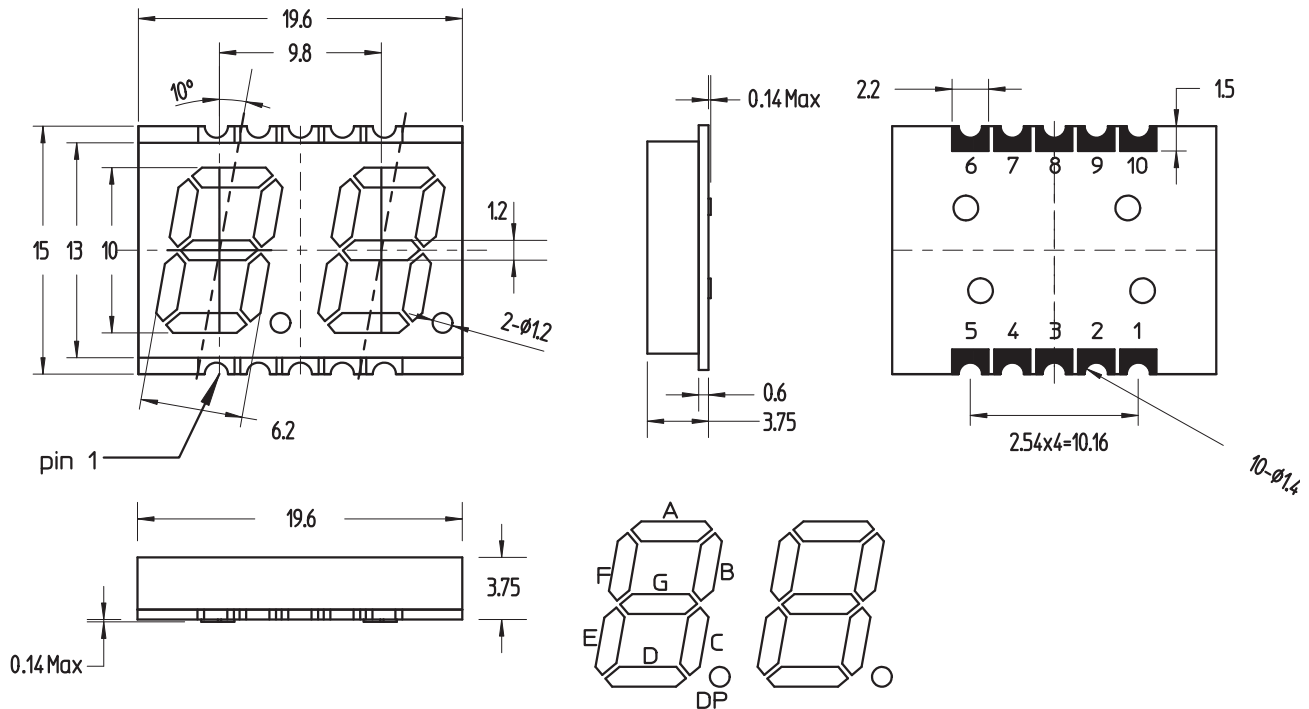

Note:

1. All dimensions are in millimeters.
2. Tolerance are +/- 0.25mm unless otherwise specified.

CAUTION: LEDs are Class 1A ESD sensitive per JESD22-A114C.01. Please observe appropriate precautions during handling and processing.

Pin Connection (Common Anode)

Pin No.	Connection
1	CATHODE G
2	CATHODE DP
3	CATHODE A
4	CATHODE F
5	COMMON ANODE DIG2
6	CATHODE D
7	CATHODE E
8	CATHODE C
9	CATHODE B
10	COMMON ANODE DIG1

Pin Connection (Common Cathode)

Pin No.	Connection
1	ANODE G
2	ANODE DP
3	ANODE A
4	ANODE F
5	COMMON CATHODE DIG2
6	ANODE D
7	ANODE E
8	ANODE C
9	ANODE B
10	COMMON CATHODE DIG1

Internal Circuit Diagram (Common Anode)

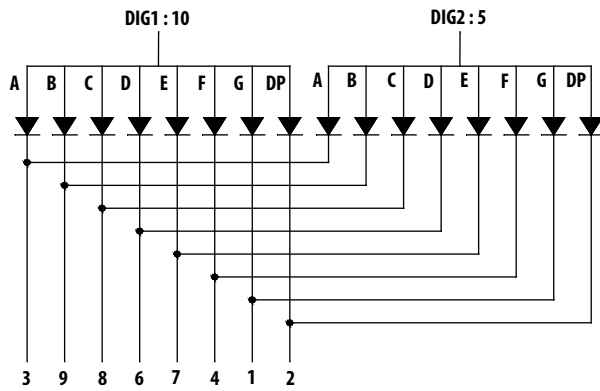

Internal Circuit Diagram (Common Cathode)

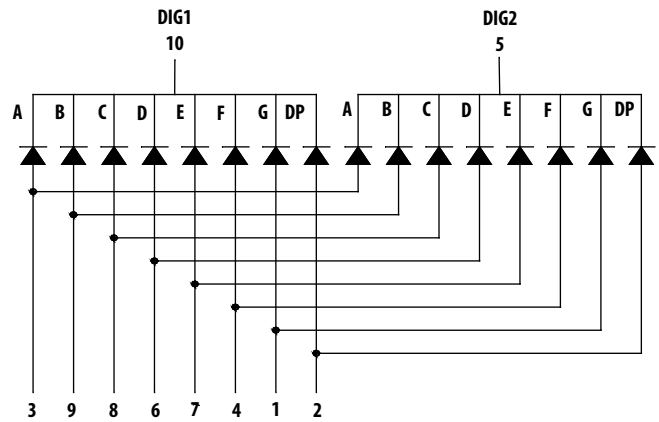

Absolute Maximum Ratings @ T_A=25°C

Parameter	White	Unit
Power Dissipation Per Segment	39	mW
Peak Forward Current Per Segment (1/10 Duty Cycle, 0.1ms pulse width)	80	mA
Continuous Forward Current Per Segment Derating Linearly From 25°C Per Segment	25 0.25	mA mA/°C
Reverse Voltage Per Segment	5	V
Operating Temperature Range		-40°C to +105°C
Storage Temperature Range		-40°C to +105°C

Electrical / Optical Characteristics @ T_A=25°C**White**

Parameter	Symbol	Min.	Typ.	Max.	Unit	Test Condition
Average Luminous Intensity	I _V	24	40	–	mcd	I _F = 5 mA
Chromaticity Coordinates	(X,Y)		Refer to Figure 1			I _F = 5 mA
Forward Voltage, Per Segment	V _F	–	2.95	3.8	V	I _F = 5 mA
Reverse Current, Per Segment	I _R	–	–	100	μA	V _R = 5 V
Luminous Intensity Matching Ratio	I _{V-m}	–	–	2:1	–	I _F = 5 mA

Typical Electrical / Optical characteristic Curves @ $T_A=25^\circ\text{C}$

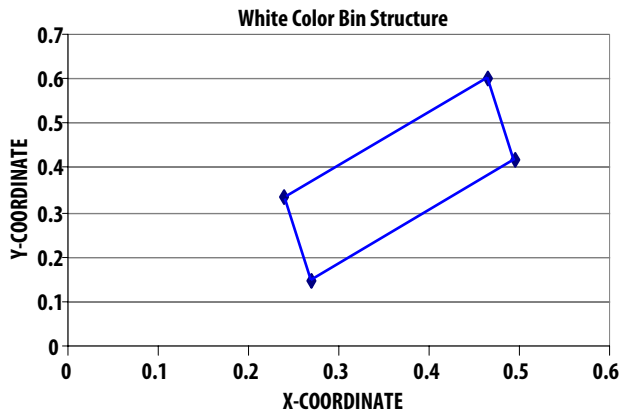

Chromaticity Coordinates				
X	0.24	0.495	0.269	0.465
Y	0.332	0.418	0.147	0.602

Figure 1. Color bin limit (CIE 1931 Chromaticity Diagram)
[Tolerance: +/-0.02]

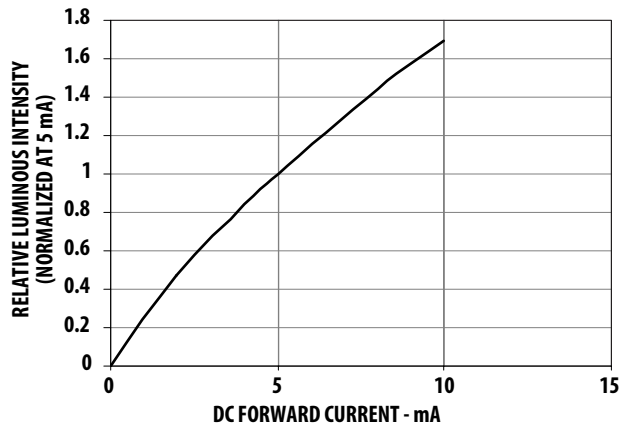

Figure 2. Relative luminous intensity versus forward current

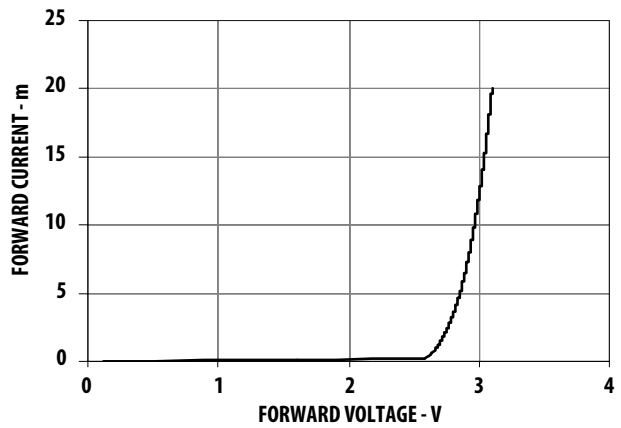

Figure 3. Forward current versus forward voltage

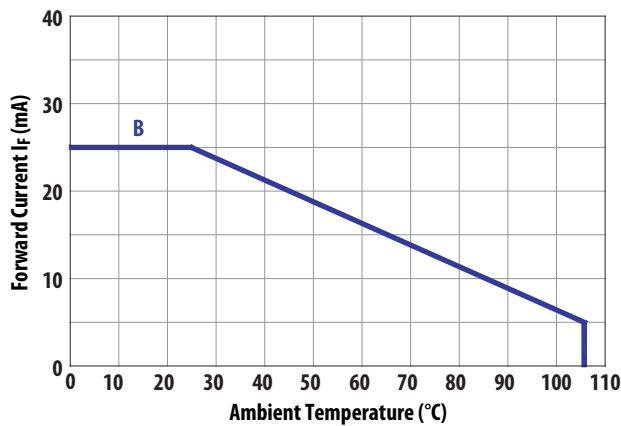
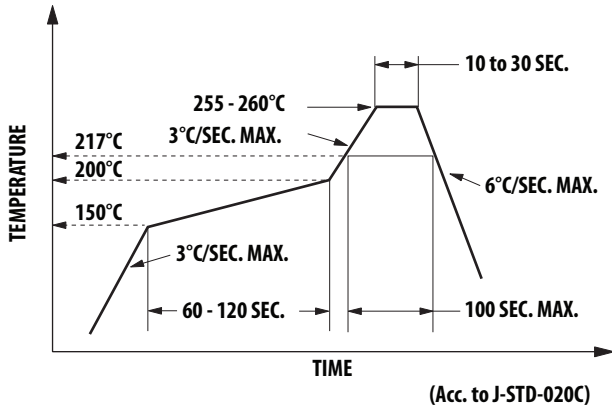

Figure 4. Allowable DC Current Versus Ambient Temperature

SMT Soldering Profile



Pb free reflow soldering Profile

Notes:
 Number of reflow process shall be less than 2 times and cooling process to normal temperature is required between the first and than second soldering process.

Recommended Soldering Pattern (unit: mm)

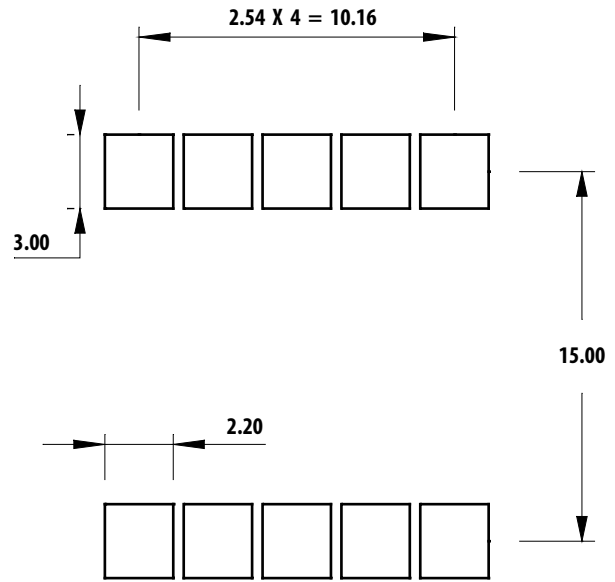

Tape Specification (unit: mm)

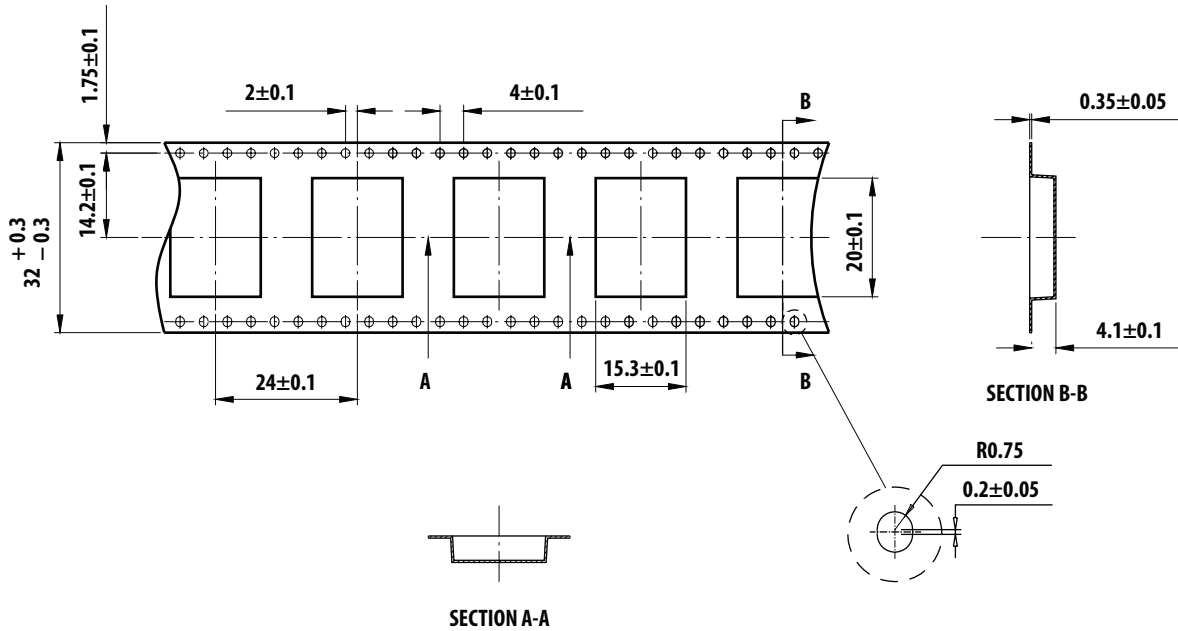

For product information and a complete list of distributors, please go to our web site: www.avagotech.com

Avago, Avago Technologies, and the A logo are trademarks of Avago Technologies in the United States and other countries.
 Data subject to change. Copyright © 2005-2008 Avago Technologies. All rights reserved.
 AV02-1643EN - December 24, 2008

