

Magnetic Pattern Recognition Sensors



Standard Compact Type

■ Features (BS05C Series)

1. High sensitivity and excellent gap characteristics.
2. Output voltage is independent of scanning speed.
3. Compact size and light weight make them ideal for downsizing.
4. Longer product life is given to BS05C series with a specially hard metal cover.
5. BS05C1HGCA has superior noise immunity against induced noise originated from motors and transformers.

■ Applications

1. Bank note validator.
2. Magnetic ink document reader.
3. Magnetic card reader.
4. Magnetic gear detector.

■ Features (BS05N Series)

1. High sensitivity and excellent gap characteristics.
2. Output voltage is independent of scanning speed.
3. Compact size and light weight make them ideal for downsizing.
4. Low cost is achieved by BS05N1 series due to its simple structure.
5. BS05N1HGAA has superior noise immunity against induced noise originated from motors and transformers.
6. BS05N1NFAA can decrease the influences when a detection body has a location deviation because detection width is wide with 6mm.

■ Applications

1. Bank note validator.
2. Magnetic ink document reader.
3. Magnetic card reader.
4. Magnetic gear detector.

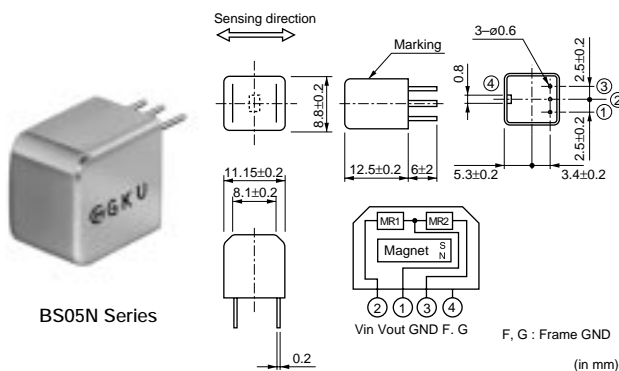
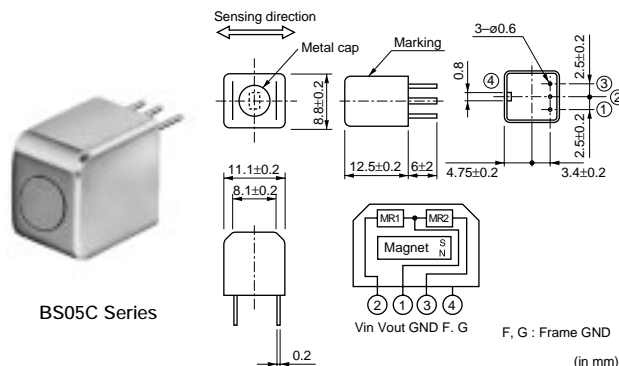

Part Number	Supply Voltage (V)	Total Resistance (k ohm)	Output Voltage (mVrms)	Test Method	Detection Width (mm)	Resolution (mm)	Operating Temperature Range (°C)
BS05C1HFAA	5	0.5 to 6	400 min.	Test Method A	3	0.75	-20 to 60
BS05C1HGCA	5	0.5 to 6	235 to 405	Test Method A	3	0.75	-20 to 60
BS05N1HFAA	5	0.5 to 6	400 min.	Test Method A	3	0.75	-20 to 60
BS05N1HGAA	5	0.5 to 6	235 to 405	Test Method A	3	0.75	-20 to 60
BS05N1NFAA	5	0.6 to 6	330 min.	Test Method B	6	0.75	-20 to 60

1

Test Method A

1. Amplifier's gain is set to 1,100 at the frequency of 60 Hz.
Fig.1 shows the detail of amplifier.
2. DUT is set in the test fixture as shown in Fig.2.
3. AC current of 100mA_{rms} is applied to the copper wire.
4. Amplifier's output voltage is read with DMM while DUT is slowly moved along the guide rail.

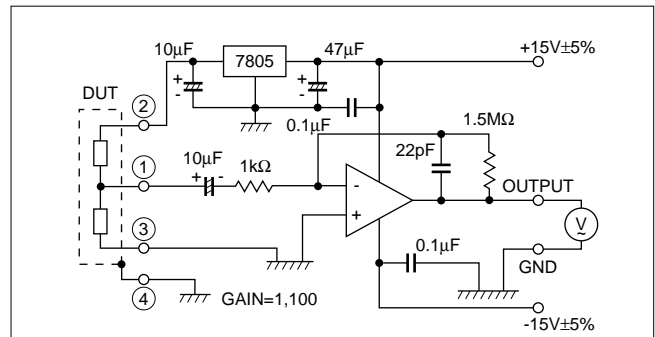

Fig.1 Amplifier for Output Voltage Measurement

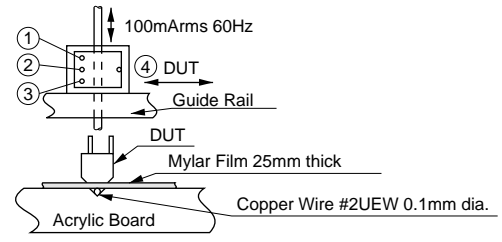

Fig.2 Test Fixture for Output Voltage Measurement

Test Method B

1. Amplifier's gain is set to 1,100 at the frequency of 60 Hz.
Fig.1 shows the detail of amplifier.
2. DUT is set in the test fixture as shown in Fig.2.
3. AC current of 100mA_{rms} is applied to the copper wire.
4. Amplifier's output voltage is read with DMM while DUT is slowly moved along the guide rail.

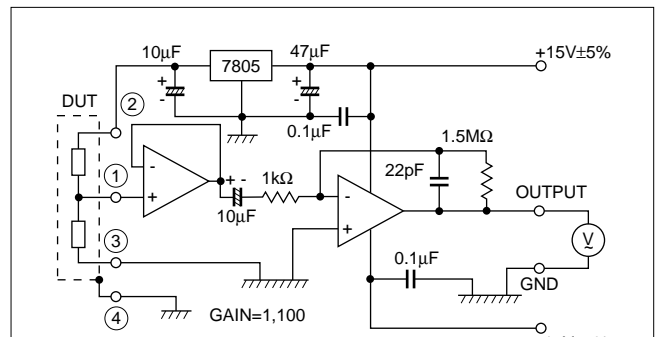

Fig.1 Amplifier for Output Voltage Measurement

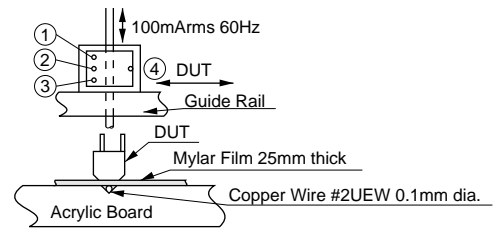

Fig.2 Test Fixture for Output Voltage Measurement

Magnetic Pattern Recognition Sensors



Wide Sensing Element Type

■ Features (BS05W Series)

1. Wide MR element covering extensive area allows large tolerance for scanning and can accept variety of bank note.
2. Long product life achieved by an extremely hard metal cover, is ideal for use in high speed ATM and bank note counters.
3. High sensitivity and excellent gap characteristics.
4. Output voltage is independent of scanning speed.
5. BS05W1KFAB is ideal for use in high-speed process machine such as ATM and bank note counters because an extremely hard metal cover is used.

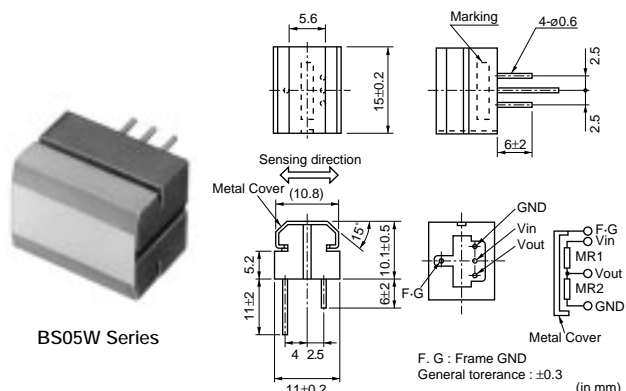

■ Applications

1. Bank note validator.
2. Magnetic ink document reader.

Part Number	Supply Voltage (V)	Total Resistance (k ohm)	Output Voltage (mVp-p)	Test Method	Detection Width (mm)	Resolution (mm)	Operating Temperature Range (°C)
BS05W1KFAA	5	1 to 15	0.3 to 0.8	Test Method C	10	0.75	-20 to 60
BS05W1KFAB	5	1 to 15	0.3 to 0.8	Test Method C	10	0.75	-20 to 60

■ Test Method C

1. Output voltage is measured by using the magnetic pattern card. The magnetic pattern card has same magnetic density of 1000 letter on 1000yen bank note.
2. Drive the magnetic pattern card and record output voltage Vp-p with X-Y recorder.

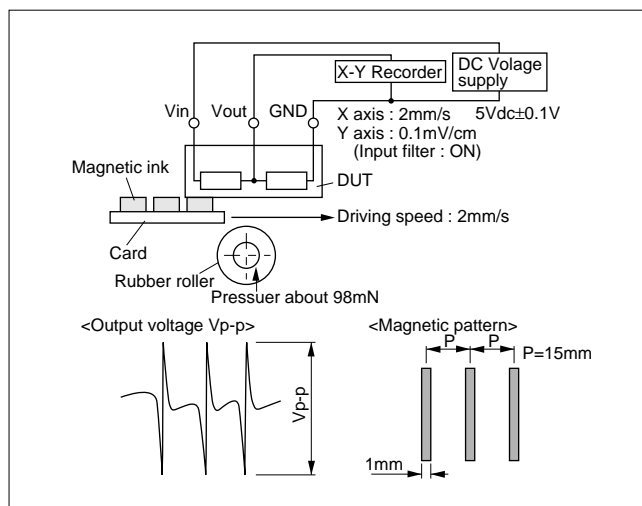

Magnetic Pattern Recognition Sensors



Multi-channel Type

■ Features

1. High sensitivity and excellent gap characteristics.
2. Output voltage is independent of scanning speed.
3. Compact size and light weight make them ideal for downsizing.
4. Simple and quick mounting is possible due to one single holder for multiple MR elements.

■ Applications

1. Bank note validator
2. Pattern recognition of magnetic ink printing.
3. High speed bank note counter.

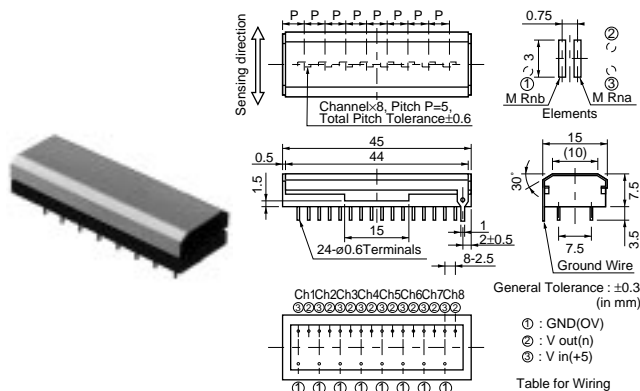

Part Number	Supply Voltage (V)	Total Resistance (k ohm)	Output Voltage (mVrms)	Test Method	Detection Width (mm)	Resolution (mm)	Operating Temperature Range (°C)
BS05M1HFAL	5	0.5 to 6	150 min.	Test Method D	3	0.75	0 to 50

■ Test Method D

1. Amplifier's gain is set to 70dB at the frequency of 500Hz. Fig.1 shows the detail of amplifier.
2. DUT is set in the test fixture as shown Fig.2.
3. AC current of 100mArms is applied to the copper wire.
4. Amplifier's output voltage is read with DMM while DUT is slowly moved along the guide rail.

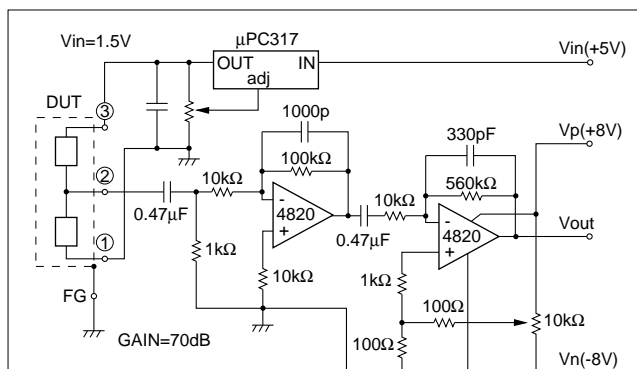

Fig.1 Amplifier for Output Voltage Measurement

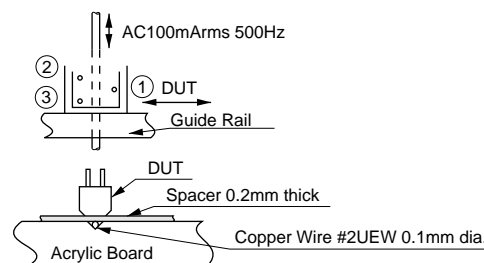

Fig.2 Test Fixture for Output Voltage Measurement

⚠Caution/Notice

■ ⚠Caution (Handling)

1. This sensor generates very strong suction because this product contains a permanent magnet. Be careful of handling the sensor not to apply mechanical shock.
2. Do not approach this product to the magnetic recording media such as magnetic tape or floppy disk. Magnetic recording could be damaged.
3. Do not approach this product to the person who is with an electronic medical device. It is very dangerous by miss operation of an electronic medical device.

■ Notice (Storage and Operating Condition)

1. Please avoid the water, chemical solvent or oil.
2. Please avoid the corrosive gas (Chlorine gas, Hydrogen sulfide gas, Nitric oxide gas, Ammonia gas, Nitric oxide gas, etc.).
3. Please avoid the airborne particles.
4. Please avoid the strong vibration or shock.
5. Ambient temperature change should be within 1deg. C/min.

■ Notice (Soldering and Mounting)

1. Excessive force or shock should be avoided to the product, especially to the metal cover.
2. Do not place the product near magnets, moving ferromagnetic materials, parts which generate magnetic field, high voltage lines or high current lines.
3. Do not place the product near high voltage lines or high current lines.
4. The terminal should be avoided to apply excessive force, to rotate or to bend.
5. Wiring should be avoided while supply voltage is

applied.

6. Hand soldering should be applied. Soldering should be done in following condition;
Soldering Temperature:
350 +-10deg. C less than 3 seconds
or 260 +-5deg. C less than 10 seconds.
7. Flux should be rosin and its chlorine content should be no more than 0.2wt%.
8. Flux cleaning should be done by hand brushing.
9. Prevent the flux cleaning solvent from splashing on the product.

■ Notice (Other)

1. This product is designed to detect magnetic properties of banknotes. Please contact us when using this product to detect any other magnetic properties than of banknotes.
2. Because this product contains a permanent magnet, Magnetic signals in a writable magnetic card such as train tickets or pre-paid cards could be damaged. Please consult with us before applying it in such circumstances.
3. BS05M1series;
To avoid unusual wear of the metal cover or jam of the banknote, around 0.1mm gap between the sensor and the opposite mechanisms such as rollers is recommended to reduce the load on the metal cover. The load of 0N is recommended.

4. BS05N series, BS05C series, BS05Wseries;
Please do not give the excessive force or shock on the sensing side. In the case of adhering the target media on the sensing side, please give same level of load throughout the sensor surface and the load should be less than 0.49N.
When a roller is set over the sensor, it should be cylindrical shape and its diameter greater than the width of sensor.
If the area coming in contact with sensor is smaller, the surface is worn partially and leads to some troubles.
5. Please mount this product with holder stuck firmly on the PCB in addition to solder terminals.

Data

■ Construction

Magnetic pattern recognition sensor consists of a pair of magnetoresistive (MR) elements and a magnet.

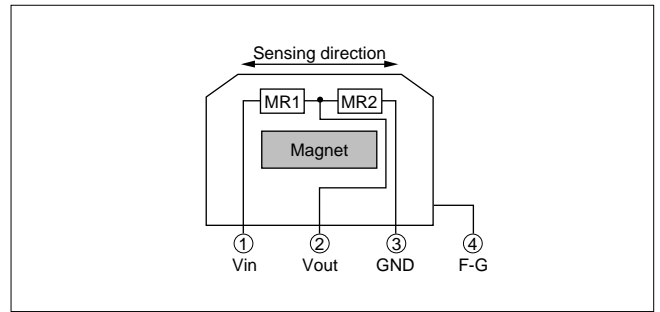

■ Magnetoresistive Effect

A change in the resistance of a ferromagnetic or semiconductive material when it is subjected to magnetic flux. Used in Murata's sensor is InSb which exhibits very high magnetoresistive effect.

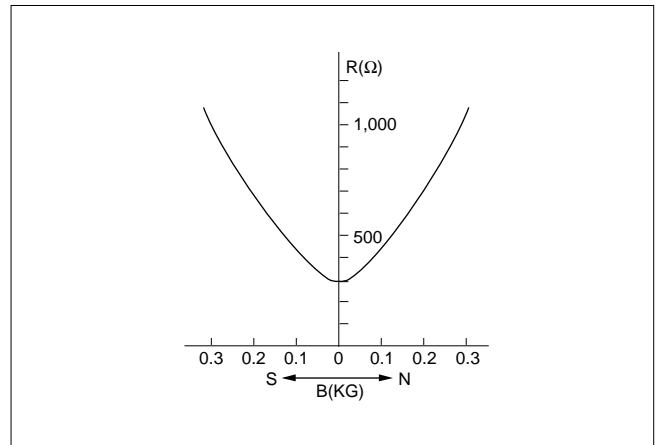

■ Principle of Operation

When a material printed with magnetic ink is scanned over the sensor, the magnetic flux applied to MR1 and MR2 changes. Thus, the sensor generates signals as indicated below.

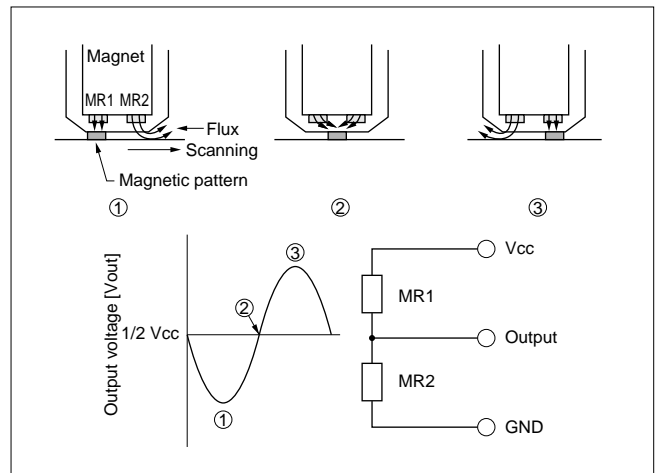

■ Typical Application

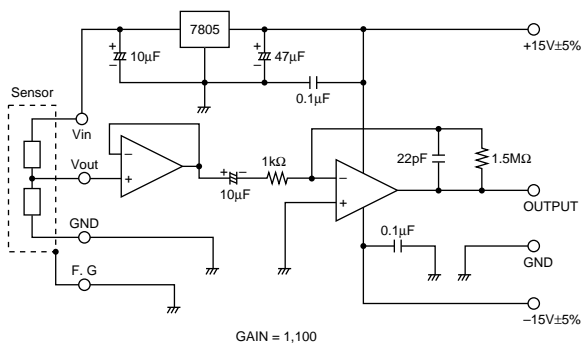

ISO 9000 Certifications/Part Numbering

Manufacturing plants of these products in this catalog have obtained the ISO 9000 quality system certificate

Plant	Certified Date	Organization	Registration No.
Kanazawa Murata Mfg. Co., Ltd. Included Nishikanazawa factory	Nov. 25, 1992	Reliability Center for Electronic Components of Japan	RCJ-92M-10

● **Part Numbering** (The structure of the "Global Part Numbers" that have been adopted since June 2001 and the meaning of each code are described herein.)
If you have any questions about details, inquire at your usual Murata sales office or distributor.

Magnetic Pattern Recognition Sensors

(Global Part Number) **BS** **05W** **1KFAB**

① ② ③ ④

- ① Product ID
- ② Type
- ③ Characteristics
- ④ Individual Specification Code

* Global Part Number shows only an example which might be different from actual part number.

* Any other definitions than "① Product ID" might have different digit number from actual Global Part Number.

⚠ Note:

1. Export Control

⟨For customers outside Japan⟩

Murata products should not be used or sold for use in the development, production, stockpiling or utilization of any conventional weapons or mass-destructive weapons (nuclear weapons, chemical or biological weapons, or missiles), or any other weapons.

⟨For customers in Japan⟩

For products which are controlled items subject to the "Foreign Exchange and Foreign Trade Law" of Japan, the export license specified by the law is required for export.

2. Please contact our sales representatives or product engineers before using our products listed in this catalog for the applications listed below which require especially high reliability for the prevention of defects which might directly cause damage to the third party's life, body or property, or when intending to use one of our products for other applications than specified in this catalog.

- | | |
|-----------------------------|---|
| ① Aircraft equipment | ② Aerospace equipment |
| ③ Undersea equipment | ④ Power plant equipment |
| ⑤ Medical equipment | ⑥ Transportation equipment (vehicles, trains, ships, etc.) |
| ⑦ Traffic signal equipment | ⑧ Disaster prevention / crime prevention equipment |
| ⑨ Data-processing equipment | ⑩ Application of similar complexity and/or reliability requirements to the applications listed in the above |

3. Product specifications in this catalog are as of January 2002. They are subject to change or our products in it may be discontinued without advance notice. Please check with our sales representatives or product engineers before ordering. If there are any questions, please contact our sales representatives or product engineers.

4. Please read rating and ⚠CAUTION (for storage and operating, rating, soldering and mounting, handling) in this catalog to prevent smoking and/or burning, etc.

5. This catalog has only typical specifications because there is no space for detailed specifications. Therefore, please approve our product specification or transact the approval sheet for product specification before ordering.

6. Please read CAUTION and Notice in this catalog for safety. This catalog has only typical specifications. Therefore you are requested to approve our product specification or to transact the approval sheet for product specification, before ordering.

7. Please note that unless otherwise specified, we shall assume no responsibility whatsoever for any conflict or dispute that may occur in connection with the effect of our and/or third party's intellectual property rights and other related rights in consideration of your using our products and/or information described or contained in our catalogs. In this connection, no representation shall be made to the effect that any third parties are authorized to use the rights mentioned above under licenses without our consent.

8. No ozone depleting substances (ODS) under the Montreal Protocol are used in our manufacturing process.