

671 824



**Advanced
Micro
Devices**

Am26LS31

Quad High Speed Differential Line Driver

DISTINCTIVE CHARACTERISTICS

- Output skew – 2.0 ns typical
- Input to output delay – 12 ns
- Operation from single +5 V supply
- 16-pin hermetic and molded DIP package
- Outputs won't load line when $V_{cc} = 0$
- Four line drivers in one package for maximum package density
- Output short-circuit protection
- Complementary outputs
- Meets the requirements of EIA standard RS-422
- High output drive capability for 100 Ω terminated transmission lines
- Available in military and commercial temperature range
- Advanced low-power Schottky processing

GENERAL DESCRIPTION

The Am26LS31 is a quad-differential line driver, designed for digital data transmission over balanced lines. The Am26LS31 meets all the requirements of EIA standard RS-422 and federal standard 1020. It is designed to provide unipolar differential drive to twisted-pair or parallel-wire transmission lines.

3-state outputs and logical OR-ed complementary enable inputs. The inputs are all LS compatible and are all one unit load.

The Am26LS31 is constructed using advanced low-power Schottky processing.

The circuit provides an enable and disable function common to all four drivers. The Am26LS31 features

BLOCK DIAGRAM

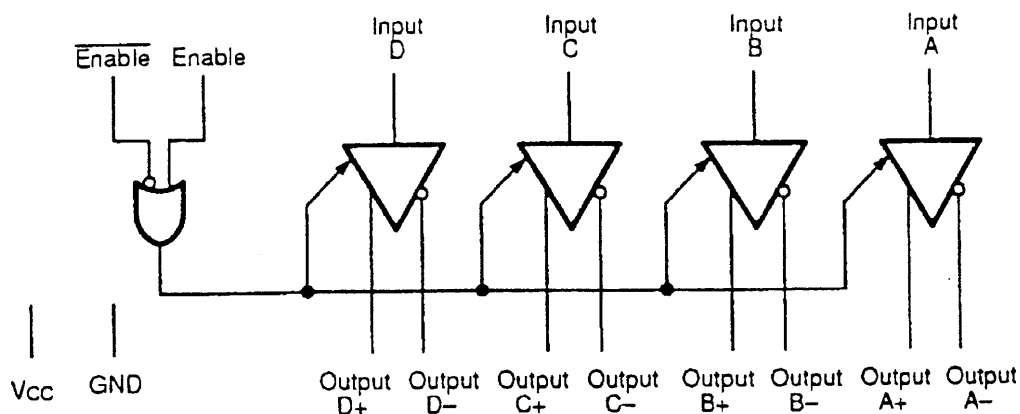

05392-001A

RELATED PRODUCTS

Part No.	Description
26LS30	Dual Differential RS-422 Party Line/Quad Single Ended RS-423 Line Driver
26LS32	Quad Differential RS-422 Line Receiver



PRELIMINARY

ORDERING INFORMATION

Standard Products

AMD standard products are available in several packages and operating ranges. The order number (Valid Combination) is formed by a combination of:

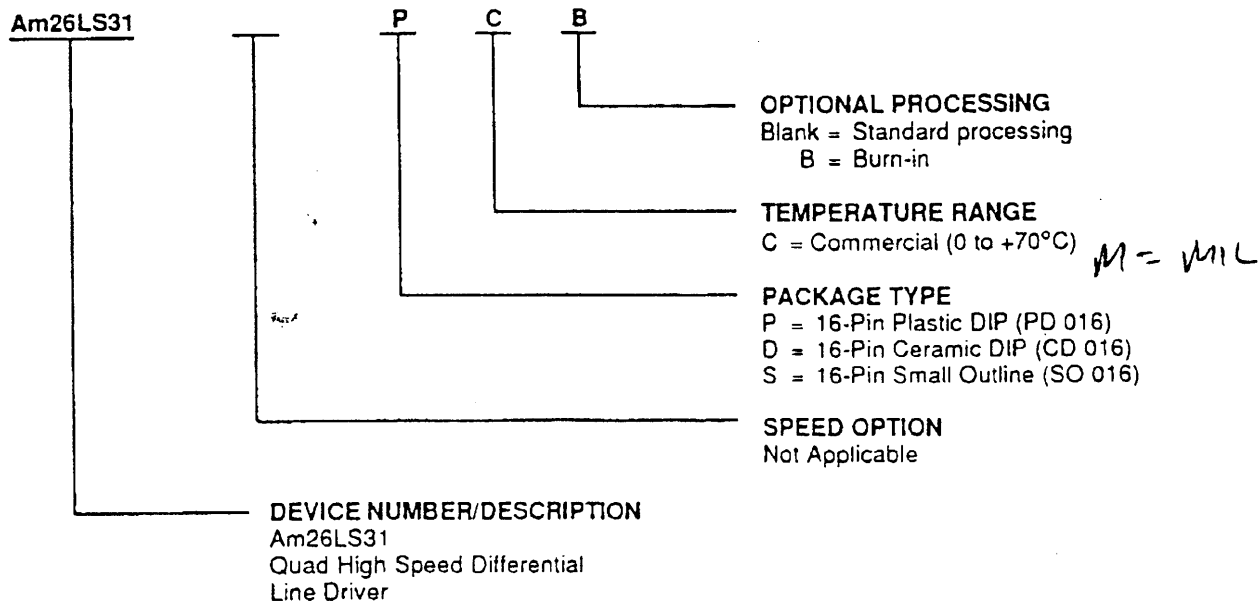

Valid Combinations	
AM26LS31	PC, PCB DC, DCB SC

Valid Combinations

Valid Combinations list configurations planned to be supported in volume for this device. Consult the local AMD sales office to confirm availability of specific valid combinations or to check on newly released combinations, and to obtain additional data on AMD's standard military grade products.

PRELIMINARY



MILITARY ORDERING INFORMATION

SMD/DESC Products

AMD products for Aerospace and Defense applications are available in several packages and operating ranges. Standard Military Drawing (SMD)/DESC products are fully compliant with MIL-STD-883C requirements. The order number (Valid Combination) is formed by a combination of:

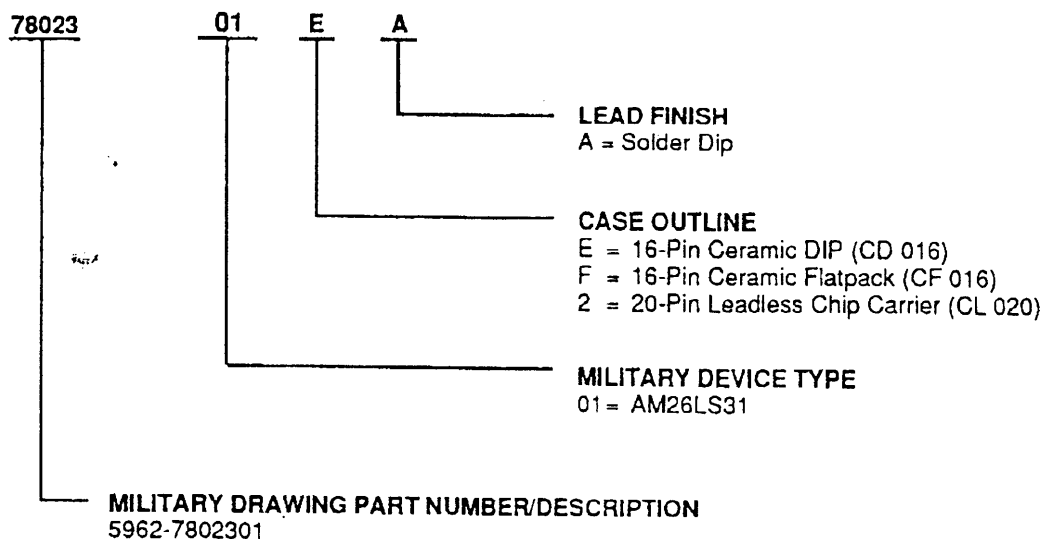

Valid Combinations	
5962-7802301	MEA, MFA, M2A

Valid Combinations

Valid Combinations list configurations planned to be supported in volume for this device. Consult the local AMD sales office to confirm availability of specific valid combinations, or to check on newly released combinations.

Group A Tests

Group A tests consist of Subgroups
1, 2, 3, 7, 8, 9, 10, 11.



PRELIMINARY

MILITARY ORDERING INFORMATION

APL Products

AMD products for Aerospace and Defense applications are available in several packages and operating ranges. APL (Approved Products List) products are fully compliant with MIL-STD-883C requirements. The order number (Valid Combination) is formed by a combination of:

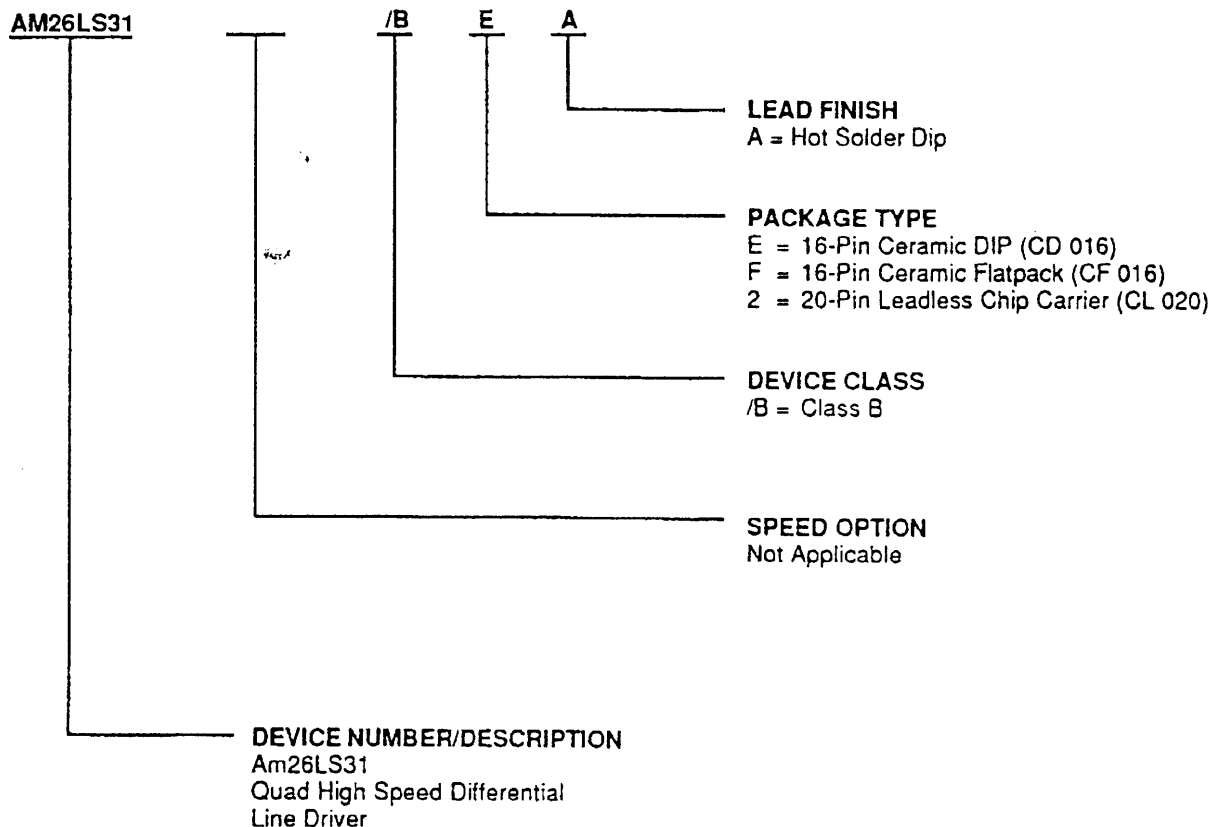

Valid Combinations	
Am26LS31	/BEA, /BFA, /B2A

Valid Combinations

Valid Combinations list configurations planned to be supported in volume for this device. Consult the local AMD sales office to confirm availability of specific valid combinations, or to check on newly released combinations.

Group A Tests

Group A tests consist of Subgroups 1, 2, 3, 7, 8, 9, 10, 11.

PRELIMINARY



TYPICAL APPLICATION

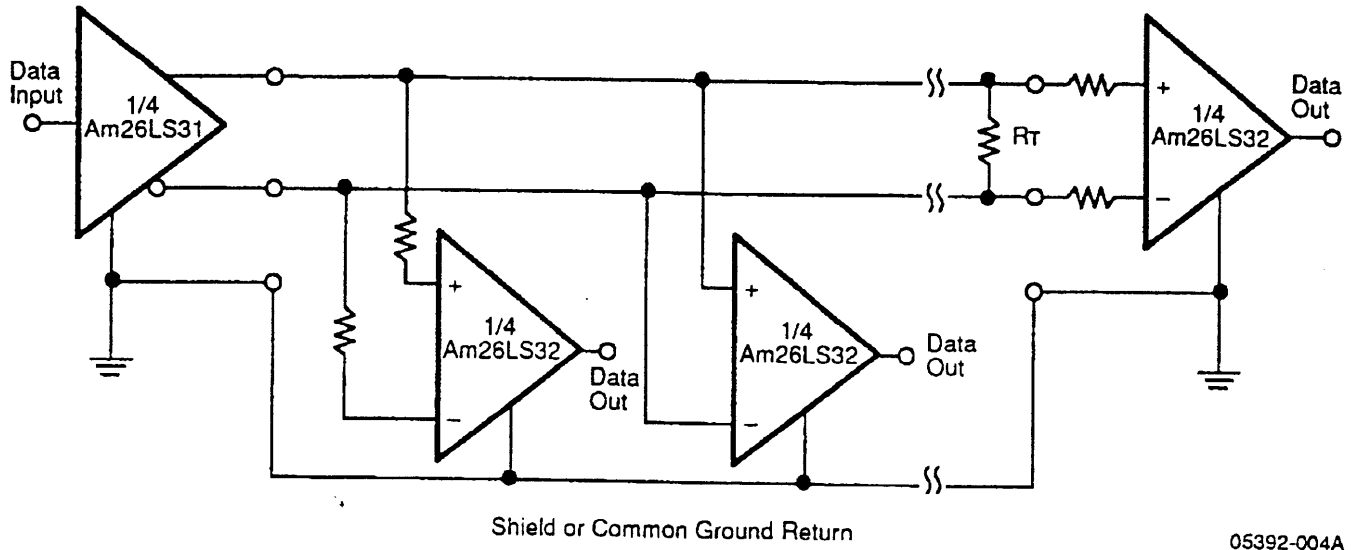

05392-004A



PRELIMINARY

ABSOLUTE MAXIMUM RATINGS

Storage Temperature	-65 to +150°C
Supply Voltage	-0.5 to 7.0 V
DC Input Voltage	-1.5 to 7.0 V
DC Output Voltage	-0.5 to V _{CC} max

Stresses above those listed under Absolute Maximum Ratings may cause permanent device failure. Functionality at or above these limits is not implied. Exposure to absolute maximum ratings for extended periods may affect device reliability.

OPERATING RANGES

Commercial (C) Devices

Ambient Temperature (T _A)	0 to +70°C
Supply Voltage (V _{CC})	+4.75 to +5.25 V

Military (M) Devices

Temperature	-55 to +125°C
Supply Voltage (V _{CC})	+4.5 to +5.5 V

Operating ranges define those limits between which the functionality of the device is guaranteed.

DC CHARACTERISTICS over operating ranges unless otherwise specified

Parameter Symbol	Parameter Description	Test Conditions (Note 2)	Min.	Typ. (Note 1)	Max.	Unit
V _{OH}	Output HIGH Voltage	V _{CC} = Min; I _{OH} = -20 mA	2.5	3.2		V
V _{OL}	Output LOW Voltage	V _{CC} = Min; I _{OL} = 20 mA		0.32	0.5	V
V _{IH}	Input HIGH Voltage	V _{CC} = Min; (Note 3)	2.0			V
V _{IL}	Input LOW Voltage	V _{CC} = Max. (Note 3)			0.8	V
I _{IL}	Input LOW Current	V _{CC} = Max., V _{IN} = 0.4 V		-0.20	-0.36	mA
I _{IH}	Input HIGH Current	V _{CC} = Max., V _{IN} = 2.7 V		0.5	20	μA
I _I	Input Reverse Current	V _{CC} = Max., V _{IN} = 7.0 V			0.1	mA
I _O	Off-State (High-Impedance) Output Current	V _{CC} = Max. V _O = 2.5 V V _O = 0.5 V			20 -20	μA
V _I	Input CLAMP Voltage	V _{CC} = Min., I _{IN} = -18 mA		-0.8	-1.5	V
I _{OFF}	Power off leakage Current	V _{CC} = 0 V V _{OUT} = 6 V V _{OUT} = -2.5 V			100 -100	μA
I _{SC}	Output Short Circuit Current	V _{CC} = Max., (Note 4)	-30	-60	-150	mA
I _{CC}	Power Supply Current	V _{CC} = Max., all outputs disabled		60	80	mA

AC Parameters V_{CC} = 5.0 V, T_A = 25°C

t _{PLH}	Input to Output	V _{CC} = 5.0 V, T _A = 25°C, Load = Note 2		12	20	ns
t _{PHL}	Input to Output	V _{CC} = 5.0 V, T _A = 25°C, Load = Note 2		12	20	ns
SKEW	Output to Output	V _{CC} = 5.0 V, T _A = 25°C, Load = Note 2		2.0	6.0	ns
t _{LZ}	Enable to Output	V _{CC} = 5.0 V, T _A = 25°C, C _L = 10 pF R _{L1} = 180 Ω, R _{L2} = 75 Ω		23	35	ns
t _{HZ}	Enable to Output	V _{CC} = 5.0 V, T _A = 25°C, C _L = 10 pF R _{L1} = 180 Ω, R _{L2} = 75 Ω		17	30	ns
t _{ZL}	Enable to Output	V _{CC} = 5.0 V, T _A = 25°C, Load = Note 2		35	45	ns
t _{ZH}	Enable to Output	V _{CC} = 5.0 V, T _A = 25°C, Load = Note 2		30	40	ns

Notes:

- All typical values are V_{CC} = 5.0 V, T_A = 25°C.
- C_L = 30 pF, V_{IN} = 1.3 V to V_{OUT} = 1.3 V, V_{PULSE} = 0 V to +3.0 V, R_{L1} = 180 Ω, R_{L2} = 75 Ω.
- Input thresholds are tested during DC tests and may be done in combination with testing of other DC parameters.
- Not more than one output should be shorted at a time. Duration of the short circuit test should not exceed one second.

PRELIMINARY



SWITCHING CHARACTERISTICS

Parameter Symbol	Parameter Description	Test Conditions	Min.	Typ. (Note 1)	Max.	Unit
AC Parameters (Commercial) $V_{CC} = 4.75\text{ V} - 5.25\text{ V}$; $T_A = 0^\circ\text{C} - 70^\circ\text{C}$						
tPLH	Propagation Delay from Input to Output	$C_L = 30\text{ pF}$, $R_{L1} = 180\ \Omega$, $R_{L2} = 75\ \Omega$		18	30	ns
tPHL	Propagation Delay from Input to Output	$C_L = 30\text{ pF}$, $R_{L1} = 180\ \Omega$, $R_{L2} = 75\ \Omega$		18	30	ns
tsKEW	Output to Output	$C_L = 30\text{ pF}$, $R_{L1} = 180\ \Omega$, $R_{L2} = 75\ \Omega$		3.0	9.0	ns
tPLZ	Propagation Delay from Enable to Output	$C_L = 10\text{ pF}$, $R_{L1} = 180\ \Omega$, $R_{L2} = 75\ \Omega$		35	53	ns
tPHZ	Propagation Delay from Enable to Output	$C_L = 10\text{ pF}$, $R_{L1} = 180\ \Omega$, $R_{L2} = 75\ \Omega$		25	45	ns
tpZL	Propagation Delay from Enable to Output	$C_L = 30\text{ pF}$, $R_{L1} = 180\ \Omega$, $R_{L2} = 75\ \Omega$		53	68	ns
tpZH	Propagation Delay from Enable to Output	$C_L = 30\text{ pF}$, $R_{L1} = 180\ \Omega$, $R_{L2} = 75\ \Omega$		45	60	ns
AC Parameters (Military) $V_{CC} = 4.75\text{ V} - 5.25\text{ V}$; $T_A = -55^\circ\text{C} - +125^\circ\text{C}$						
tPLH	Propagation Delay from Input to Output	$C_L = 30\text{ pF}$, $R_{L1} = 180\ \Omega$, $R_{L2} = 75\ \Omega$		18	30	ns
tPHL	Propagation Delay from Input to Output	$C_L = 30\text{ pF}$, $R_{L1} = 180\ \Omega$, $R_{L2} = 75\ \Omega$		18	30	ns
tsKEW	Output to Output	$C_L = 30\text{ pF}$, $R_{L1} = 180\ \Omega$, $R_{L2} = 75\ \Omega$		3.0	9.0	ns
tPLZ	Propagation Delay from Enable to Output	$C_L = 10\text{ pF}$, $R_{L1} = 180\ \Omega$, $R_{L2} = 75\ \Omega$		35	53	ns
tPHZ	Propagation Delay from Enable to Output	$C_L = 10\text{ pF}$, $R_{L1} = 180\ \Omega$, $R_{L2} = 75\ \Omega$		25	45	ns
tpZL	Propagation Delay from Enable to Output	$C_L = 30\text{ pF}$, $R_{L1} = 180\ \Omega$, $R_{L2} = 75\ \Omega$		53	68	ns
tpZH	Propagation Delay from Enable to Output	$C_L = 30\text{ pF}$, $R_{L1} = 180\ \Omega$, $R_{L2} = 75\ \Omega$		45	60	ns



PRELIMINARY

PERFORMANCE CURVES

Guaranteed V_{OH} and V_{OL}
($T_A = -55^\circ\text{C}$ to $+125^\circ\text{C}$)

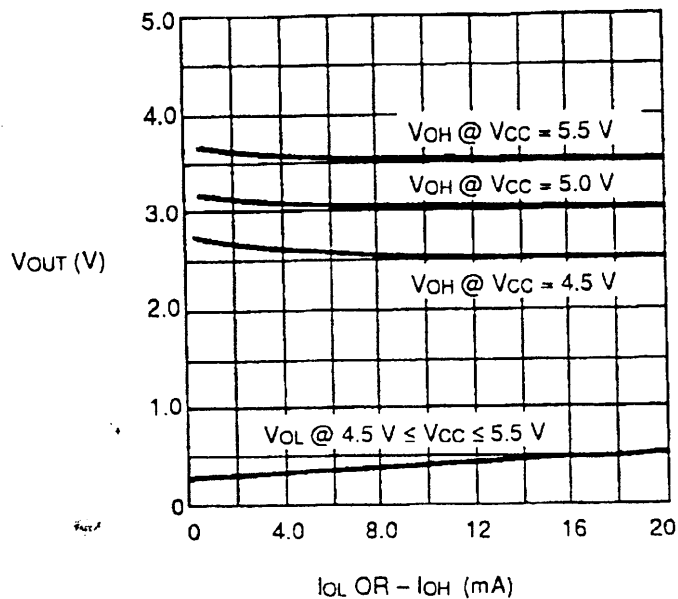

05392-005A

V_{OUT} Versus V_{CC}

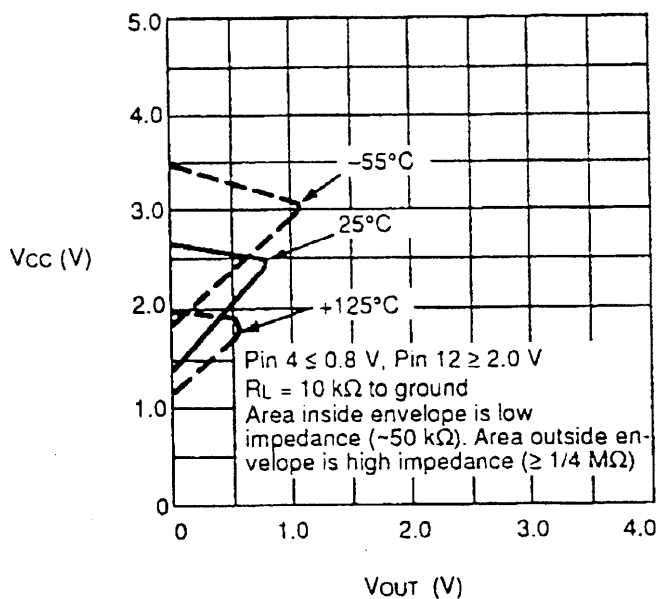

05392-006A

PRELIMINARY



KEY TO SWITCHING WAVEFORMS

WAVEFORM	INPUTS	OUTPUTS
	Must Be Steady	Will Be Steady
	May Change from H to L	Will Be Changing from H to L
	May Change from L to H	Will Be Changing from L to H
	Don't Care, Any Change Permitted	Changing State Unknown
	Does Not Apply	Center Line is High Impedance "Off" State

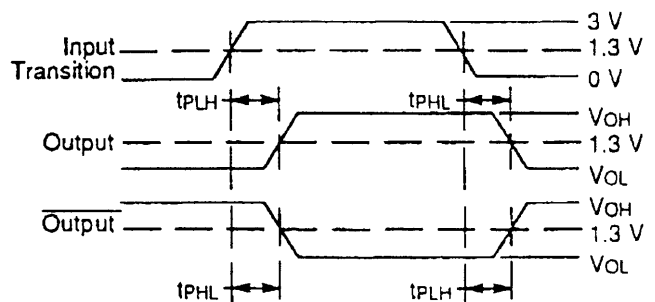

05392-008B

Propagation Delay
(Notes 1 and 3)

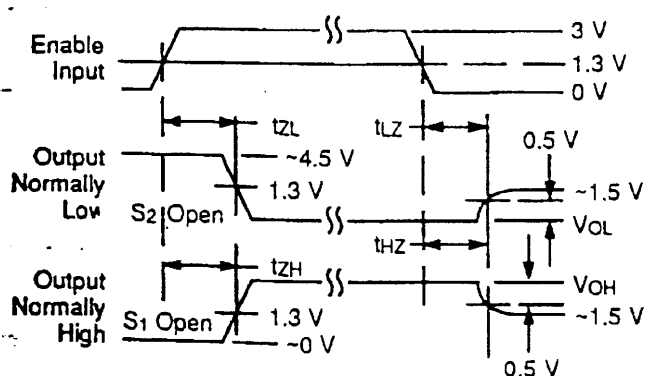

05392-009A

Enable and Disable Times
(Notes 2 and 3)

Notes:

1. Diagram shown for **Enable LOW**.
2. S₁ and S₂ of Load Circuit are closed except where shown.
3. Pulse Generator for All Pulses: Rate ≤ 1.0 MHz; Z₀ = 50 Ω; t_r ≤ 15 ns; t_f ≤ 6.0 ns.



PRELIMINARY

SWITCHING TEST CIRCUIT

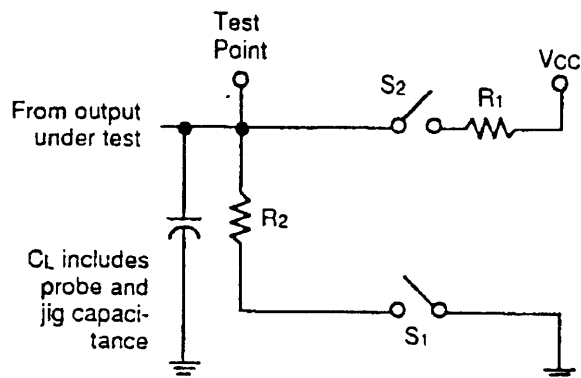

05392-007B

Three-State Outputs

EQUIVALENT CIRCUIT (1/4 Am26LS31)

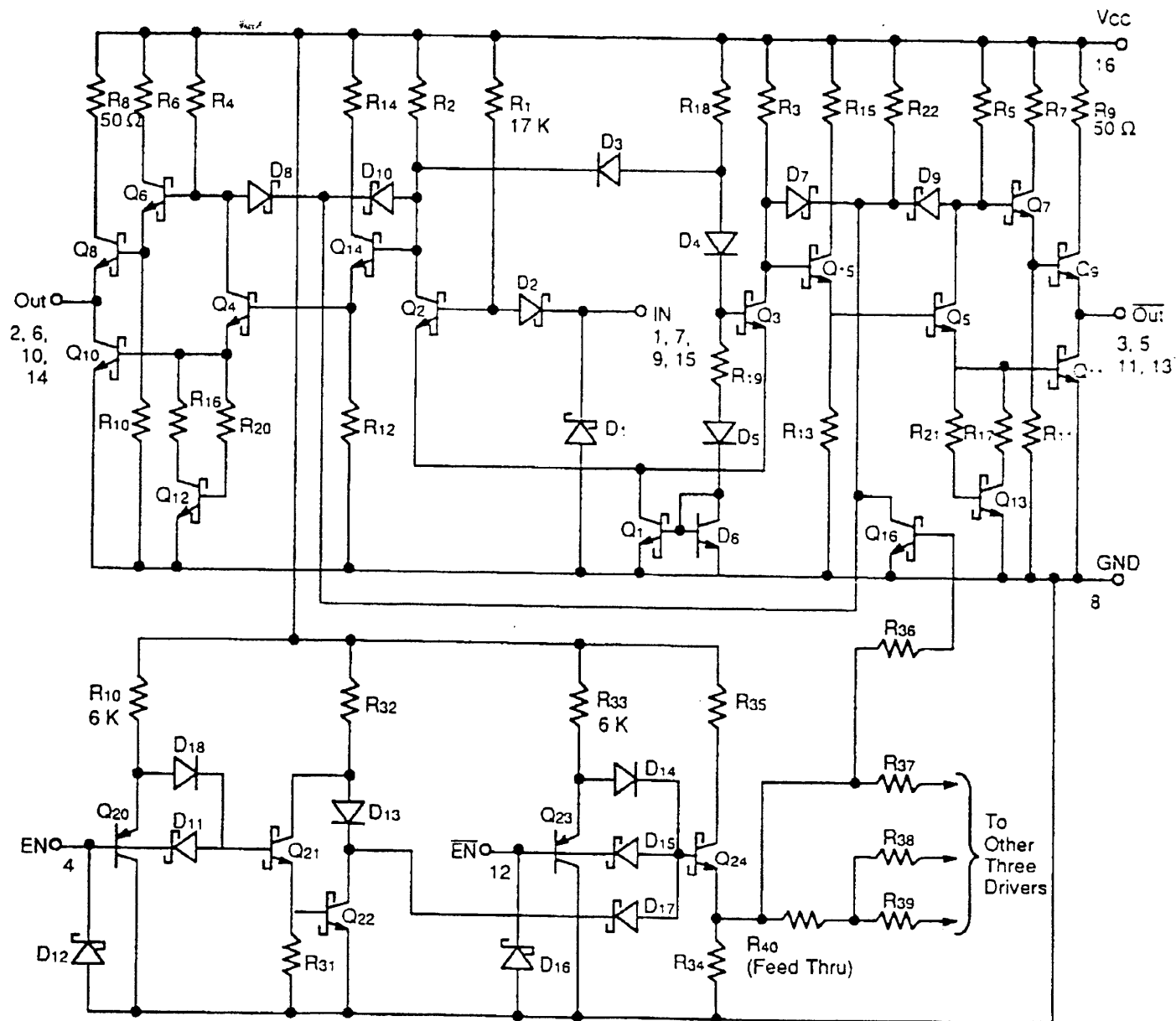

05392-010A