

MHDTZK Series - Die Cast D Hoods Top Entry

Low cost, high quality hood suitable for most demanding RFI/EMI screening requirements.

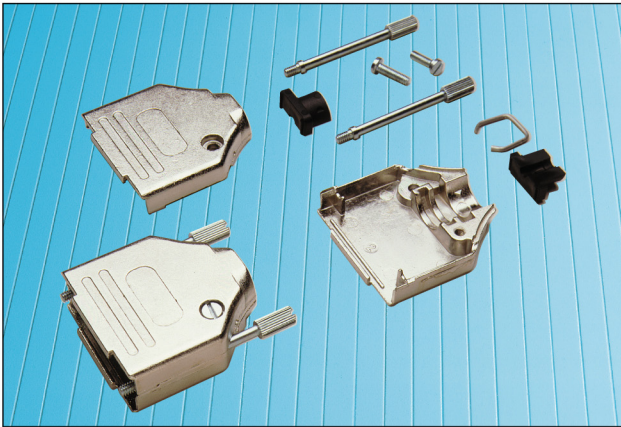

Order Code

MHDTZK 25 - B - K

Series _____
 Size _____
 9,15,25 & 37
 Plating Select _____
 Omit = Nickel
 B - Black chromate
 Packing Style _____
 Omit = Bulk
 K = Individually Kitted

- Meets VDE 0871, FCC 20780 and 89/EEC requirements, when part of an approved system.
- Light weight zinc die cast shell, nickel plated over copper.
- Turned full metal 4-40UNC thumbscrews (other thread sizes available to order).
- Conductive plastic strain relief inserts ensure all cable sizes from 3.5mm to 13mm are accommodated.

- Attenuation better than 40dB over the range 30 MHz to 1GHz.
- Unique sprung steel shielding support suitable for both foil and braided cable types.
- Company logo's available.

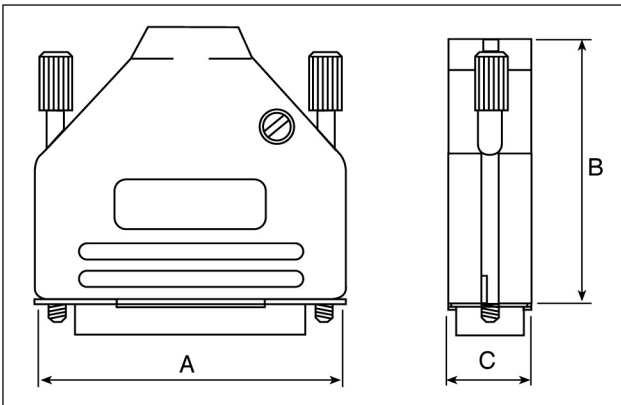

Ways	Dim A	Dim B
9	31.2	39.9
15	39.5	41.5
25	53.4	48.6
37	69.7	53.6

Assembly Instructions

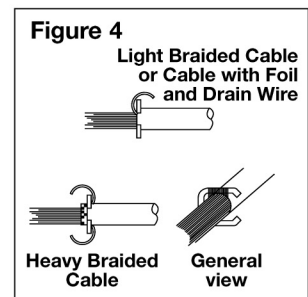
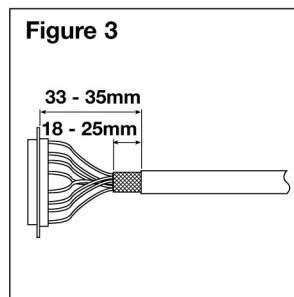
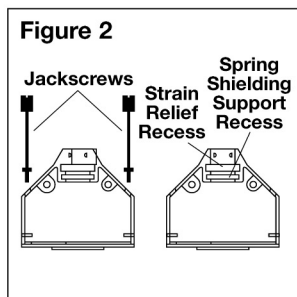
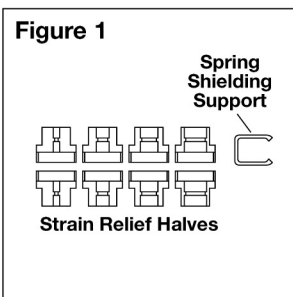

1. Prepare the cable as shown in Figure 3 and assemble to the connector.
2. Choose the strain relief halves that most closely match the cable O/D and place one into each recess, as shown in Figures 1 and 2. They do not need to be matching halves.
3. Use the metal shield support to isolate the braid/drain wire to the die cast shell, as shown in Figure 4.

4. Place the cable assembly/shield support into the appropriate recess in one half of the die cast cover. Ensure the cable is pressed into the strain relief piece.
5. Place the other half of the die cast hood into place and tighten together with the assembly screws.