

SN55116, SN75116, SN75117, SN75118, SN75119 DIFFERENTIAL LINE TRANSCEIVERS

SLLS073D – MAY 1976 – REVISED MAY 1998

features common to all types

- Single 5-V Supply
- 3-State Driver Output Circuitry
- TTL-Compatible Driver Inputs
- TTL-Compatible Receiver Output
- Differential Line Operation
- Receiver Output Strobe (SN55116, SN75116, SN75117) or Enable (SN75118, SN75119)
- Designed for Party-Line (Data-Bus) Applications

additional features of the SN55116/SN75116

- Choice of Ceramic or Plastic Packages
- Independent Driver and Receiver
- Choice of Open-Collector or Totem-Pole Outputs on Both Driver and Receiver
- Dual Data Inputs on Driver
- Optional Line-Termination Resistor in Receiver
- ± 15 -V Receiver Common-Mode Capability
- Receiver Frequency-Response Control

additional features of the SN75117

- Driver Output Internally Connected to Receiver Input

The SN75118 is an SN75116 With 3-State Receiver Output Circuitry
The SN75119 is an SN75117 With 3-State Receiver Output Circuitry

description

These integrated circuits are designed for use in interfacing between TTL-type digital systems and differential data-transmission lines. They are especially useful for party-line (data-bus) applications. Each of these circuit types combine in one package a 3-state differential line driver and a differential-input line receiver, both of which operate from a single 5-V power supply. The driver inputs and the receiver outputs are TTL compatible. The driver employed is similar to the SN55113 and SN75113 3-state line drivers, and the receiver is similar to the SN55115 and SN75115 line receivers.

The SN55116, SN75116, and SN75118 offer all the features of the SN55113 and SN75113 drivers and the SN55115 and SN75115 receivers combined. The driver performs the dual input AND and NAND functions when enabled or presents a high impedance to the load when in the disabled state. The driver output stages are similar to TTL totem-pole outputs, but have the current-sinking portion separated from the current-sourcing portion and both are brought out to adjacent package terminals. This feature allows the user the option of using the driver in the open-collector output configuration, or, by connecting the adjacent source and sink terminals together, of using the driver in the normal totem-pole output configuration.

The receiver portion of the SN55116, SN75116, and SN75118 features a differential-input circuit having a common-mode voltage range of ± 15 V. An internal 130- Ω equivalent resistor also is provided, which optionally can be used to terminate the transmission line. A frequency-response control terminal allows the user to reduce the speed of the receiver or to improve differential noise immunity. The receivers of the SN55116 and SN75116 have an output strobe and a split totem-pole output. The receiver of the SN75118 has an output-enable for the 3-state split totem-pole output. The receiver section of either circuit is independent of the driver section except for the V_{CC} and ground terminals.

The SN75117 and SN75119 provide the basic driver and receiver functions of the SN55116, SN75116, and SN75118, but use a package that is only half as large. The SN75117 and SN75119 are intended primarily for party-line or bus-organized systems because the driver outputs are internally connected to the receiver inputs. The driver has a single data input and a single enable input. The SN75117 receiver has an output strobe, while the SN75119 receiver has a 3-state output enable. However, these devices do not provide output connection options, line-termination resistors, or receiver frequency-response controls.



Please be aware that an important notice concerning availability, standard warranty, and use in critical applications of Texas Instruments semiconductor products and disclaimers thereto appears at the end of this data sheet.

PRODUCTION DATA information is current as of publication date. Products conform to specifications per the terms of Texas Instruments standard warranty. Production processing does not necessarily include testing of all parameters.

 **TEXAS
INSTRUMENTS**

POST OFFICE BOX 655303 • DALLAS, TEXAS 75265
POST OFFICE BOX 1443 • HOUSTON, TEXAS 77251-1443

Copyright © 1998, Texas Instruments Incorporated

SN55116, SN75116, SN75117, SN75118, SN75119 DIFFERENTIAL LINE TRANSCEIVERS

SLLS073D – MAY 1976 – REVISED MAY 1998

description (continued)

The SN55116 is characterized for operation over the full military temperature range of -55°C to 125°C . The SN75116, SN75117, SN75118, and SN75119 are characterized for operation from 0°C to 70°C .

SN55116 . . . J PACKAGE
SN75116 . . . D OR N PACKAGE
(TOP VIEW)

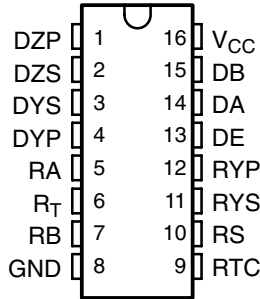

SN75118 . . . D OR N PACKAGE
(TOP VIEW)

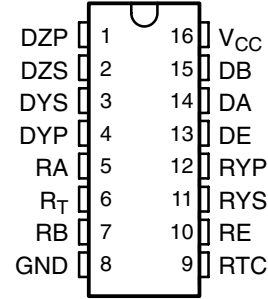

SN55116 . . . FK PACKAGE
(TOP VIEW)

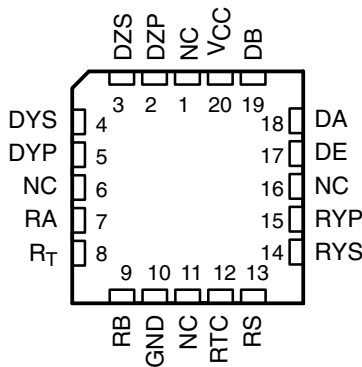

NC – No internal connection

SN75117 . . . D OR P PACKAGE
(TOP VIEW)

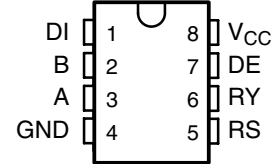

SN75119 . . . D OR P PACKAGE
(TOP VIEW)

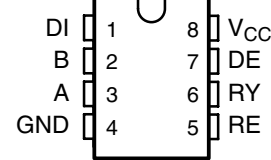

Function Tables

'116, SN75118
DRIVER

INPUTS			OUTPUTS	
DE	DA	DB	DY	DZ
L	X	X	Z	Z
H	L	X	L	H
H	X	L	L	H
H	H	H	H	L

'116, SN75118
RECEIVER

RS/RE	DIFF INPUT	OUTPUTS RY	
		'116	SN75118
L	X	H	Z
H	L	H	H
H	H	L	L

SN75117, SN75119
DRIVER

INPUTS		OUTPUTS	
DI	DE	A	B
H	H	H	L
L	H	L	H
X	L	Z	Z

SN75117, SN75119
RECEIVER

INPUTS			OUTPUT RY	
A	B	RS/RE	SN75117	SN75119
H	L	H	H	H
L	H	H	L	L
X	X	L	H	Z

H = high level ($V_I \geq V_{IH}$ min or V_{ID} more positive than V_{TH} max), L = low level ($V_I \leq V_{IL}$ max or V_{ID} more negative than V_{TL} max), X = irrelevant, Z = high impedance (off)

SN55116, SN75116, SN75117, SN75118, SN75119 DIFFERENTIAL LINE TRANSCEIVERS

SLLS073D - MAY 1976 - REVISED MAY 1998

logic symbol†

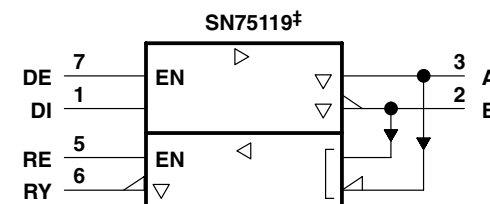
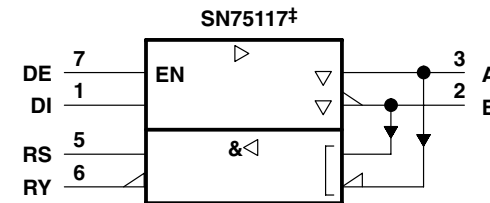
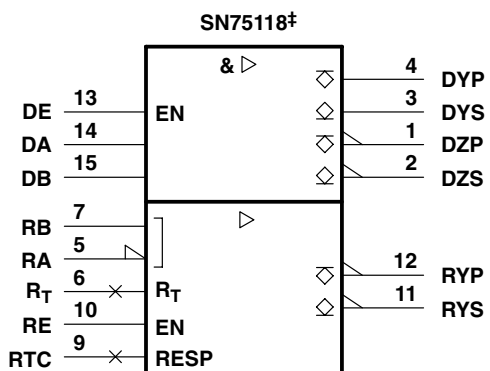
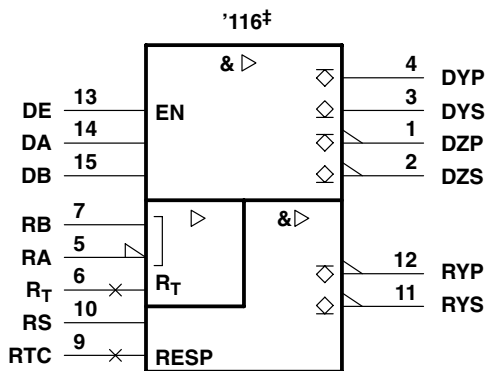

logic diagram (positive logic)

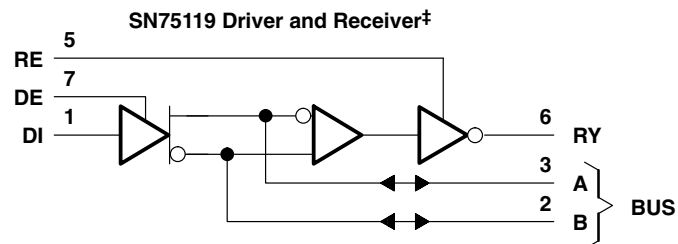
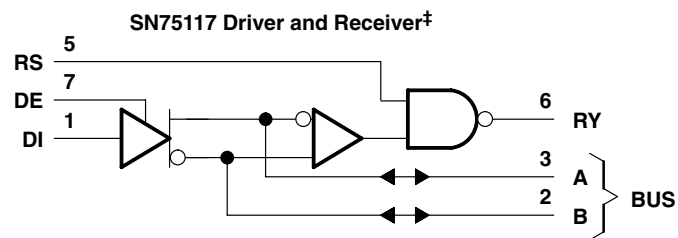
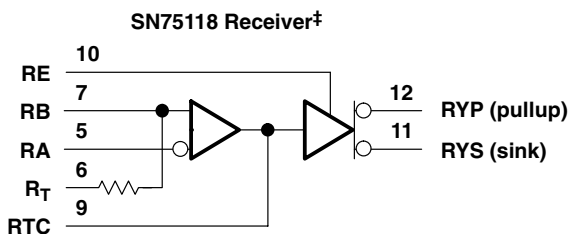
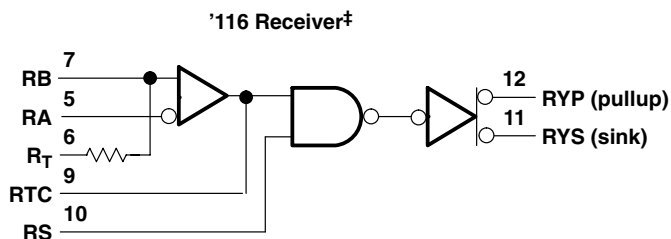
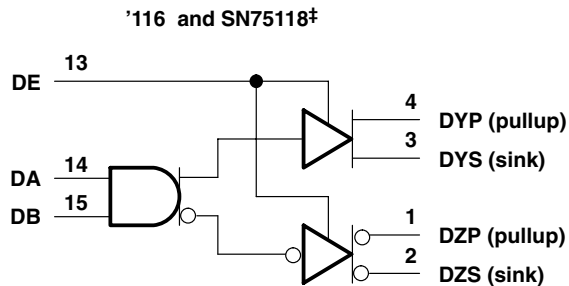

† These symbols are in accordance with ANSI/IEEE Std 91-1984 and IEC Publication 617-12.

‡ Pin numbers shown for the SN55116 and SN75116 are for the D, J, and N packages, those shown for the SN75118 are for the D and N packages, and those shown for SN75117 and SN75119 are for the D and P packages.

SN55116, SN75116, SN75117, SN75118, SN75119 DIFFERENTIAL LINE TRANSCEIVERS

SLLS073D – MAY 1976 – REVISED MAY 1998

schematics of inputs and outputs

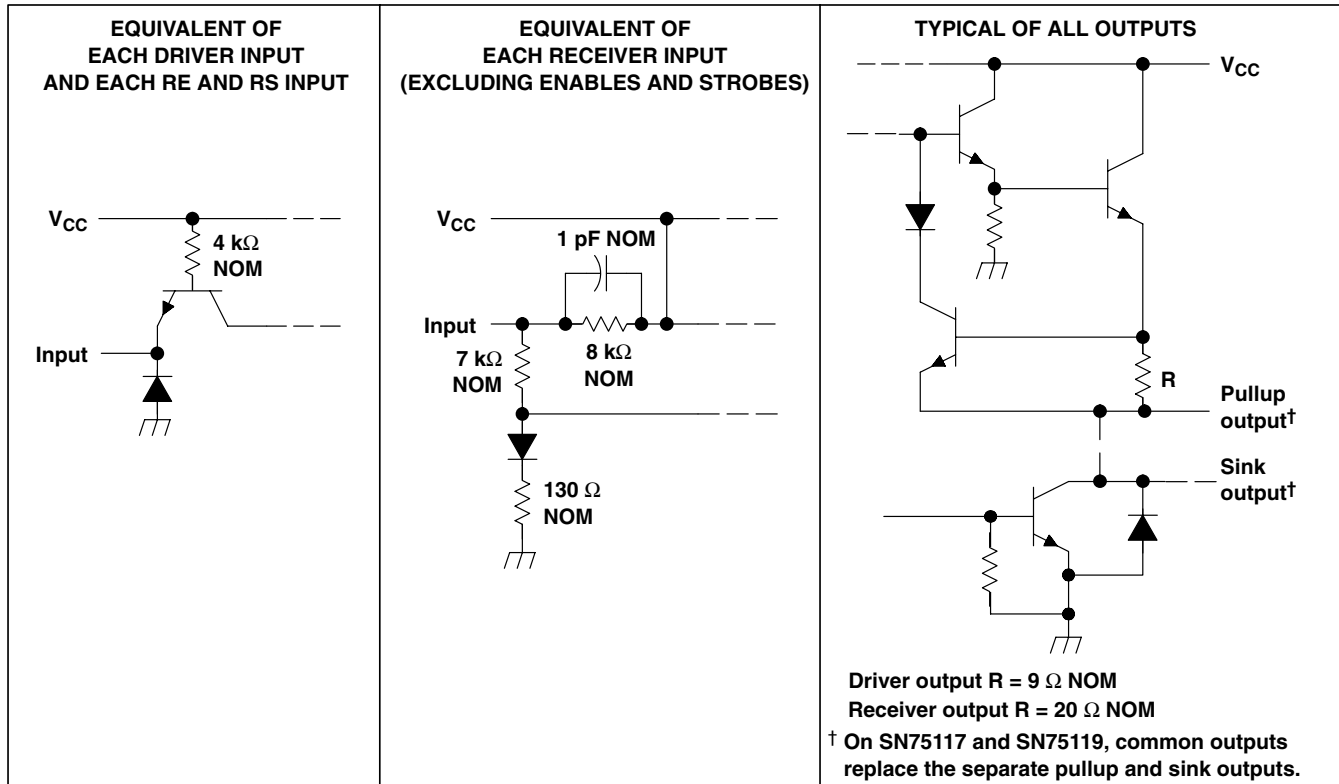

absolute maximum ratings over operating free-air temperature (unless otherwise noted)‡

Supply voltage, V_{CC} (see Notes 1 and 2)	7 V
Input voltage, V_I : DA, DB, DE, DI, RE, and RS	5.5 V
RA, RB, R_T for '116, SN75118 only	± 25 V
A and B for SN75117, SN75119 only	0 to 6 V
Off-state voltage applied to open-collector outputs: '116, SN75118 only	12 V
Continuous total power dissipation (see Note 2)	See Dissipation Rating Table
Storage temperature range, T_{stg}	-65°C to 150°C
Case temperature for 60 seconds, T_C : FK package	260°C
Lead temperature 1,6 mm (1/16 inch) from case for 60 seconds: J package	300°C
Lead temperature 1,6 mm (1/16 inch) from case for 10 seconds: D, N, or P package	260°C

‡ Stresses beyond those listed under "absolute maximum ratings" may cause permanent damage to the device. These are stress ratings only, and functional operation of the device at these or any other conditions beyond those indicated under "recommended operating conditions" is not implied. Exposure to absolute-maximum-rated conditions for extended periods may affect device reliability.

- NOTES: 1. All voltage values are with respect to the network ground terminal.
2. In the FK and J packages, the SN55116 chip is alloy mounted. The SN75116, SN75117, SN75118, and SN75119 chips are glass mounted.



SN55116, SN75116, SN75117, SN75118, SN75119 DIFFERENTIAL LINE TRANSCEIVERS

SLLS073D – MAY 1976 – REVISED MAY 1998

DISSIPATION RATING TABLE

PACKAGE	$T_A \leq 25^\circ\text{C}$ POWER RATING	DERATING FACTOR ABOVE $T_A = 25^\circ\text{C}$	$T_A = 70^\circ\text{C}$ POWER RATING	$T_A = 125^\circ\text{C}$ POWER RATING
D (8 pin)	725 mW	5.8 mW/ $^\circ\text{C}$	464 mW	—
D (16 pin)	950 mW	7.6 mW/ $^\circ\text{C}$	608 mW	—
FK	1375 mW	11.0 mW/ $^\circ\text{C}$	880 mW	275 mW
J	1375 mW	11.0 mW/ $^\circ\text{C}$	880 mW	275 mW
N	1150 mW	9.2 mW/ $^\circ\text{C}$	736 mW	—
P	1000 mW	8.0 mW/ $^\circ\text{C}$	640 mW	—

recommended operating conditions

PARAMETER		SN55116			SN75116, SN75117, SN75118, SN75119			UNIT	
		MIN	NOM	MAX	MIN	NOM	MAX		
Supply voltage, V_{CC}		4.5	5	5.5	4.5	5	5.5	V	
High-level input voltage, V_{IH}	All inputs except differential inputs	2			2			V	
Low-level input voltage, V_{IL}		0.8			0.8			V	
High-level output current, I_{OH}	Drivers	-40			-40			mA	
	Receivers	-5			-5				
Low-level output current, I_{OL}	Drivers	40			40			mA	
	Receivers	15			15				
Receiver input voltage, V_I	'116, SN75118	± 15			± 15			V	
	SN75117, SN75119	0	6		0	6			
Common-mode receiver input voltage, V_{ICR}	'116, SN75118	± 15			± 15			V	
	SN75117, SN75119	0	6		0	6			
Operating free-air temperature, T_A		-55		125		0		70	$^\circ\text{C}$



electrical characteristics over recommended operating free-air temperature range (unless otherwise noted)

driver section

PARAMETER		TEST CONDITIONS†		'116, SN75118			SN75117, SN75119			UNIT
				MIN	TYP‡	MAX	MIN	TYP‡	MAX	
V _{IK}	Input clamp voltage	V _{CC} = MIN, I _I = -12 mA		-0.9	-1.5		-0.9	-1.5	V	
V _{OH}	High-level output voltage	V _{CC} = MIN, V _{IL} = 0.8 V, I _{IH} = 2 V	T _A = 25°C (SN55116), T _A = 0°C to 70°C (SN75116, SN75117, SN75118, SN75119)	I _{OH} = -10 mA	2.4	3.4	2.4	3.4	V	
				I _{OH} = -40 mA	2	3	2	3		
			T _A = -55°C to 125°C (SN55116)	I _{OH} = -10 mA	2		2			
				I _{OH} = -40 mA	1.8		1.8			
V _{OL}	Low-level output voltage	V _{CC} = MIN, V _{IH} = 2 V, V _{IL} = 0.8 V, I _{OL} = 40 mA			0.4		0.4	V		
V _{OK}	Output clamp voltage	V _{CC} = MAX, I _O = -40 mA, DE at 0.8 V			-1.5		-1.5	V		
I _{O(off)}	Off-state open-collector output current	V _{CC} = MAX, V _O = 12 V	T _A = 25°C		1	10		μA		
			T _A = MAX	SN55116		200				
I _{OZ}	Off-state (high-impedance-state) output current	V _{CC} = MAX, DE at 0.8 V, T _A = MAX	V _O = 0 to V _{CC} , DE at 0.8 V, T _A = 25°C		±10			μA		
			V _O = 0	SN55116		-300				
			V _O = 0.4 V to V _{CC}	SN55116		±150				
			V _O = 0 to V _{CC}	SN75116, SN75118		±20				
I _I	Input current at maximum input voltage	Driver or enable input	V _{CC} = MAX, V _I = 5.5 V			1		1	mA	
I _{IH}	High-level input current		V _{CC} = MAX, V _I = 2.4 V			40		40	μA	
I _{IL}	Low-level input current		V _{CC} = MAX, V _I = 0.4 V			-1.6		-1.6	mA	
I _{OS}	Short-circuit output current§	V _{CC} = MAX, V _O = 0, T _A = 25°C		-40	-120	-40	-120	mA		
I _{CC}	Supply current (driver and receiver combined)	V _{CC} = MAX, T _A = 25°C		42	60	42	60	mA		

† All parameters with the exception of off-state open-collector output current are measured with the active pullup connected to the sink output. For conditions shown as MIN or MAX, use the appropriate value specified under recommended operating conditions.

‡ All typical values are at V_{CC} = 5 V and T_A = 25°C.

§ Not more than one output should be shorted at a time, and duration of the short circuit should not exceed one second.

SN55116, SN75116, SN75117, SN75118, SN75119 DIFFERENTIAL LINE TRANSCEIVERS

SLLS073D – MAY 1976 – REVISED MAY 1998

switching characteristics, $V_{CC} = 5\text{ V}$, $C_L = 30\text{ pF}$, $T_A = 25^\circ\text{C}$

driver section

PARAMETER		TEST CONDITIONS	MIN	TYP	MAX	UNIT
t_{PLH}	Propagation-delay time, low-to-high level output	See Figure 13		14	30	ns
t_{PHL}	Propagation-delay time, high-to-low level output			12	30	
t_{PZH}	Output-enable time to high level	$R_L = 180\ \Omega$, See Figure 14		8	20	ns
t_{PZL}	Output-enable time to low level	$R_L = 250\ \Omega$, See Figure 15		17	40	ns
t_{PHZ}	Output-disable time from high level	$R_L = 180\ \Omega$, See Figure 14		16	30	ns
t_{PLZ}	Output-disable time from low level	$R_L = 250\ \Omega$, See Figure 15		20	35	ns



electrical characteristics over recommended operating free-air temperature range (unless otherwise noted)

receiver section

PARAMETER		TEST CONDITION [†]		'116, SN75118			SN75117, SN75119			UNIT
				MIN	TYP [‡]	MAX	MIN	TYP [‡]	MAX	
V _{IT+}	Positive-going threshold voltage [§]	V _O = 0.4 V, See Note 3	I _{OL} = 15 mA,	V _{CC} = MIN, V _{ICR} = 0, See Note 4	0.5		0.5		V	
				V _{CC} = 5 V, V _{ICR} = MAX, See Note 5	1		1			
V _{IT-}	Negative-going threshold voltage [§]	V _O = 2.4 V, See Note 3	I _{OL} = -5 mA,	V _{CC} = MIN, V _{ICR} = 0, See Note 4	-0.5 [¶]		-0.5 [¶]		V	
				V _{CC} = 5 V, V _{ICR} = MAX, See Note 5	-1 [¶]		-1 [¶]			
V _I	Input voltage range [#]	V _{CC} = 5 V,	V _{ID} = -1 V or 1 V,	See Note 3		15 to -15	6 to 0	V		
V _{OH}	High-level output voltage	I _{OH} = -5 mA, See Note 3	V _{CC} = MIN, V _{ICR} = 0,	V _{ID} = -0.5 V, See Notes 4 and 6	2.4		2.4		V	
			V _{CC} = 5 V, V _{ICR} = MAX,	V _{ID} = -1 V, See Note 5	2.4		2.4			
V _{OL}	Low-level output voltage	I _{OL} = 15 mA, See Note 3	V _{CC} = MIN, V _{ICR} = 0,	V _{ID} = 0.5 V, See Notes 4 and 7	0.4		0.4		V	
			V _{CC} = 5 V, V _{ICR} = MAX,	V _{ID} = 1 V, See Note 5	0.4		0.4			
I _{I(rec)}	Receiver input current	V _{CC} = MAX, See Note 3	V _I = 0,	Other input at 0 V	-0.5	-0.9	-0.5	-1	mA	
			V _I = 0.4 V,	Other input at 2.4 V	-0.4	-0.7	-0.4	-0.8		
			V _I = 2.4 V,	Other input at 0.4 V	0.1	0.3	0.1	0.4		
I _I	Input current at maximum input voltage	Strobe	V _{CC} = MIN, V _{strobe} = 4.5 V	V _{ID} = -0.5 V,	'116, SN75117		5		5	μA
		Enable	V _{CC} = MAX,	V _I = 5.5 V	SN75118, SN75119		1		1	

[†] Unless otherwise noted, V_{strobe} = 2.4 V. All parameters, with the exception of off-state open-collector output current, are measured with the active pullup connected to the sink output.

For conditions shown as MIN or MAX, use the appropriate value specified under recommended operating conditions.

[‡] All typical values are at V_{CC} = 5 V, T_A = 25°C, and V_{IC} = 0.

[§] Differential voltages are at the B input terminal with respect to the A input terminal. Neither receiver input of the SN75117 or SN75119 should be taken negative with respect to GND.

[¶] The algebraic convention, where the less positive (more negative) limit is designated as minimum, is used in this data sheet for threshold voltages only.

[#] Input voltage range is the voltage range that, if exceeded at either input, will cause the receiver to cease functioning properly.

NOTES: 3. Measurement of these characteristics on the SN75117 and SN75119 requires the driver to be disabled with the driver enable at 0.8 V.

4. This applies with the less positive receiver input grounded.

5. For '116 and SN75118, this applies with the more positive receiver input at 15 V or the more negative receiver input at -15 V. For SN75117 and SN75119, this applies with the more positive receiver input at 6 V.

6. For SN55116, V_{ID} = -1 V

7. For SN55116, V_{ID} = 1 V

receiver section (continued)

PARAMETER			TEST CONDITIONS†			'116, SN75118			SN75117, SN75119			UNIT
						MIN	TYP‡	MAX	MIN	TYP‡	MAX	
I_{IH}	High-level input current	Enable	$V_{CC} = \text{MAX}$,	$V_I = 2.4 \text{ V}$	SN75118, SN75119		40			40	μA	
I_I	Low-level input current	Strobe	$V_{CC} = \text{MAX}$,	$V_{ID} = 0.5 \text{ V}$,	'116, SN75117		-2.4			-2.4	mA	
		Enable	$V_{CC} = \text{MAX}$,	$V_I = 0.4 \text{ V}$	SN75118, SN75119		-1.6			-1.6		
$I_{(RTC)}$	Response-time-control current (RTC)		$V_{CC} = \text{MAX}$,	$V_{ID} = 0.5 \text{ V}$,	$T_A = 25^\circ\text{C}$		-1.2				mA	
$I_{O(\text{off})}$	Off-state open-collector output current		$V_{CC} = \text{MAX}$,	$V_O = 12 \text{ V}$,	$V_{ID} = -1 \text{ V}$		$T_A = 25^\circ\text{C}$	1	10		μA	
I_{OZ}	Off-state (high-impedance-state) output current		$V_{CC} = \text{MAX}$,	$V_O = 0 \text{ to } V_{CC}$,	RE at 0.4 V		$T_A = 25^\circ\text{C}$	± 10		± 10	μA	
R_T	Line-terminating resistance		$V_{CC} = 5 \text{ V}$		$T_A = 25^\circ\text{C}$		77	167			Ω	
I_{OS}	Short-circuit output current§		$V_{CC} = \text{MAX}$,	$V_{ID} = -0.5 \text{ V}$,	$V_O = 0$,	$T_A = 25^\circ\text{C}$	-15	-80	-15	-80	mA	
I_{CC}	Short current (driver and receiver combined)		$V_{CC} = \text{MAX}$,	$V_{ID} = 0.5 \text{ V}$,	$T_A = 25^\circ\text{C}$		42	60	42	60	mA	

† Unless otherwise noted, $V_{\text{strobe}} = 2.4 \text{ V}$. All parameters, with the exception of off-state open-collector output current, are measured with the active pullup connected to the sink output. For conditions shown as MIN or MAX, use the appropriate value specified under recommended operating conditions.

‡ All typical values are at $V_{CC} = 5 \text{ V}$, $T_A = 25^\circ\text{C}$, and $V_{IC} = 0$.

§ Not more than one output should be shorted at a time.

NOTES: 4. This applies with the less positive receiver input grounded.

6. For SN55116, $V_{ID} = -1 \text{ V}$

7. For SN55116, $V_{ID} = 1 \text{ V}$

SN55116, SN75116, SN75117, SN75118, SN75119 DIFFERENTIAL LINE TRANSCEIVERS

SLLS073D – MAY 1976 – REVISED MAY 1998

switching characteristics, $V_{CC} = 5\text{ V}$, $C_L = 30\text{ pF}$, $T_A = 25^\circ\text{C}$

receiver section

PARAMETER		TEST CONDITIONS	MIN	TYP	MAX	UNIT
t_{PLH}	Propagation-delay time, low-to-high-level output	$R_L = 400\ \Omega$, See Figure 16		20	75	ns
t_{PHL}	Propagation-delay time, high-to-low-level output			17	75	ns
t_{PZH}	Output-enable time to high level	$R_L = 480\ \Omega$, See Figure 14		9	20	ns
t_{PZL}	Output-enable time to low level	$R_L = 250\ \Omega$, See Figure 15		16	35	ns
t_{PHZ}	Output-disable time from high level	$R_L = 480\ \Omega$, See Figure 14		12	30	ns
t_{PLZ}	Output-disable time from low level	$R_L = 250\ \Omega$, See Figure 15		17	35	ns



SN55116, SN75116, SN75117, SN75118, SN75119 DIFFERENTIAL LINE TRANSCEIVERS

SLLS073D – MAY 1976 – REVISED MAY 1998

TYPICAL CHARACTERISTICS†

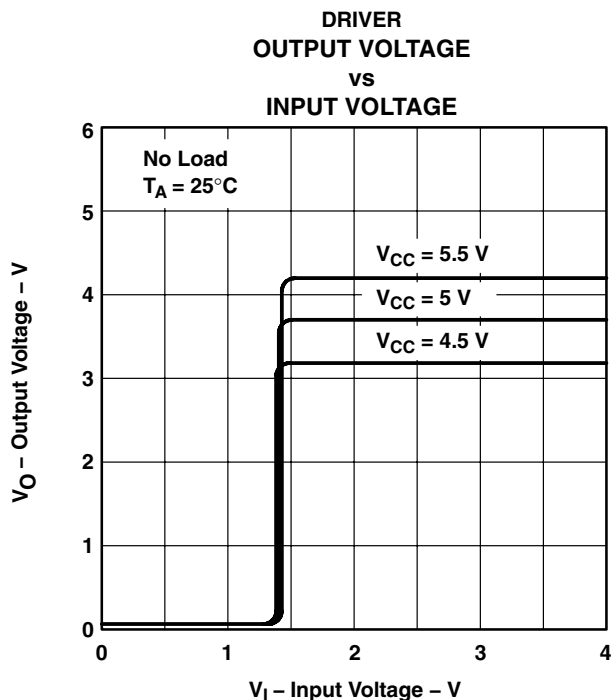

Figure 1

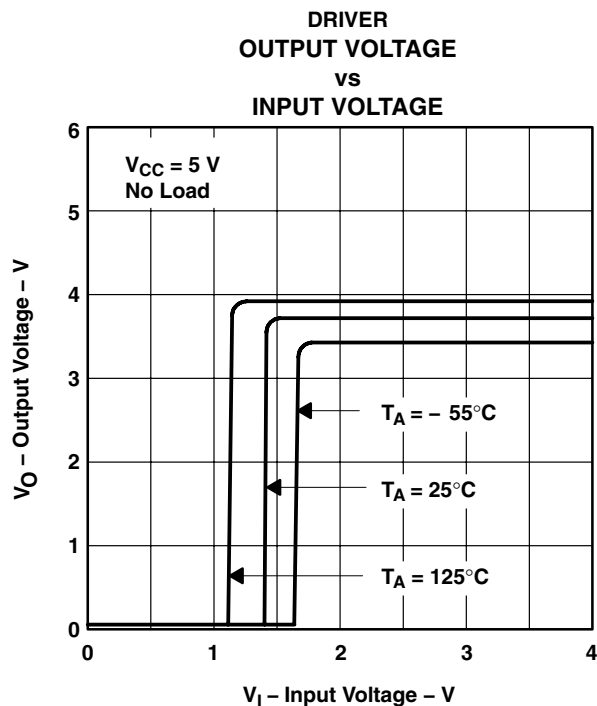

Figure 2

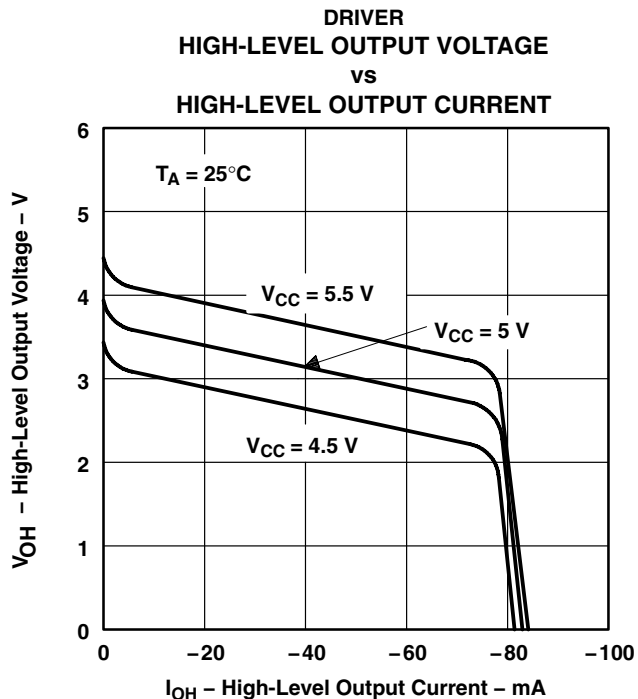

Figure 3

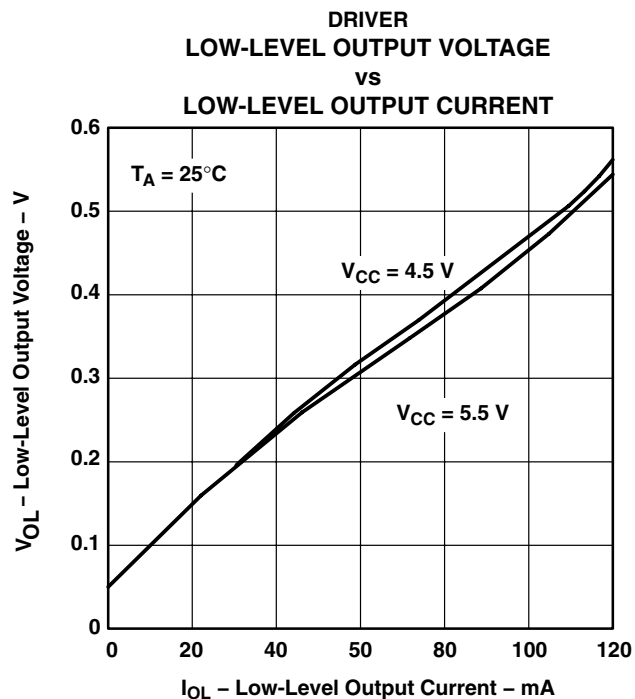

Figure 4

† Operation of the device at these or any other conditions beyond those indicated under "recommended operating conditions" is not implied.



TYPICAL CHARACTERISTICS†

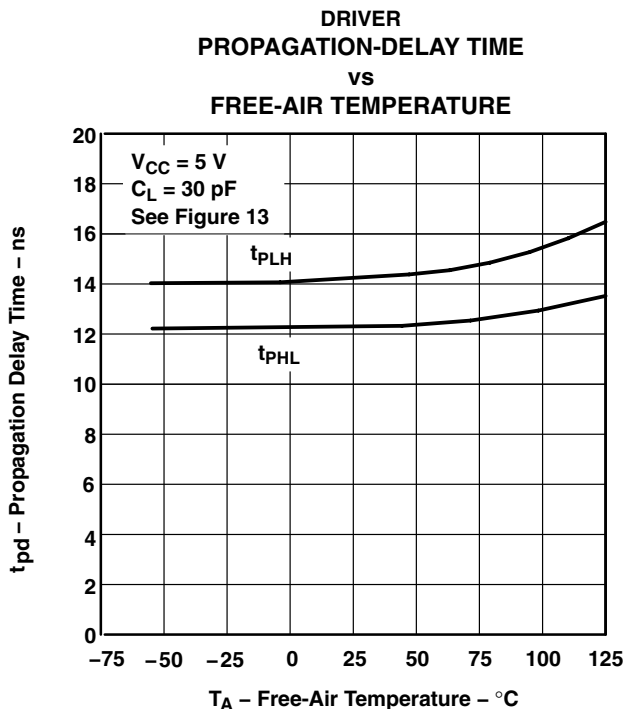
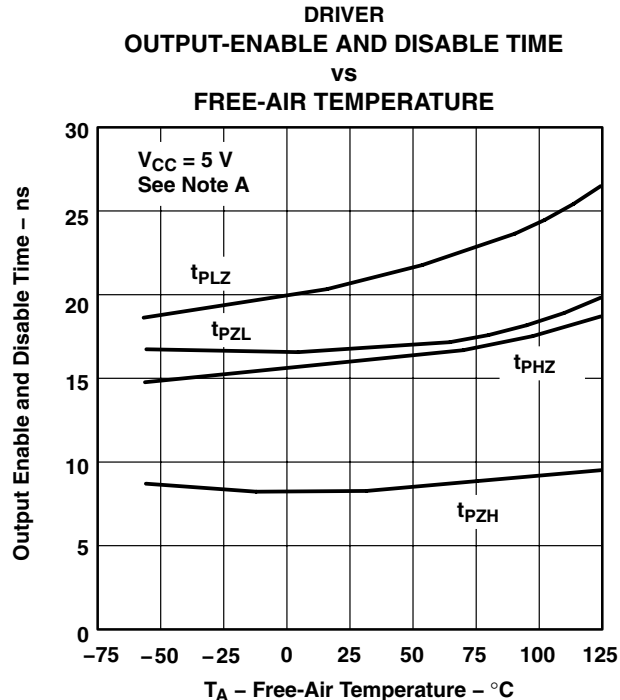

Figure 5



NOTE A: For t_{PZH} and t_{PHZ} : $R_L = 480 \Omega$, see Figure 14. For t_{PZL} and t_{PLZ} : $R_L = 250 \Omega$, see Figure 15.

Figure 6

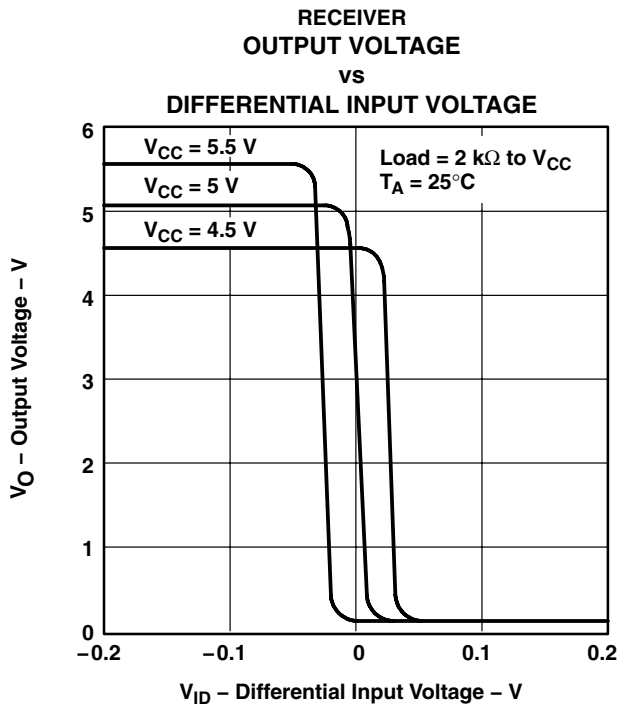

Figure 7

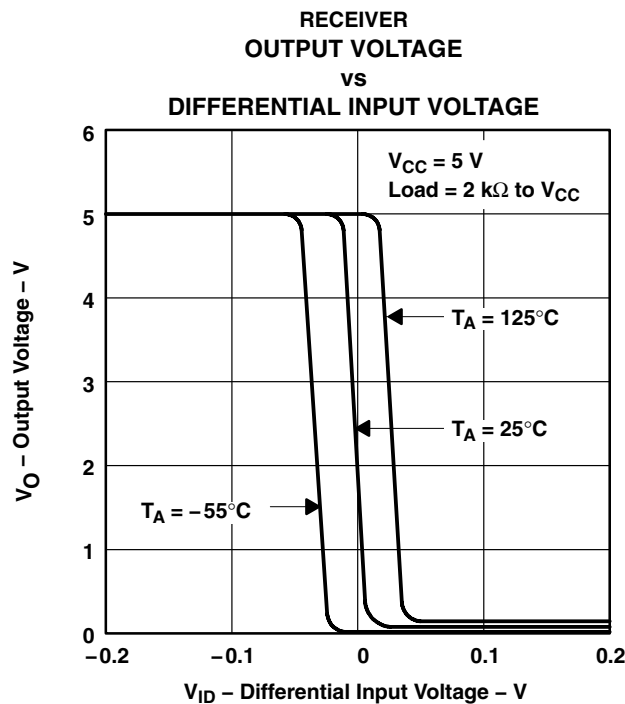

Figure 8

† Operation of the device at these or any other conditions beyond those indicated under "recommended operating conditions" is not implied.

SN55116, SN75116, SN75117, SN75118, SN75119 DIFFERENTIAL LINE TRANSCEIVERS

SLLS073D – MAY 1976 – REVISED MAY 1998

TYPICAL CHARACTERISTICS†

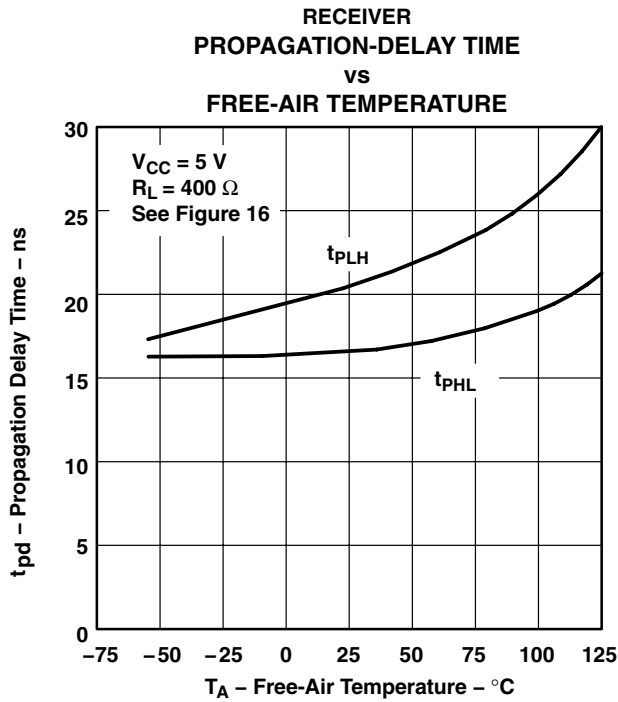
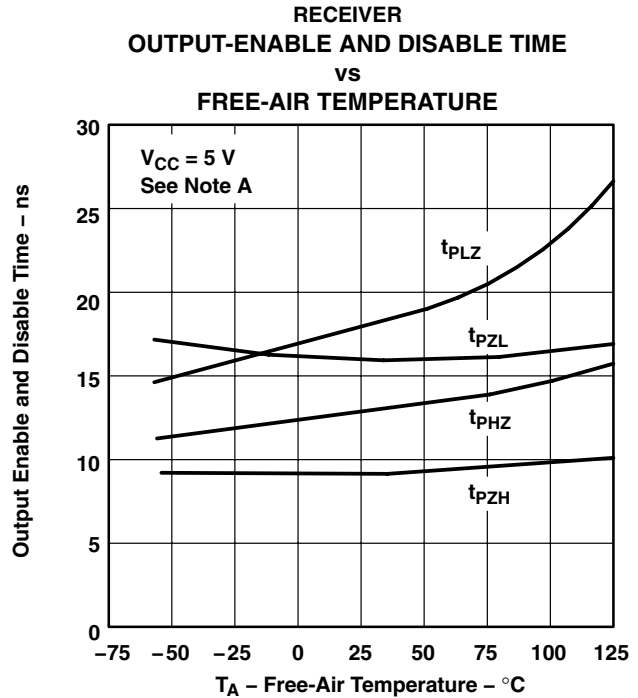

Figure 9



NOTE A: For t_{PZH} and t_{PHZ} : $R_L = 480\ \Omega$, see Figure 14. For t_{PZL} and t_{PLZ} : $R_L = 250\ \Omega$, see Figure 15.

Figure 10

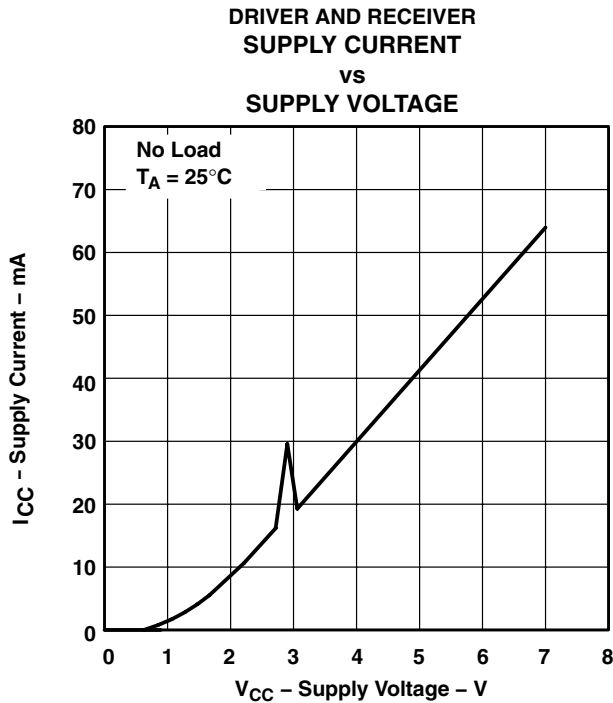

Figure 11

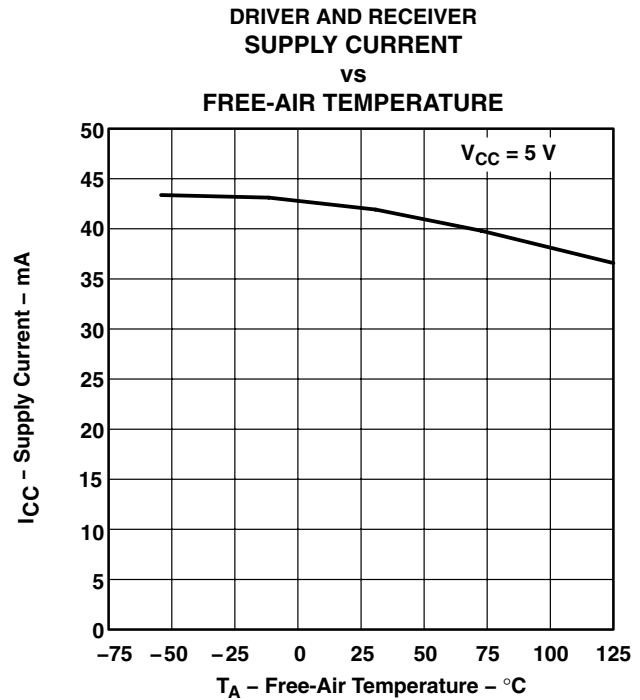

Figure 12

† Operation of the device at these or any other conditions beyond those indicated under "recommended operating conditions" is not implied.



PARAMETER MEASUREMENT INFORMATION

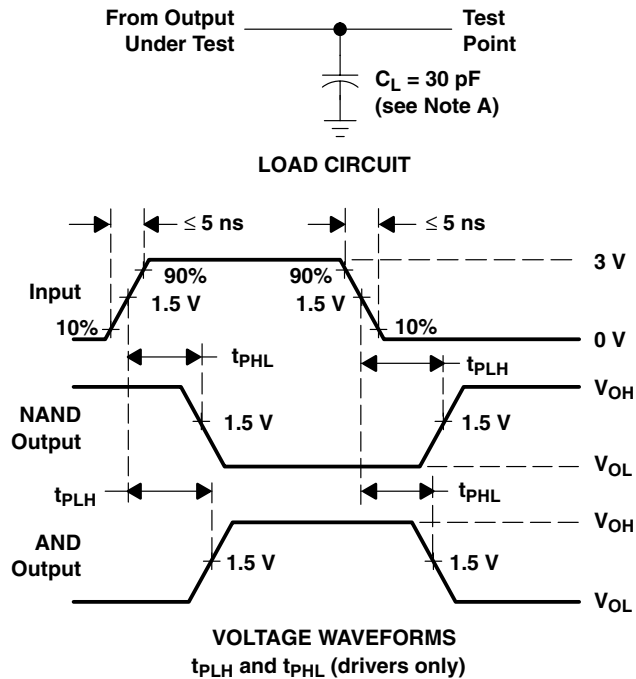

Figure 13

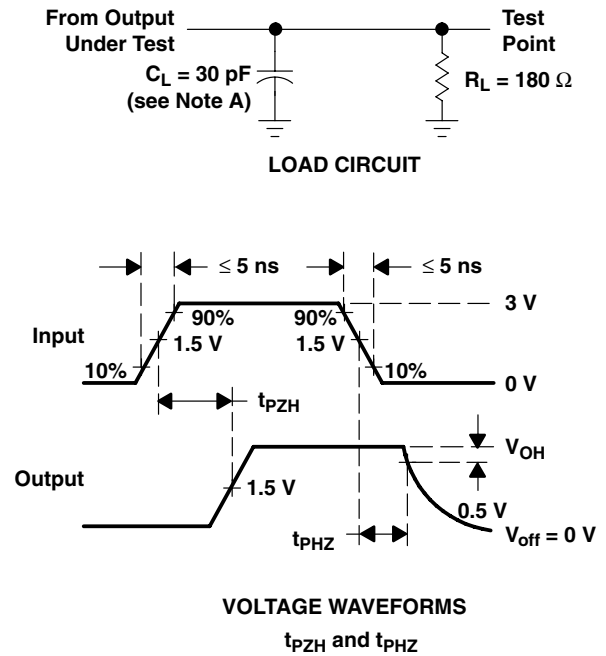

Figure 14

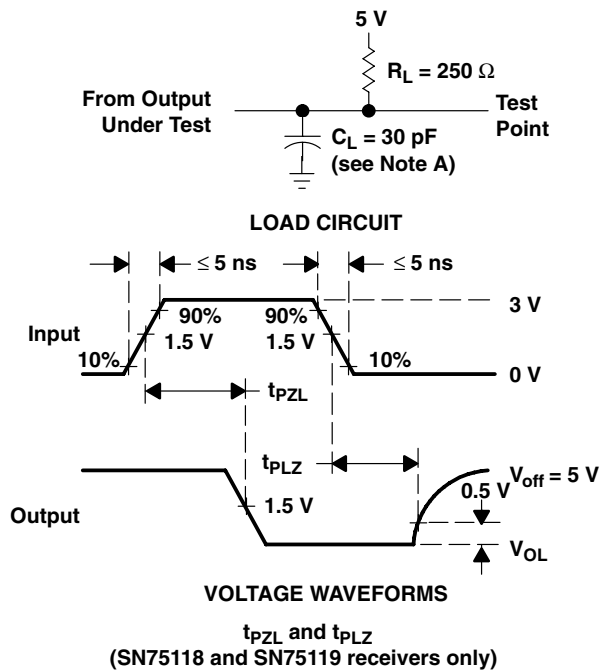

Figure 15

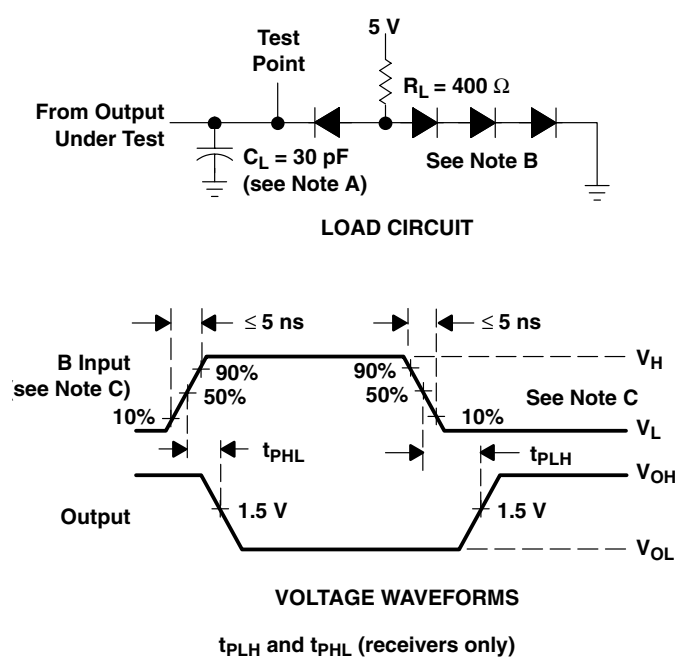

Figure 16

- NOTES: A. C_L includes probe and jig capacitance.
 B. All diodes are 1N3064 or equivalent.
 C. For '116 and SN75118, $V_H = 3\text{ V}$, $V_L = -3\text{ V}$, the A input is at 0 V.
 For SN75117 and SN75119, $V_H = 3\text{ V}$, $V_L = 0$, the A input is at 1.5 V.
 D. When testing the '116 and SN75118 receiver sections, the response-time control and the termination resistor pins are left open.

PACKAGING INFORMATION

Orderable Device	Status ⁽¹⁾	Package Type	Package Drawing	Pins	Package Qty	Eco Plan ⁽²⁾	Lead/ Ball Finish	MSL Peak Temp ⁽³⁾	Samples (Requires Login)
5962-88511012A	ACTIVE	LCCC	FK	20	1	TBD	POST-PLATE	N / A for Pkg Type	Purchase Samples
5962-8851101EA	ACTIVE	CDIP	J	16	1	TBD	A42	N / A for Pkg Type	Purchase Samples
SN55116J	OBSOLETE	CDIP	J	16		TBD	Call TI	Call TI	Samples Not Available
SN75116D	ACTIVE	SOIC	D	16	40	Green (RoHS & no Sb/Br)	CU NIPDAU	Level-1-260C-UNLIM	Purchase Samples
SN75116DE4	ACTIVE	SOIC	D	16	40	Green (RoHS & no Sb/Br)	CU NIPDAU	Level-1-260C-UNLIM	Purchase Samples
SN75116DG4	ACTIVE	SOIC	D	16	40	Green (RoHS & no Sb/Br)	CU NIPDAU	Level-1-260C-UNLIM	Purchase Samples
SN75116N	ACTIVE	PDIP	N	16	25	Pb-Free (RoHS)	CU NIPDAU	N / A for Pkg Type	Contact TI Distributor or Sales Office
SN75116NE4	ACTIVE	PDIP	N	16	25	Pb-Free (RoHS)	CU NIPDAU	N / A for Pkg Type	Contact TI Distributor or Sales Office
SN75116NSR	ACTIVE	SO	NS	16	2000	Green (RoHS & no Sb/Br)	CU NIPDAU	Level-1-260C-UNLIM	Contact TI Distributor or Sales Office
SN75116NSRE4	ACTIVE	SO	NS	16	2000	Green (RoHS & no Sb/Br)	CU NIPDAU	Level-1-260C-UNLIM	Contact TI Distributor or Sales Office
SN75116NSRG4	ACTIVE	SO	NS	16	2000	Green (RoHS & no Sb/Br)	CU NIPDAU	Level-1-260C-UNLIM	Contact TI Distributor or Sales Office
SN75117D	OBSOLETE	SOIC	D	8		TBD	Call TI	Call TI	Samples Not Available
SN75117P	ACTIVE	PDIP	P	8	50	Pb-Free (RoHS)	CU NIPDAU	N / A for Pkg Type	Contact TI Distributor or Sales Office
SN75117PE4	ACTIVE	PDIP	P	8	50	Pb-Free (RoHS)	CU NIPDAU	N / A for Pkg Type	Contact TI Distributor or Sales Office
SN75118D	OBSOLETE	SOIC	D	16		TBD	Call TI	Call TI	Samples Not Available
SN75118N	ACTIVE	PDIP	N	16	25	Pb-Free (RoHS)	CU NIPDAU	N / A for Pkg Type	Contact TI Distributor or Sales Office
SN75118NE4	ACTIVE	PDIP	N	16	25	Pb-Free (RoHS)	CU NIPDAU	N / A for Pkg Type	Contact TI Distributor or Sales Office
SN75119D	ACTIVE	SOIC	D	8	75	Green (RoHS & no Sb/Br)	CU NIPDAU	Level-2-260C-1 YEAR	Purchase Samples
SN75119DE4	ACTIVE	SOIC	D	8	75	Green (RoHS & no Sb/Br)	CU NIPDAU	Level-2-260C-1 YEAR	Purchase Samples

Orderable Device	Status ⁽¹⁾	Package Type	Package Drawing	Pins	Package Qty	Eco Plan ⁽²⁾	Lead/ Ball Finish	MSL Peak Temp ⁽³⁾	Samples (Requires Login)
SN75119DG4	ACTIVE	SOIC	D	8	75	Green (RoHS & no Sb/Br)	CU NIPDAU	Level-2-260C-1 YEAR	Purchase Samples
SN75119DR	ACTIVE	SOIC	D	8	2500	Green (RoHS & no Sb/Br)	CU NIPDAU	Level-2-260C-1 YEAR	Purchase Samples
SN75119DRE4	ACTIVE	SOIC	D	8	2500	Green (RoHS & no Sb/Br)	CU NIPDAU	Level-2-260C-1 YEAR	Purchase Samples
SN75119DRG4	ACTIVE	SOIC	D	8	2500	Green (RoHS & no Sb/Br)	CU NIPDAU	Level-2-260C-1 YEAR	Purchase Samples
SN75119P	ACTIVE	PDIP	P	8	50	Pb-Free (RoHS)	CU NIPDAU	N / A for Pkg Type	Contact TI Distributor or Sales Office
SN75119PE4	ACTIVE	PDIP	P	8	50	Pb-Free (RoHS)	CU NIPDAU	N / A for Pkg Type	Contact TI Distributor or Sales Office
SNJ55116FK	ACTIVE	LCCC	FK	20	1	TBD	POST-PLATE	N / A for Pkg Type	Contact TI Distributor or Sales Office
SNJ55116J	ACTIVE	CDIP	J	16	1	TBD	A42	N / A for Pkg Type	Contact TI Distributor or Sales Office

⁽¹⁾ The marketing status values are defined as follows:

ACTIVE: Product device recommended for new designs.

LIFEBUY: TI has announced that the device will be discontinued, and a lifetime-buy period is in effect.

NRND: Not recommended for new designs. Device is in production to support existing customers, but TI does not recommend using this part in a new design.

PREVIEW: Device has been announced but is not in production. Samples may or may not be available.

OBSELETE: TI has discontinued the production of the device.

⁽²⁾ Eco Plan - The planned eco-friendly classification: Pb-Free (RoHS), Pb-Free (RoHS Exempt), or Green (RoHS & no Sb/Br) - please check <http://www.ti.com/productcontent> for the latest availability information and additional product content details.

TBD: The Pb-Free/Green conversion plan has not been defined.

Pb-Free (RoHS): TI's terms "Lead-Free" or "Pb-Free" mean semiconductor products that are compatible with the current RoHS requirements for all 6 substances, including the requirement that lead not exceed 0.1% by weight in homogeneous materials. Where designed to be soldered at high temperatures, TI Pb-Free products are suitable for use in specified lead-free processes.

Pb-Free (RoHS Exempt): This component has a RoHS exemption for either 1) lead-based flip-chip solder bumps used between the die and package, or 2) lead-based die adhesive used between the die and leadframe. The component is otherwise considered Pb-Free (RoHS compatible) as defined above.

Green (RoHS & no Sb/Br): TI defines "Green" to mean Pb-Free (RoHS compatible), and free of Bromine (Br) and Antimony (Sb) based flame retardants (Br or Sb do not exceed 0.1% by weight in homogeneous material)

⁽³⁾ MSL, Peak Temp. -- The Moisture Sensitivity Level rating according to the JEDEC industry standard classifications, and peak solder temperature.

Important Information and Disclaimer: The information provided on this page represents TI's knowledge and belief as of the date that it is provided. TI bases its knowledge and belief on information provided by third parties, and makes no representation or warranty as to the accuracy of such information. Efforts are underway to better integrate information from third parties. TI has taken and

continues to take reasonable steps to provide representative and accurate information but may not have conducted destructive testing or chemical analysis on incoming materials and chemicals. TI and TI suppliers consider certain information to be proprietary, and thus CAS numbers and other limited information may not be available for release.

In no event shall TI's liability arising out of such information exceed the total purchase price of the TI part(s) at issue in this document sold by TI to Customer on an annual basis.

OTHER QUALIFIED VERSIONS OF SN55116, SN75116 :

- Catalog: [SN75116](#)
- Military: [SN55116](#)

NOTE: Qualified Version Definitions:

- Catalog - TI's standard catalog product
- Military - QML certified for Military and Defense Applications

TAPE AND REEL INFORMATION



QUADRANT ASSIGNMENTS FOR PIN 1 ORIENTATION IN TAPE



*All dimensions are nominal

Device	Package Type	Package Drawing	Pins	SPQ	Reel Diameter (mm)	Reel Width W1 (mm)	A0 (mm)	B0 (mm)	K0 (mm)	P1 (mm)	W (mm)	Pin1 Quadrant
SN75116NSR	SO	NS	16	2000	330.0	16.4	8.2	10.5	2.5	12.0	16.0	Q1
SN75119DR	SOIC	D	8	2500	330.0	12.4	6.4	5.2	2.1	8.0	12.0	Q1

TAPE AND REEL BOX DIMENSIONS



*All dimensions are nominal

Device	Package Type	Package Drawing	Pins	SPQ	Length (mm)	Width (mm)	Height (mm)
SN75116NSR	SO	NS	16	2000	346.0	346.0	33.0
SN75119DR	SOIC	D	8	2500	340.5	338.1	20.6

J (R-GDIP-T**)

14 LEADS SHOWN

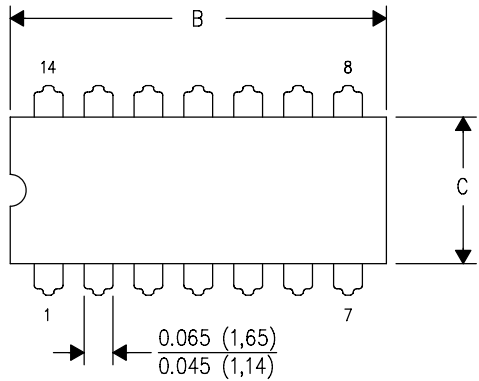
CERAMIC DUAL IN-LINE PACKAGE



DIM \ PINS **	14	16	18	20
A	0.300 (7,62) BSC	0.300 (7,62) BSC	0.300 (7,62) BSC	0.300 (7,62) BSC
B MAX	0.785 (19,94)	.840 (21,34)	0.960 (24,38)	1.060 (26,92)
B MIN	—	—	—	—
C MAX	0.300 (7,62)	0.300 (7,62)	0.310 (7,87)	0.300 (7,62)
C MIN	0.245 (6,22)	0.245 (6,22)	0.220 (5,59)	0.245 (6,22)

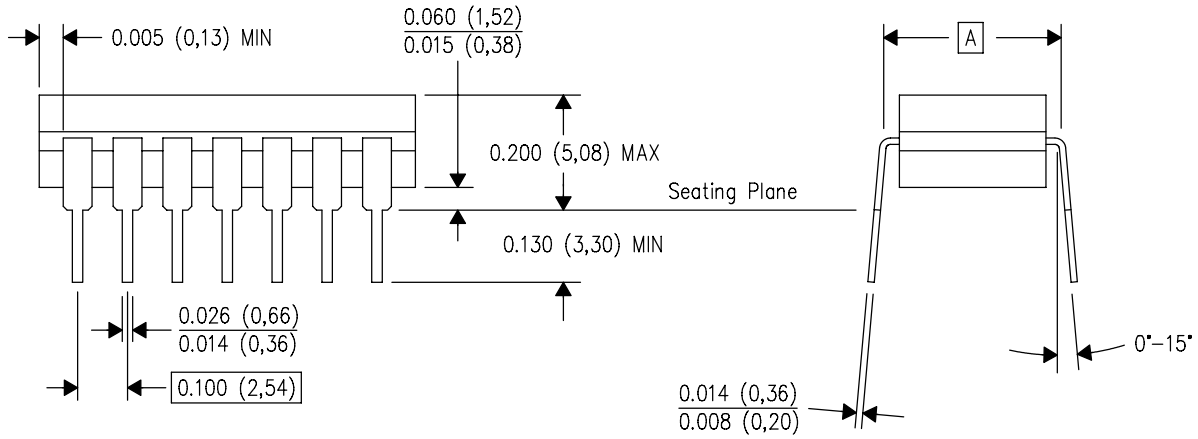

4040083/F 03/03

- NOTES:
- A. All linear dimensions are in inches (millimeters).
 - B. This drawing is subject to change without notice.
 - C. This package is hermetically sealed with a ceramic lid using glass frit.
 - D. Index point is provided on cap for terminal identification only on press ceramic glass frit seal only.
 - E. Falls within MIL STD 1835 GDIP1-T14, GDIP1-T16, GDIP1-T18 and GDIP1-T20.

FK (S-CQCC-N**)

LEADLESS CERAMIC CHIP CARRIER

28 TERMINAL SHOWN



- NOTES:
- A. All linear dimensions are in inches (millimeters).
 - B. This drawing is subject to change without notice.
 - C. This package can be hermetically sealed with a metal lid.
 - D. The terminals are gold plated.
 - E. Falls within JEDEC MS-004

P (R-PDIP-T8)

PLASTIC DUAL-IN-LINE PACKAGE



- NOTES:
- A. All linear dimensions are in inches (millimeters).
 - B. This drawing is subject to change without notice.
 - C. Falls within JEDEC MS-001 variation BA.

N (R-PDIP-T**)

PLASTIC DUAL-IN-LINE PACKAGE

16 PINS SHOWN





- NOTES:
- A. All linear dimensions are in inches (millimeters).
 - B. This drawing is subject to change without notice.
 - Falls within JEDEC MS-001, except 18 and 20 pin minimum body length (Dim A).
 - The 20 pin end lead shoulder width is a vendor option, either half or full width.

D (R-PDSO-G16)

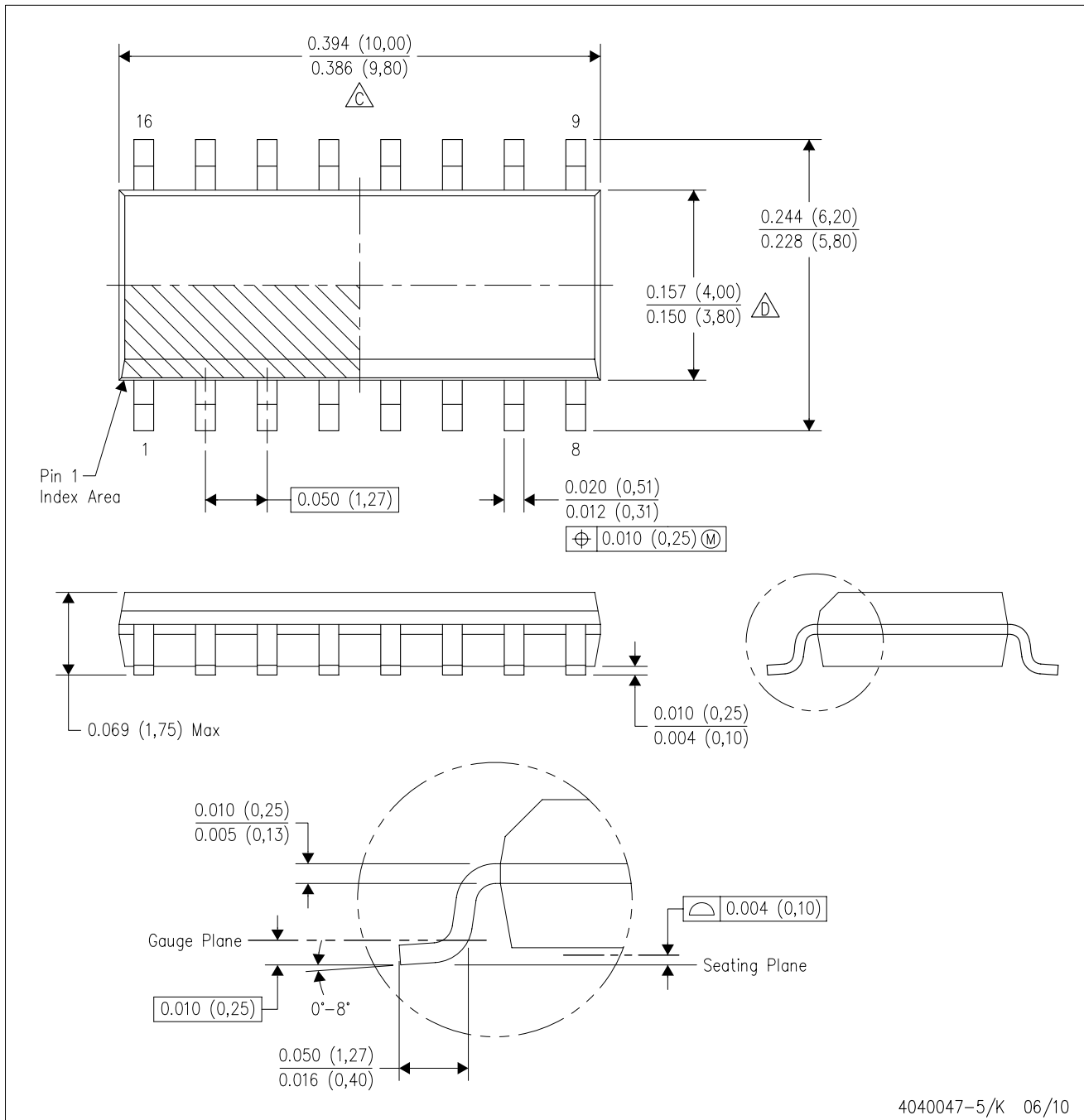
PLASTIC SMALL-OUTLINE PACKAGE



4040047-5/K 06/10

- NOTES:
- A. All linear dimensions are in inches (millimeters).
 - B. This drawing is subject to change without notice.
 -  C. Body length does not include mold flash, protrusions, or gate burrs. Mold flash, protrusions, or gate burrs shall not exceed .006 (0,15) per end.
 -  D. Body width does not include interlead flash. Interlead flash shall not exceed .017 (0,43) per side.
 - E. Reference JEDEC MS-012 variation AC.

D(R-PDSO-G16)

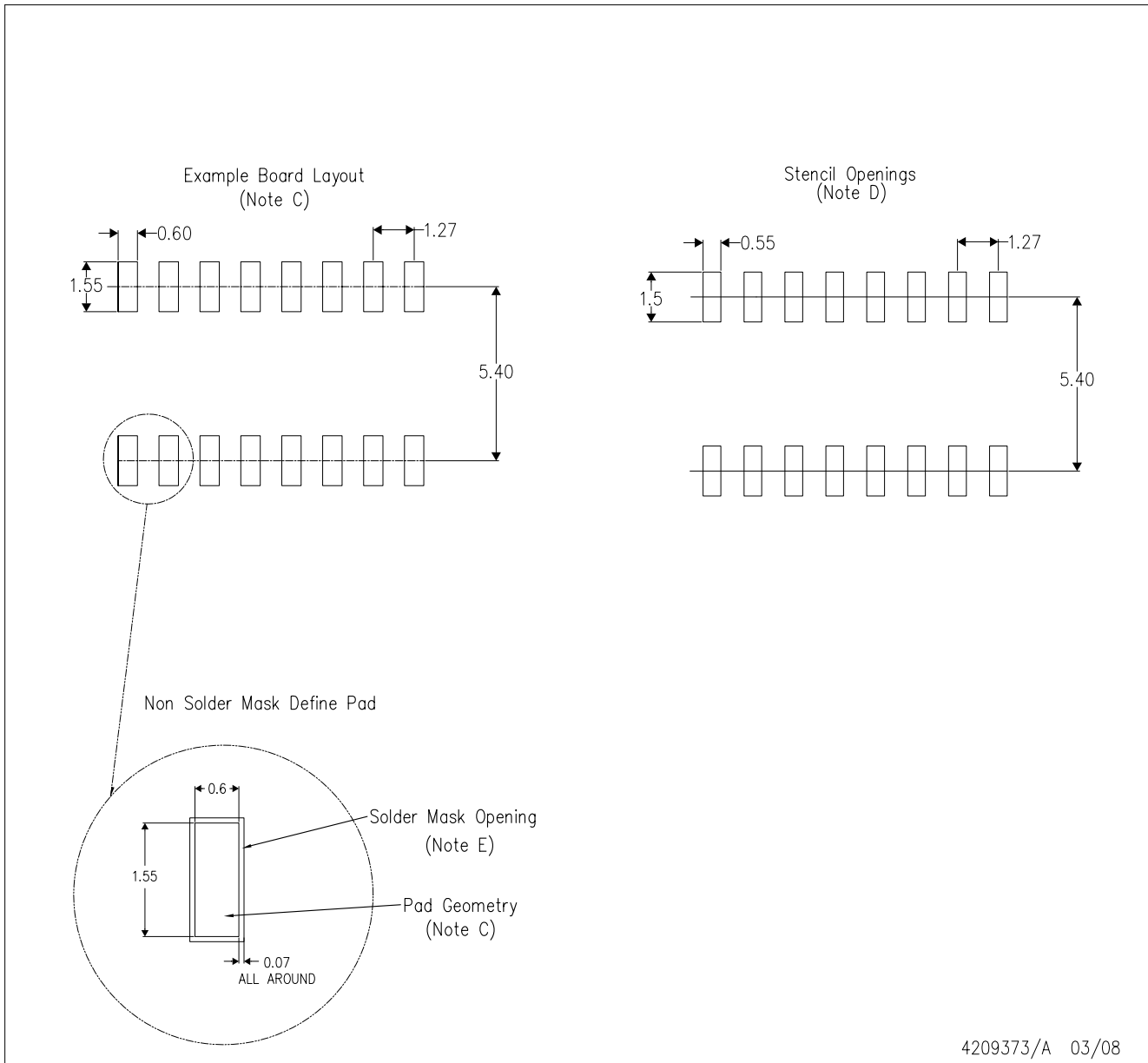

- NOTES:
- A. All linear dimensions are in millimeters.
 - B. This drawing is subject to change without notice.
 - C. Refer to IPC7351 for alternate board design.
 - D. Laser cutting apertures with trapezoidal walls and also rounding corners will offer better paste release. Customers should contact their board assembly site for stencil design recommendations. Refer to IPC-7525
 - E. Customers should contact their board fabrication site for solder mask tolerances between and around signal pads.

D (R-PDSO-G8)

PLASTIC SMALL-OUTLINE PACKAGE

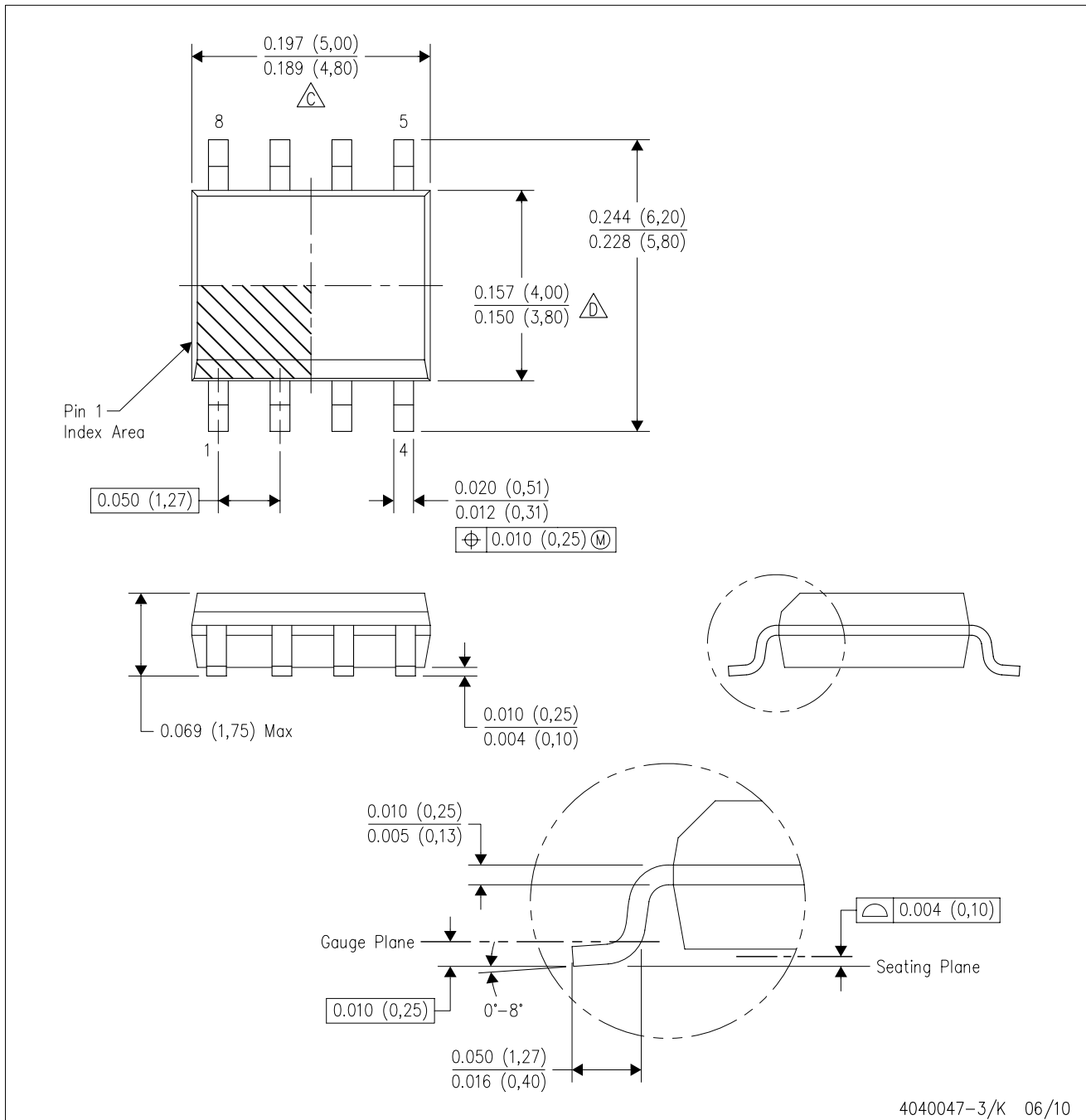

- NOTES:
- A. All linear dimensions are in inches (millimeters).
 - B. This drawing is subject to change without notice.
 - Body length does not include mold flash, protrusions, or gate burrs. Mold flash, protrusions, or gate burrs shall not exceed .006 (0,15) per end.
 - Body width does not include interlead flash. Interlead flash shall not exceed .017 (0,43) per side.
 - E. Reference JEDEC MS-012 variation AA.

MECHANICAL DATA

NS (R-PDSO-G**)

PLASTIC SMALL-OUTLINE PACKAGE

14-PINS SHOWN



- NOTES:
- A. All linear dimensions are in millimeters.
 - B. This drawing is subject to change without notice.
 - C. Body dimensions do not include mold flash or protrusion, not to exceed 0,15.

IMPORTANT NOTICE

Texas Instruments Incorporated and its subsidiaries (TI) reserve the right to make corrections, modifications, enhancements, improvements, and other changes to its products and services at any time and to discontinue any product or service without notice. Customers should obtain the latest relevant information before placing orders and should verify that such information is current and complete. All products are sold subject to TI's terms and conditions of sale supplied at the time of order acknowledgment.

TI warrants performance of its hardware products to the specifications applicable at the time of sale in accordance with TI's standard warranty. Testing and other quality control techniques are used to the extent TI deems necessary to support this warranty. Except where mandated by government requirements, testing of all parameters of each product is not necessarily performed.

TI assumes no liability for applications assistance or customer product design. Customers are responsible for their products and applications using TI components. To minimize the risks associated with customer products and applications, customers should provide adequate design and operating safeguards.

TI does not warrant or represent that any license, either express or implied, is granted under any TI patent right, copyright, mask work right, or other TI intellectual property right relating to any combination, machine, or process in which TI products or services are used. Information published by TI regarding third-party products or services does not constitute a license from TI to use such products or services or a warranty or endorsement thereof. Use of such information may require a license from a third party under the patents or other intellectual property of the third party, or a license from TI under the patents or other intellectual property of TI.

Reproduction of TI information in TI data books or data sheets is permissible only if reproduction is without alteration and is accompanied by all associated warranties, conditions, limitations, and notices. Reproduction of this information with alteration is an unfair and deceptive business practice. TI is not responsible or liable for such altered documentation. Information of third parties may be subject to additional restrictions.

Resale of TI products or services with statements different from or beyond the parameters stated by TI for that product or service voids all express and any implied warranties for the associated TI product or service and is an unfair and deceptive business practice. TI is not responsible or liable for any such statements.

TI products are not authorized for use in safety-critical applications (such as life support) where a failure of the TI product would reasonably be expected to cause severe personal injury or death, unless officers of the parties have executed an agreement specifically governing such use. Buyers represent that they have all necessary expertise in the safety and regulatory ramifications of their applications, and acknowledge and agree that they are solely responsible for all legal, regulatory and safety-related requirements concerning their products and any use of TI products in such safety-critical applications, notwithstanding any applications-related information or support that may be provided by TI. Further, Buyers must fully indemnify TI and its representatives against any damages arising out of the use of TI products in such safety-critical applications.

TI products are neither designed nor intended for use in military/aerospace applications or environments unless the TI products are specifically designated by TI as military-grade or "enhanced plastic." Only products designated by TI as military-grade meet military specifications. Buyers acknowledge and agree that any such use of TI products which TI has not designated as military-grade is solely at the Buyer's risk, and that they are solely responsible for compliance with all legal and regulatory requirements in connection with such use.

TI products are neither designed nor intended for use in automotive applications or environments unless the specific TI products are designated by TI as compliant with ISO/TS 16949 requirements. Buyers acknowledge and agree that, if they use any non-designated products in automotive applications, TI will not be responsible for any failure to meet such requirements.

Following are URLs where you can obtain information on other Texas Instruments products and application solutions:

Products		Applications	
Amplifiers	amplifier.ti.com	Audio	www.ti.com/audio
Data Converters	dataconverter.ti.com	Automotive	www.ti.com/automotive
DLP® Products	www.dlp.com	Communications and Telecom	www.ti.com/communications
DSP	dsp.ti.com	Computers and Peripherals	www.ti.com/computers
Clocks and Timers	www.ti.com/clocks	Consumer Electronics	www.ti.com/consumer-apps
Interface	interface.ti.com	Energy	www.ti.com/energy
Logic	logic.ti.com	Industrial	www.ti.com/industrial
Power Mgmt	power.ti.com	Medical	www.ti.com/medical
Microcontrollers	microcontroller.ti.com	Security	www.ti.com/security
RFID	www.ti-rfid.com	Space, Avionics & Defense	www.ti.com/space-avionics-defense
RF/IF and ZigBee® Solutions	www.ti.com/lprf	Video and Imaging	www.ti.com/video
		Wireless	www.ti.com/wireless-apps

Mailing Address: Texas Instruments, Post Office Box 655303, Dallas, Texas 75265
Copyright © 2010, Texas Instruments Incorporated