

Modular Jack Connectors for High-Speed LAN Transmission

TM21R Series

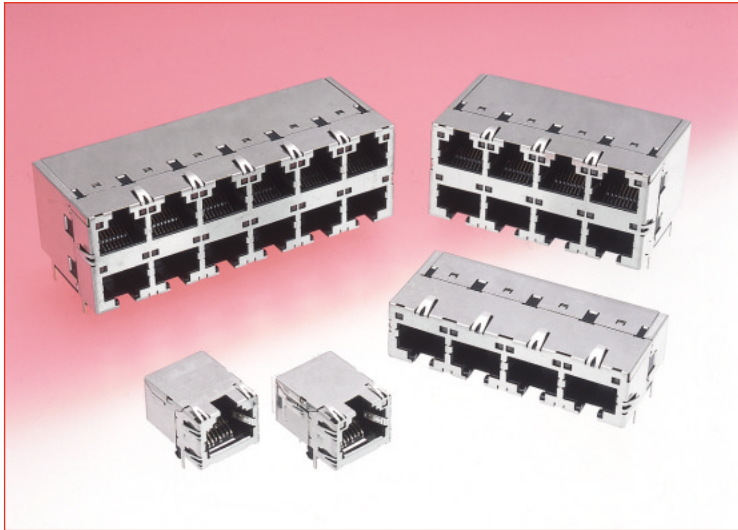

■ Features

1. Supports High-Speed LAN Transmission

Meets requirements of TIA/EIA-568-B data wiring standard. Single port configuration meeting CAT5e and multiple port configuration meeting CAT5 transmission performance.

As such, these products fully support Gigabit Ethernet (1000BASE-T) and Fast Ethernet (100BASE-TX) high-speed LAN transmission.

2. Built-in Optical Indicators

Optical indicators are integral part of the connectors saving space on customer's board.

Compared with LED type indicators, they do not emit any electrical noise.

3. EMI protection

Metal shield covers the outer surfaces of the connectors assuring complete protection against electromagnetic interference.

Built-in multiple shield and ground contacts assure reliable connection with the mounting panel as well as with the mating connector.

4. FCC Standards

Meets requirements of FCC Title 47, Part 68, Subpart F.

■ Applications

Telecom Hubs, Routers, Bridges and ATM Transmission Equipment, Ethernet Switches and Networking Equipment, Test and Measurement Equipment, Medical Diagnostic Equipment.

Built-in Optical Indicators

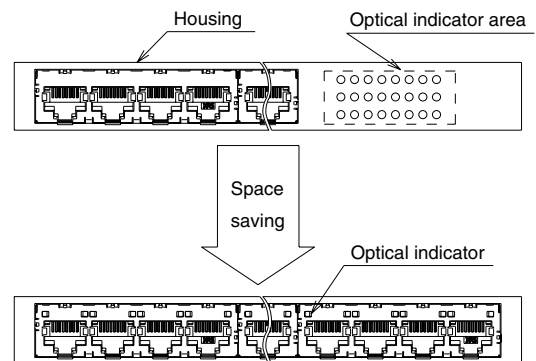
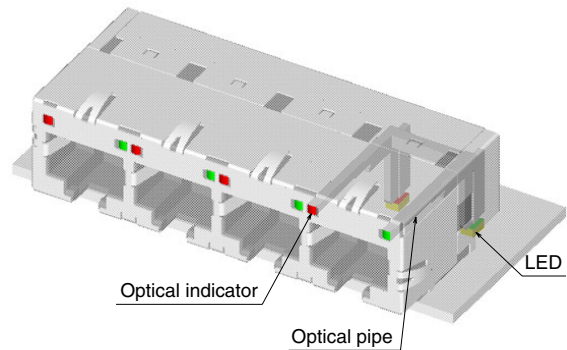

One additional TM21 multi-port jack can be mounted in the space previously occupied by LEDs.

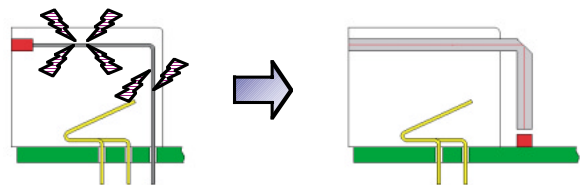

Built-in LED type
(Possibility of
electromagnetic noise
emission and
interference.)

Built-in Optical pipe
type
(No electromagnetic
noise emission.)

■Product Specifications

Ratings	Current rating 1A	Operating temperature range-25°C to +80°C (Note)
	Voltage rating 125 V AC	

Item	Specification	Conditions
1.Insulation resistance	100 M ohms min	100 V DC
2.Dielectric Withstanding Voltage (between adjacent contacts)	No flashover or insulation breakdown	500 V AC / one minute
3.Withstanding voltage (between contact and shield)	No flashover or insulation breakdown	1500 V AC / one minute
4.Contact resistance	230 m ohms max.	100mA DC
5.Vibration	No electrical discontinuity of 5 ms or more Contact resistance: 250m ohms max.	Frequency: 10 to 55 Hz, single amplitude of 0.75 mm, 2 hours / 3 axis
6.Shock	No electrical discontinuity of 5ms or more Contact resistance: 250m ohms max.	Acceleration of 490 m/s ² , 11 ms duration, sine half-wave waveform, 3 cycles in each of the 3 axis
7.Durability (mating/unmating)	Contact resistance: 250m ohms max.	200 cycles
8.Temperature cycle	Contact resistance: 250 m ohms max. Insulation resistance: 100 M ohms min.	(Temperature: -55°C→+5°C to +35°C→+85°C→+5°C to +35°C Duration: 30 → 5 → 30 → 5 (Minutes) 5 cycles
9.Humidity	Contact resistance: 250 m ohms max. Insulation resistance: 1 M ohms min. (High humidity) Insulation resistance: 10 M ohms min. (Dry state)	500 hours at temperature of 40°C and humidity of 90% to 95%
10.Salt Spray	Contact resistance: 250 m ohms max.	Exposed to density 5% salt water for 48 hours

Note :Includes temperature rise caused by current flow.

■Materials

Part	Material	Finish	Remarks
Insulator	PBT	Color: Black	UL94V-0
Contact	Copper alloy	Contact area: Gold plating Termination area: Solder plating	—
Optical pipe	Poly carbonate	Color: Clear	—
Shield	Copper alloy	Tin plating	—

■Ordering information

●Jacks

TM21 R - 5 A - 32 32 D - LP

① ② ③ ④ ⑤ ⑥ ⑦ ⑧

① Series Name	TM21
② Connector type	R : Jack
③ Jack type number	5 : PCB Right-angle through hole type
④ Jack performance level code	A : CAT5 (Single row, multi-port) B : CAT5 (Double row, multi port) C : Supports CAT5e (Single port)
⑤ Jack opening code	8 : 8 contacts 32 : 8 contacts /4 ports 48 : 8 contact/6 ports
⑥ Number of inserted contacts	8 : 8 contact 32 : 8 contact inserted in 4 ports=32 contacts 48 : 8 contact inserted in 6 ports=48 contacts
⑦ Number of rows	Blank: Single row D: Double row
⑧ Optical pipe	LP: With optical pipe inserted Blank: Without optical pipe

■Modular Jack Connectors Supporting CAT5e

●Single Port With Built-in Optical Pipe

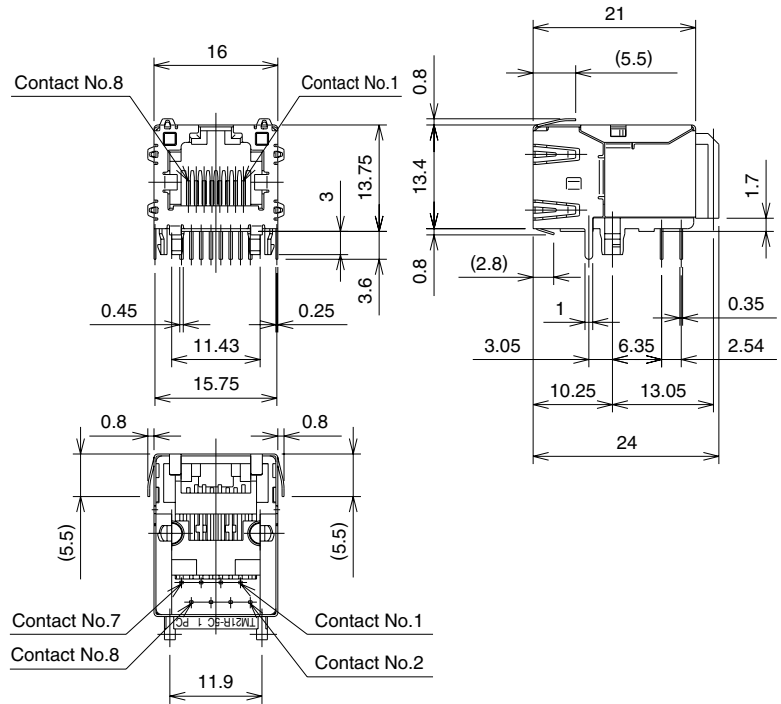
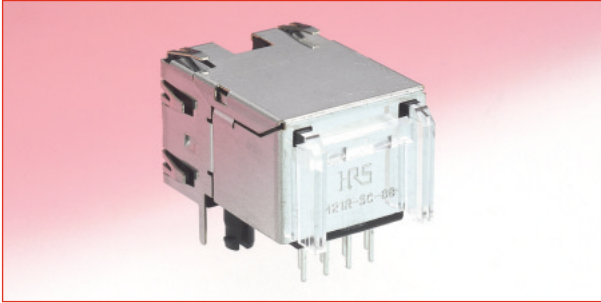
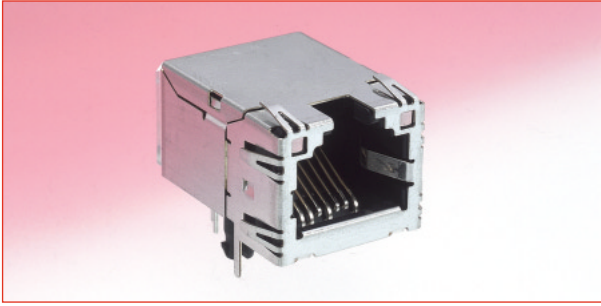

Part Number	CL No.
TM21R-5C-88-LP	222-2892-0

●Single Port Without Optical Pipe

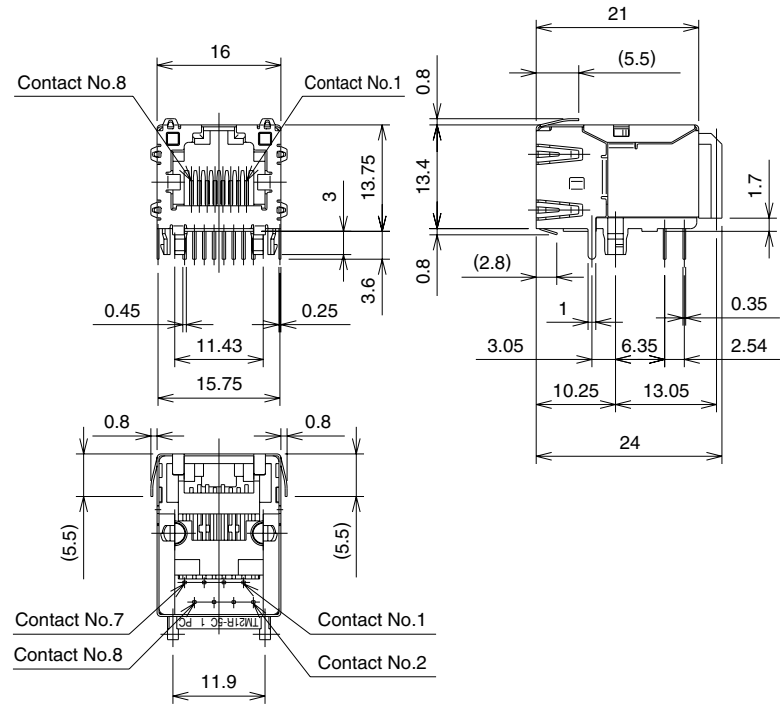
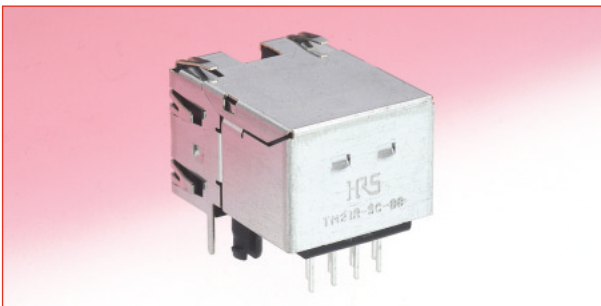
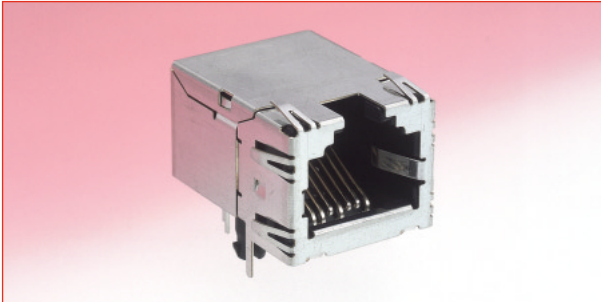

Part Number	CL No.
TM21R-5C-88	222-2893-2

◆ Recommended PCB mounting patterns

● With Built-in Optical Pipe

● Without Optical Pipe

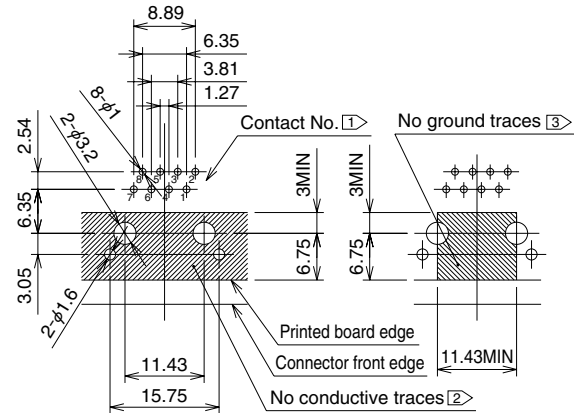
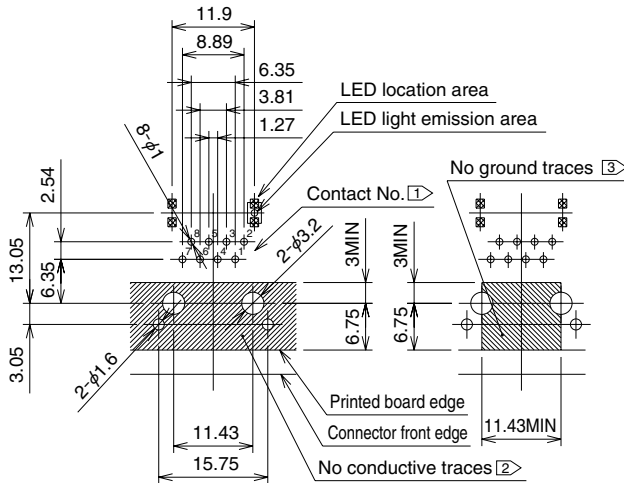

*Recommendations for PCB Design

- 1 The contact arrangement differs between the contact area side and Printed board side. (1,2,3,4,5,6,7,8 on the contact area side → 2,1,3,4,5,6,8,7 on the printed board side)
- 2 Areas indicated should be free of conductive traces.
- 3 Area indicated should be free of ground traces.
- 4 Recommended board thickness: 1.6mm.
- 5 To assure that the indicator light pipes operates correctly the LED's must be installed directly on the PCB, within recommended dimensions and with light emitting center in upward direction. Contact applicable manufacturer for LED specification.

1 PCB mounting pattern

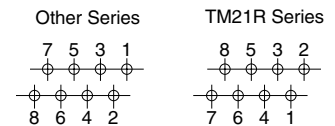

5 Suggested LEDs

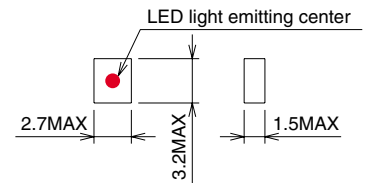

◆ Panel Cutout

● For Both Types, With and Without Built-in Optical Pipe

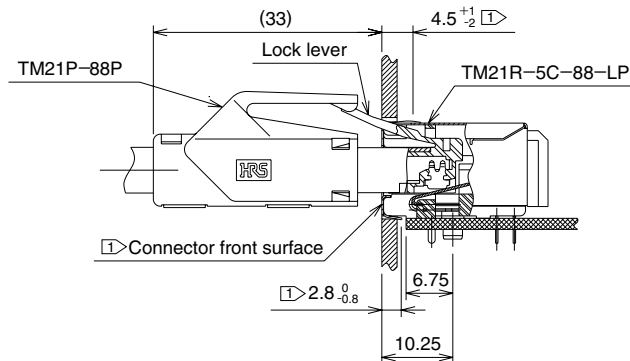
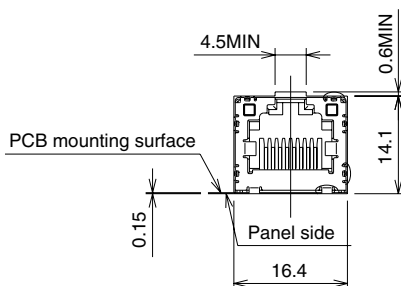

*Recommendations for Panel Design

- 1 The shield contacts should connect with the panel cut-out on all sides.

Modular Receptacles Supporting CAT5

Single row/ multiple ports, with Built-in Optical Pipe

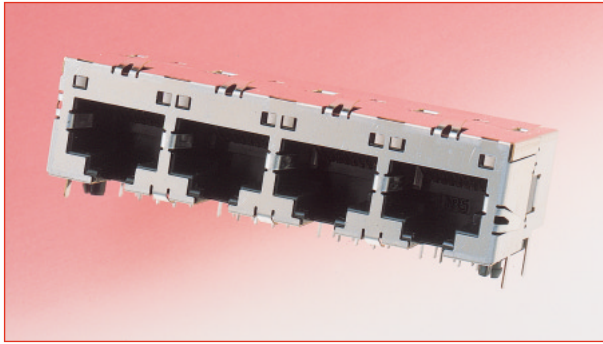

Part Number	CL No.
TM21R-5A-3232-LP	222-2873-5

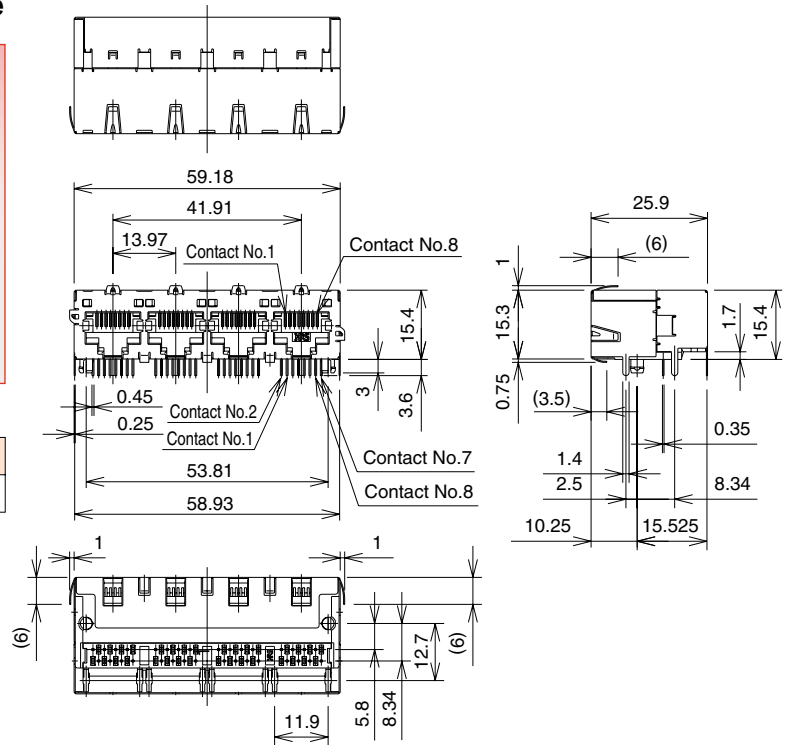

Recommended PCB mounting patterns

LED Mount Area Dimensions

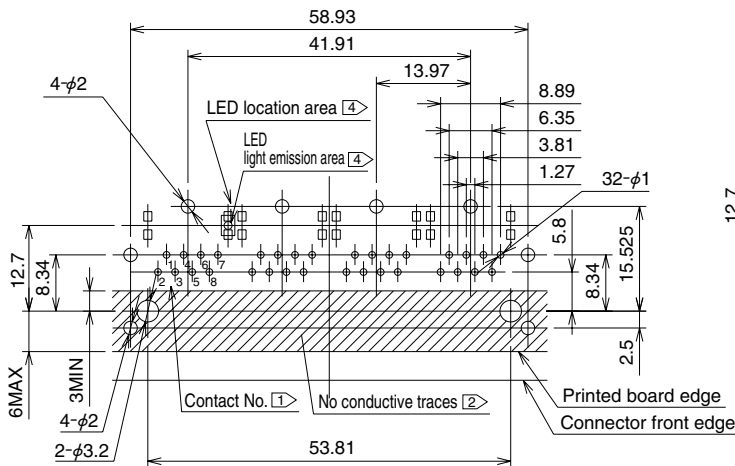

CL-220 Series

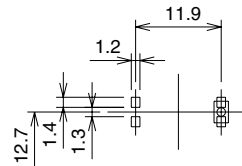

SML-010 Series

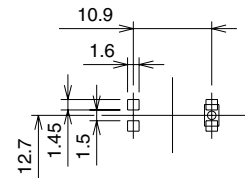

SML-020 Series

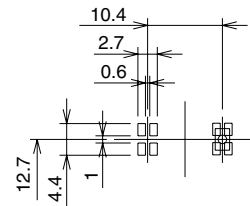

*Recommendations for PCB Design

- The contact arrangement differs between the contact area side and Printed board side. (1,2,3,4,5,6,7,8 on the contact area side → 2,1,3,4,5,6,8,7 on the printed board side)
- Areas indicated should be free of conductive traces.
- Recommended board thickness: 1.6mm.
- To assure that the indicator light pipe operates correctly the LED's must be installed directly on the PCB, within recommended dimensions and with light emitting center in upward direction. Contact applicable manufacturer for LED specification.

4 Suggested LEDs

Series Name	Manufacturer
CL-220	Citizen Electronics Co., Ltd.
SML-010	Rohm Co., LTD
SML-020	Rohm Co., LTD

1 PCB mounting pattern

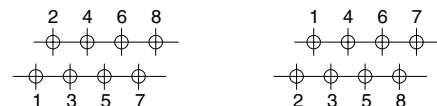

◆ Recommended Panel Cutout

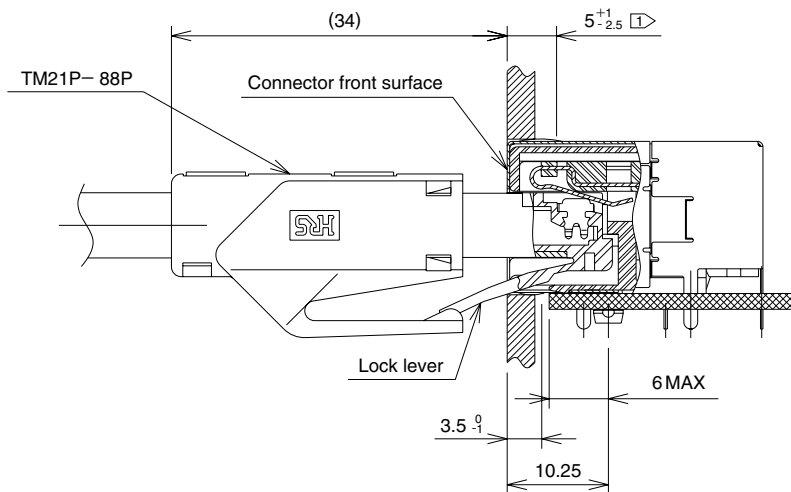
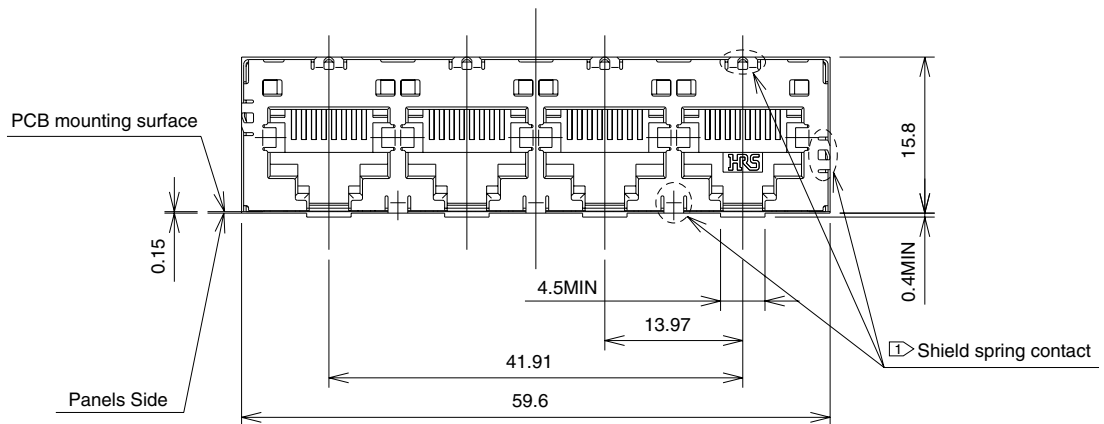

*Recommendations for Panel Design

- ① The shield contacts should connect with the panel cut-out on all sides.

◆ Panes Cutout

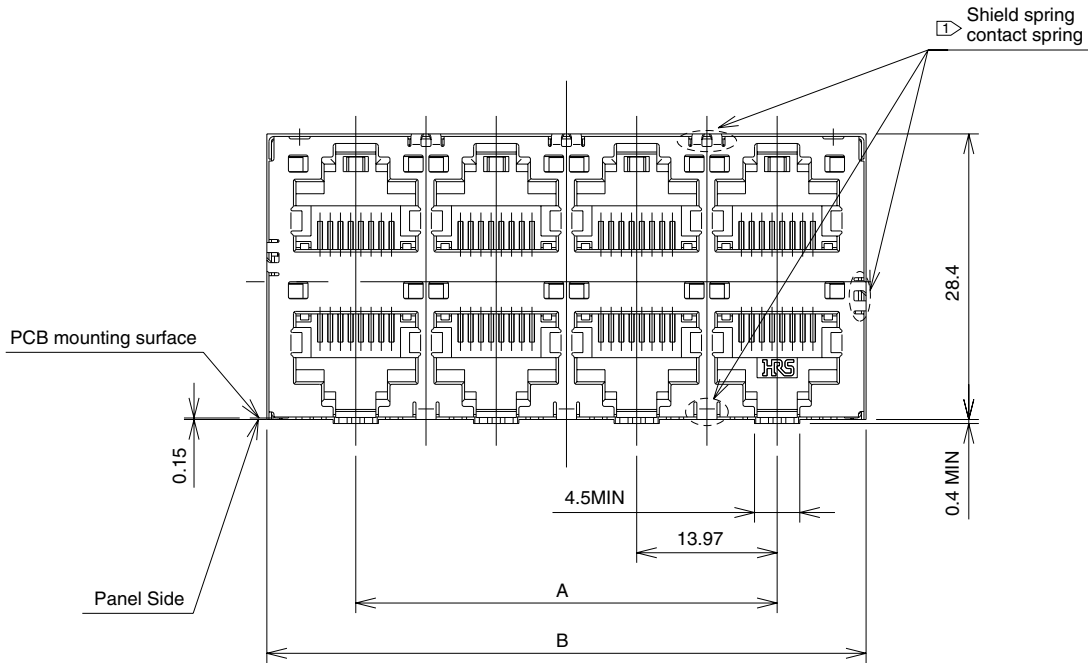

Part Number	CL No.	A	B
TM21R-5B-3232D-LP	222-2879-1	41.91	59.6
TM21R-5B-4848D-LP	222-2885-4	69.85	87.54

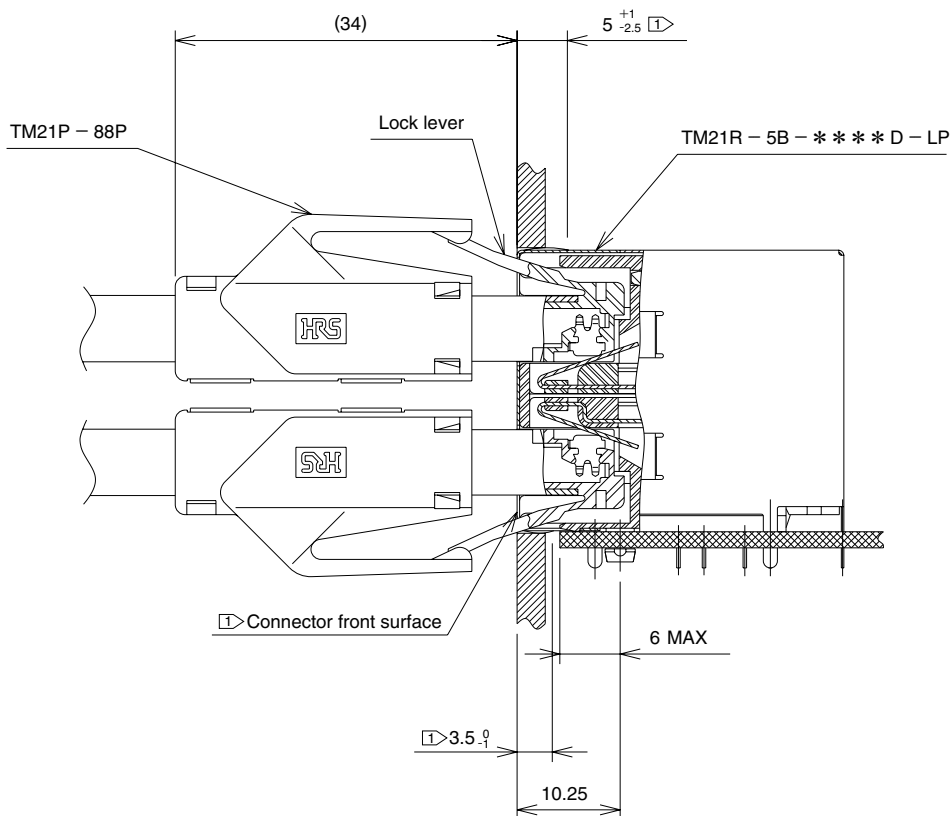

*Recommendations for Panel Design

1 The shield contacts should connect with the panel cut-out on all sides.

◆ Technical Documentation CAT5e Transmission Characteristics Data

Representative values of the various transmission characteristics data for fully mated receptacle (TM21R-5C-88-LP) and plug (TM21P-88P).

All plugs in the TM21R-5C Series that were manufactured based on the De-embedded method of the TIA/EIA-568-B.2 standard and meet performance requirements of CAT5e single transmission.

Note: These data are for the listed connector combination. Inquire with your Hirose Electric account representative about other combinations.

● Signal Attenuation

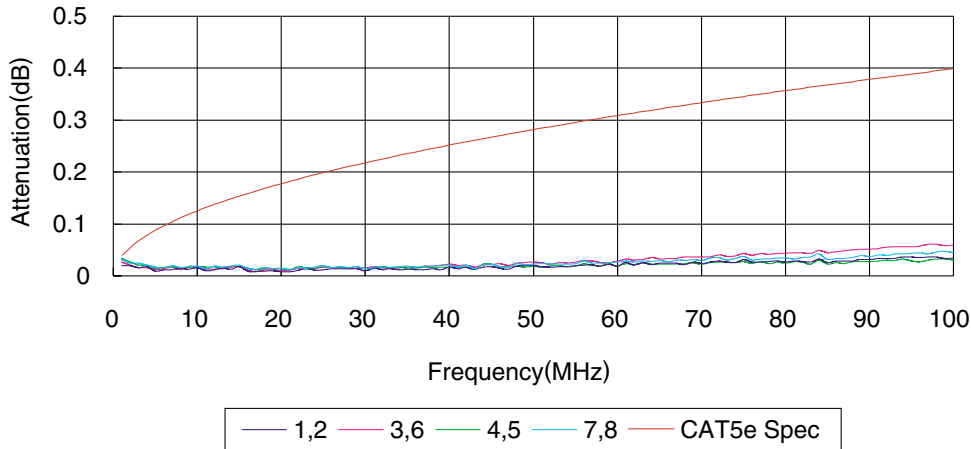

● Near-End Crosstalk (NEXT) Data

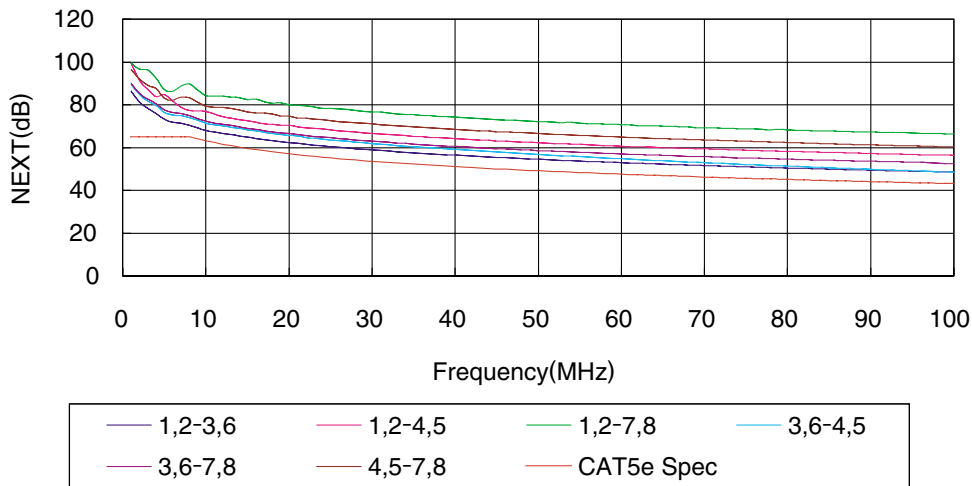

● Return Loss

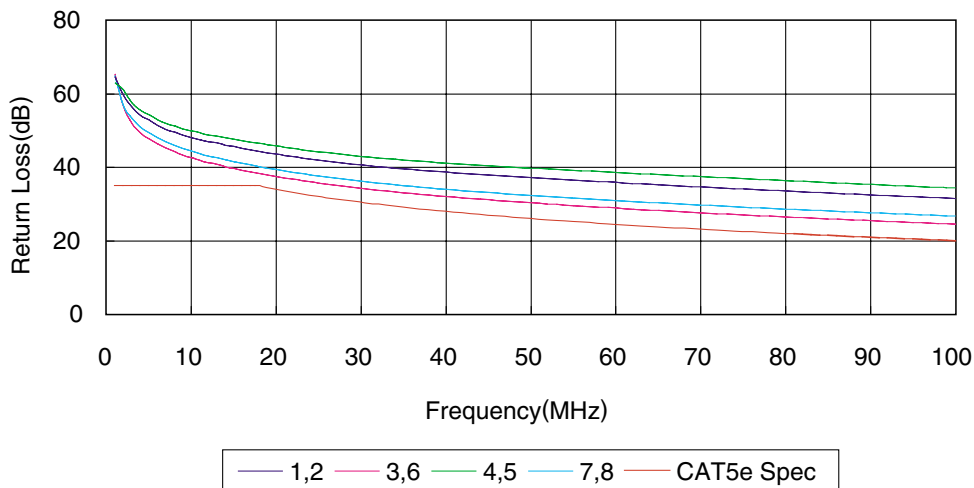

● Far-End Crosstalk (FEXT)

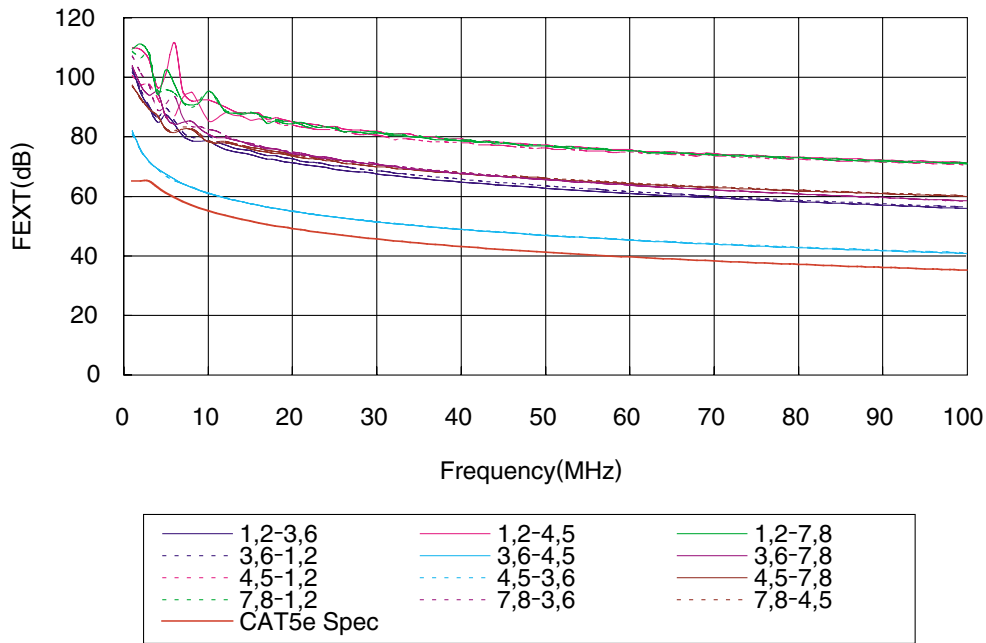

● Propagation Delay

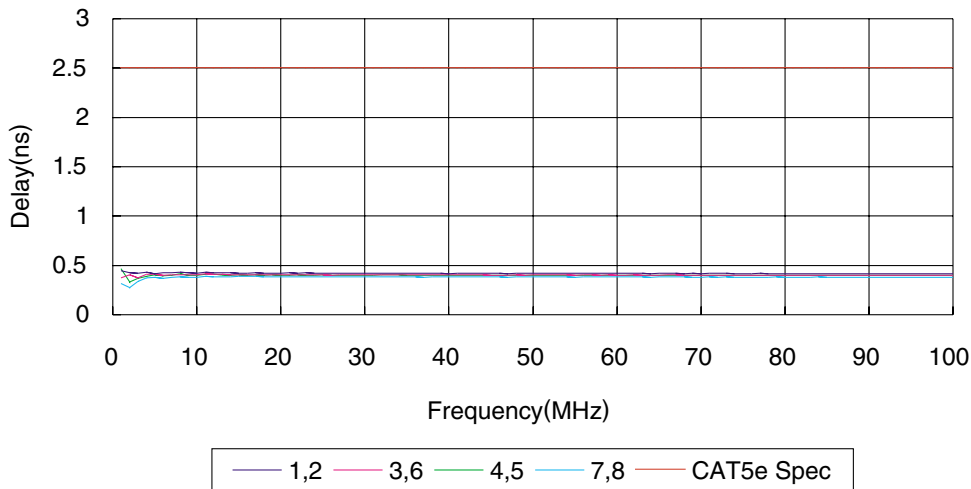

● Propagation Delay (Delay Skew)

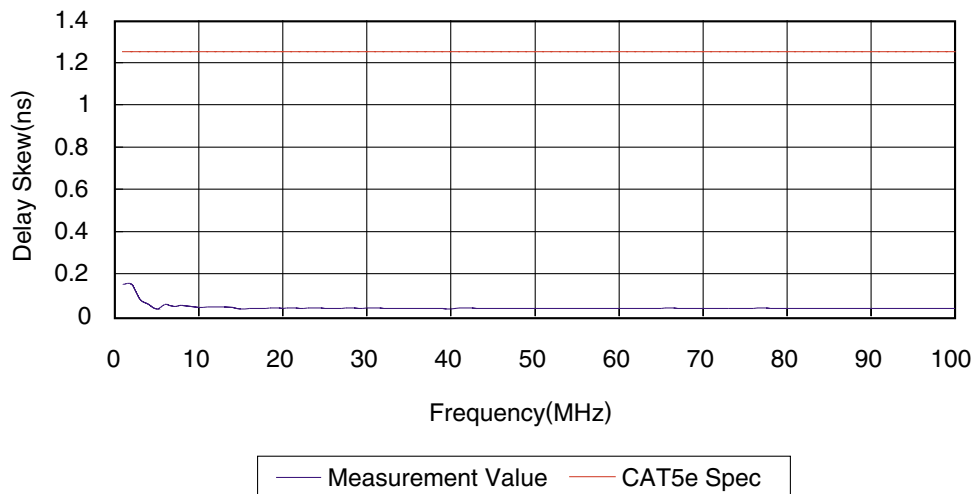

◆ Reference Documentation

● CAT6 Certification Received

Only the high quality plugs in the TM21R-5C Series (based on the De-embedded method of the TIA/EIA-568-B.2 standard) clear CAT6 single transmission performance. A certificate was issued by the GHMT, independent European testing company.



Certificate

Customer: Hirose Electric GmbH
Zeppelinstraße 42
D-73760 Ostfildern

Description: **HIROSE TM21R-5C-88**

Applied standards: TIA/EIA-568-B.2-1 (Addendum No.1 to TIA/EIA-568-B.2)
SP-3727 TIA/EIA Draft Standard (August 24, 2001 – Draft 9a)
Transmission Performance Specifications for 4-Pair 100Ω Category 6 Cabling

Comments: The test results which were determined in the course of the measurement refer to the submitted specimen. Any future technical modifications of the component are subject to the responsibility of the manufacturer.

Up to a bandwidth of 250 MHz, the specimen, a RJ45-jack, meet the limits of the specified standards and regulations.

This Certificate refers to the comprehensive test report, no. **863/01**, from **20 November 2001** and shall only be applicable in conjunction with the test report.

Bexbach, 20 November 2001



 Dipl.-Ing. Frank Streibert
 (general manager)



GHMT mbH
 In der Kolling 13
 D-66450 Bexbach
 Phone: +49 (0) 69 29 / 92 28 - 0
 Fax: +49 (0) 69 29 / 92 29 - 99
 E-Mail: info@ghmt.de
 http://www.ghmt.de

Gesellschaft für Hochfrequenz - Meßtechnik mbH

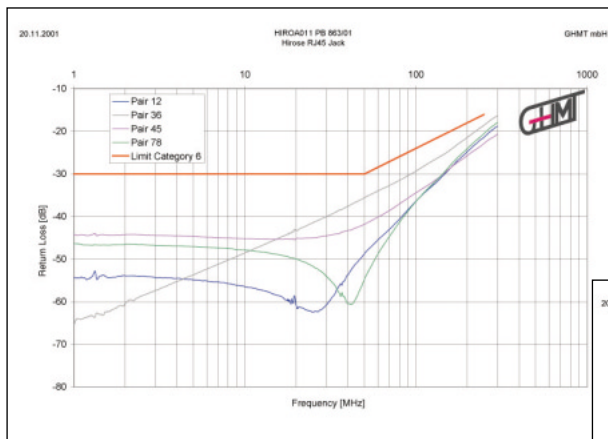
Certificate of Acceptance



↑ Return Loss

NEXT →

