

FEATURES

- Eight Low-Side Drivers With Internal Clamp for Inductive Loads and Current Limiting for Self Protection
 - Seven Outputs Rated at 150 mA and Controlled Through Serial Interface
 - One Output Rated at 150 mA and Controlled Through Serial Interface and Dedicated Enable Pin
- 5-V \pm 5% Regulated Power Supply With 200-mA Load Capability at V_{IN} Max of 18 V
- Internal Voltage Supervisory for Regulated Output
- Serial Communications for Control of Eight Low-Side Drivers
- Enable/Disable Input for OUT1
- 5-V or 3.3-V I/O Tolerant for Interface to Microcontroller
- Programmable Power-On Reset Delay Before \overline{RST} Asserted High, Once 5 V Is Within Specified Range (6 ms Typ)
- Programmable Deglitch Timer Before \overline{RST} Asserted Low (40 μ s Typ)
- Programmable Brown-Out Feature
- Thermal Shutoff for Self Protection

APPLICATIONS

- Electrical Appliances
 - Air Conditioning Units
 - Ranges
 - Dishwashers
 - Refrigerators
 - Microwaves
 - Washing Machines
- General-Purpose Interface Circuit Allowing Microcontroller Interface to Relays, Electric Motors, LEDs, and Buzzers

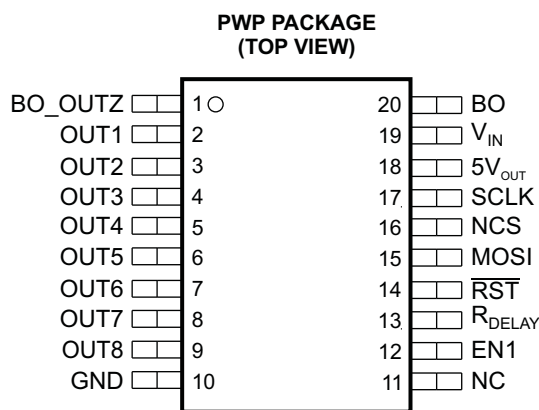

NC – No internal connection

DESCRIPTION/ORDERING INFORMATION

The power supply provides regulated 5-V output to power the system microcontroller and drive eight low-side switches. The brown-out detection output (BO_OUTZ) warns the system if there is a temporary drop in the supply voltage, so the system can prevent potentially hazardous situations.

A serial communications interface controls the eight low-side outputs; each output has an internal snubber circuit to absorb the inductive load at turn OFF. Alternatively, the system can use a fly-back diode to V_{IN} to help recirculate the energy in an inductive load at turn OFF.

ORDERING INFORMATION⁽¹⁾

T_A	PACKAGE ⁽²⁾	ORDERABLE PART NUMBER	TOP-SIDE MARKING
–40°C to 125°C	PowerPAD™ – PWP	Reel of 2000	TPL9202PWPR
		Tube of 70	TPL9202PWP
			PL202

(1) For the most current package and ordering information, see the Package Option Addendum at the end of this document, or see the TI web site at www.ti.com.

(2) Package drawings, thermal data, and symbolization are available at www.ti.com/packaging.



Please be aware that an important notice concerning availability, standard warranty, and use in critical applications of Texas Instruments semiconductor products and disclaimers thereto appears at the end of this data sheet.

PowerPAD is a trademark of Texas Instruments.

TPL9202
8-CHANNEL RELAY DRIVER
WITH INTEGRATED 5-V LDO AND BROWN-OUT DETECTION

SLIS124D–JUNE 2006–REVISED FEBRUARY 2008

PINOUT CONFIGURATION

NO.	NAME	I/O	DESCRIPTION
1	BO_OUTZ	O	Brown-out indicator
2	OUT1	O	Low-side output 1
3	OUT2	O	Low-side output 2
4	OUT3	O	Low-side output 3
5	OUT4	O	Low-side output 4
6	OUT5	O	Low-side output 5
7	OUT6	O	Low-side output 6
8	OUT7	O	Low-side output 7
9	OUT8	O	Low-side output 8
10	GND	I	Ground
11	NC		No connection
12	EN1	I	Enable/disable for OUT1
13	R _{DELAY}	O	Power-up reset delay
14 ⁽¹⁾	$\overline{\text{RST}}$	I/O	Power-on reset output (open drain)
15	MOSI	I	Serial data input
16	NCS	I	Chip select
17	SCLK	I	Serial clock for data synchronization
18	5V _{OUT}	O	Regulated output
19	V _{IN}	I	Unregulated input voltage source
20	BO	I	Brown-out input threshold setting

(1) Terminal 14 can be used as an input or an output.

FUNCTIONAL BLOCK DIAGRAM

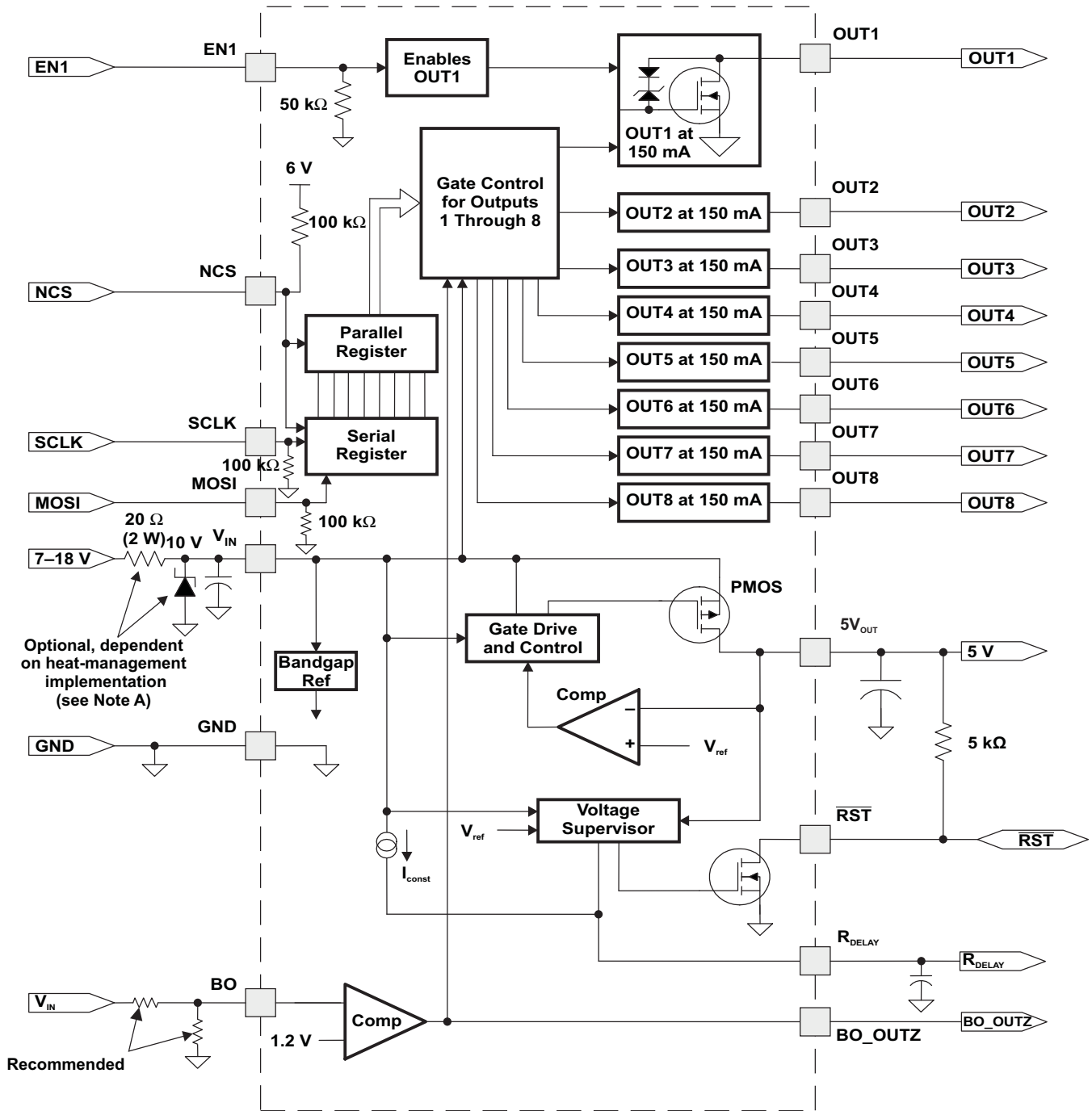

A. The resistor and Zener diode are required if there is insufficient thermal-management allocation.

TPL9202

8-CHANNEL RELAY DRIVER WITH INTEGRATED 5-V LDO AND BROWN-OUT DETECTION

SLIS124D–JUNE 2006–REVISED FEBRUARY 2008

DETAILED DESCRIPTION

The 5-V regulator is powered from V_{IN} , and the regulated output is within $5\text{ V} \pm 5\%$ over the operating conditions. The open-drain power-on reset (\overline{RST}) pin remains low until the regulator exceeds the set threshold, and the timer value set by the capacitor on the reset delay (R_{DELAY}) pin expires. If both of these conditions are satisfied, \overline{RST} is asserted high. This signifies to the microcontroller that serial communications can be initiated to the TPL9202.

The serial communications is an 8-bit format, with data transfer synchronized using a serial clock from the microcontroller. A single register controls all the outputs (one bit per output). The default value is zero (OFF). If an output requires pulse width modulation (PWM) function, the register must be updated at a rate faster than the desired PWM frequency. OUT1 can be controlled by serial input from the microcontroller or with the dedicated enable (EN1) pin. If EN1 is pulled low or left open, the serial input through the shift register controls OUT1. If EN1 is pulled high, OUT1 always is turned on, and the serial input for OUT1 is ignored.

The brown-out (BO) input is a resistor divided from the input supply and is used to determine if the supply voltage drops to undesired levels. If the input drops below the programmed value, BO_OUTZ is pulled low, and all outputs are disabled. Once the input supply line returns to the minimum desired level, the outputs are enabled to the previous programmed states.

If \overline{RST} is asserted, all outputs are turned OFF internally, and the input register is reset to all zeroes. The microcontroller must write to the register to turn the outputs ON again.

Absolute Maximum Ratings⁽¹⁾

		MIN	MAX	UNIT
$V_{I(\text{unreg})}$	Unregulated input voltage ^{(2) (3)}	V_{IN}	24	V
		BO	24	
$V_{I(\text{logic})}$	Logic input voltage ^{(2) (3)}	EN1, MOSI, SCLK, and NCS	7	V
		\overline{RST} and R_{DELAY}	7	
V_O	Low-side output voltage		16.5	V
I_{LIMIT}	Output current limit ⁽⁴⁾	OUTn = ON and shorted to V_{IN} with low impedance		350 mA
θ_{JA}	Thermal impedance, junction to ambient ⁽⁵⁾		33	°C/W
θ_{JC}	Thermal impedance, junction to top of package ⁽⁵⁾		20	°C/W
θ_{JP}	Thermal impedance, junction to thermal pad ⁽⁵⁾		1.4	°C/W
P_D	Continuous power dissipation ⁽⁶⁾		3.7	W
ESD	Electrostatic discharge ⁽⁷⁾		2	kV
T_A	Operating ambient temperature range	–40	125	°C
T_{stg}	Storage temperature range	–65	125	°C
T_{lead}	Lead temperature	Soldering, 10 s		260 °C

- (1) Stresses beyond those listed under "absolute maximum ratings" may cause permanent damage to the device. These are stress ratings only and functional operation of the device at these or any other conditions beyond those indicated under "recommended operating conditions" is not implied. Exposure to absolute-maximum-rated conditions for extended periods may affect device reliability.
- (2) All voltage values are with respect to GND.
- (3) Absolute negative voltage on these pins must not go below –0.5 V.
- (4) Not more than one output should be shorted at a time, and duration of the short circuit should not exceed 1 ms.
- (5) The thermal data is based on using 1-oz copper trace with JEDEC 51-5 test board for PWP.
- (6) The data is based on ambient temperature of 25°C maximum.
- (7) The Human Body Model is a 100-pF capacitor discharged through a 1.5-k Ω resistor into each pin.

Dissipation Ratings

PACKAGE	$T_A \leq 25^\circ\text{C}$ POWER RATING	DERATING FACTOR ABOVE $T_A = 25^\circ\text{C}$	$T_A = 125^\circ\text{C}$ POWER RATING
PWP	3787 mW	30.3 mW/°C	757 mW

Recommended Operating Conditions

		MIN	MAX	UNIT
$V_{I(\text{unreg})}$	Unregulated input voltage	V_{IN}	7	18
		BO (as seen by external resistor network)	0	
$V_{I(\text{logic})}$	Logic input voltage	EN1, \overline{RST} , and R_{DELAY} , MOSI, SCLK, and NCS		5.25 V
T_A	Operating ambient temperature	–40	125	°C

TPL9202

8-CHANNEL RELAY DRIVER

WITH INTEGRATED 5-V LDO AND BROWN-OUT DETECTION

SLIS124D–JUNE 2006–REVISED FEBRUARY 2008

Electrical Characteristics

$T_A = -40^{\circ}\text{C}$ to 125°C , $V_{IN} = 7\text{ V}$ to 18 V (unless otherwise noted)

PARAMETER	TEST CONDITIONS	MIN	TYP ⁽¹⁾	MAX	UNIT		
Supply Voltage and Current							
$V_{IN}^{(2)}$	Input voltage	7		18	V		
I_{IN}	Input supply current	Enable = low, OUT1–OUT8 = Off		3	mA		
		Enable = high, OUT1–OUT8 = On		5			
Logic Inputs (MOSI, NCS, SCLK, and EN1)							
V_{IL}	Logic input low level	$I_{IL} = 100\ \mu\text{A}$		0.8	V		
V_{IH}	Logic input high level	$I_{IL} = 100\ \mu\text{A}$		2.4	V		
Reset (RST)							
V_{OL}	Low-level logic output	$I_{OL} = 1.6\ \text{mA}$		0.4	V		
$V_{OH}^{(3)}$	High-level logic output	5-k Ω pullup to V_{CC}		$V_{CC} - 0.8$	V		
V_H	Disabling reset threshold	5-V regulator ramps up		4.25	4.5	V	
V_L	Enabling reset threshold	5-V regulator ramps down		3.3	3.75	V	
V_{HYS}	Threshold hysteresis			0.12	0.5	V	
Reset Delay (R_{DELAY})							
I_{OUT}	Output current			18	28	48	μA
t_{DW}	Reset delay timer	$C = 47\ \text{nF}$		3	6		ms
t_{UP}	Reset capacitor to low level	$C = 47\ \text{nF}$		45			μs
Output (OUT1–OUT8)							
V_{OL}	Output ON	$I_{OUTn} = 150\ \text{mA}$		0.4	0.7		V
I_{OH}	Output leakage	$V_{OH} = \text{Max of } 16.5\ \text{V}$		2			μA
Regulator Output (5V_{OUT})							
5V _{OUT}	Output supply	$I_{5V_{OUT}} = 5\ \text{mA}$ to $200\ \text{mA}$, $V_{IN} = 7\ \text{V}$ to $18\ \text{V}$, $C_{5V_{OUT}} = 1\ \mu\text{F}$		4.75	5	5.25	V
$I_{5V_{out}}$	Limit output short circuit current	$5V_{OUT} = 0\ \text{V}$		200			mA
Brown-Out (BO) Input							
BOV_{thes}	Threshold for brown-out detection	V_{IN} reduced until BO_OUTZ goes low		1.3			V
Brown-Out Detection Output (BO_OUTZ)							
V_{OL}	Logic level output	$I_{OL} = 100\ \mu\text{A}$		0.4			V
$V_{OH}^{(3)}$	Logic level output	Pullup to V_{CC}		$V_{CC} - 0.8$			V
Thermal Shutdown							
T_{SD}	Thermal shutdown			150			$^{\circ}\text{C}$
T_{HYS}	Hysteresis			20			$^{\circ}\text{C}$

(1) All typical values are at $T_A = 25^{\circ}\text{C}$.

(2) There are external high-frequency noise-suppression capacitors and filter capacitors on V_{IN} .

(3) V_{CC} is the pullup resistor voltage.

Output Control Register

MSB						LSB	
IN8	IN7	IN6	IN5	IN4	IN3	IN2	IN1
0	0	0	0	0	0	0	0

INn = 0 = Output OFF

INn = 1 = Output ON

To operate the output in PWM mode, the output control register must be updated at a rate twice the desired PWM frequency of the output. Maximum PWM frequency is 5 kHz. The register is updated every 100 μ s.

ENABLE TRUTH TABLE

EN1	SERIAL INPUT FOR OUT1	OUT1
Open	H	On
Open	L	Off
L	H	On
L	L	Off
H	H	On
H	L	On

TPL9202

8-CHANNEL RELAY DRIVER

WITH INTEGRATED 5-V LDO AND BROWN-OUT DETECTION

SLIS124D–JUNE 2006–REVISED FEBRUARY 2008

Serial Communications Interface

The serial communications are an 8-bit format, with data transfer synchronized using a serial clock from the microcontroller (see [Figure 1](#)). A single register controls all the outputs. The signal gives the instruction to control the output of TPL9202.

The NCS signal enables the SCLK and MOSI data when it is low. After NCS is set to low for T1, synchronization clock and data begin to transmit and, after the 8-bit data has been transmitted, NCS is set high again to disable SCLK and MOSI and to transfer the serial data to the control register. SCLK must be held low when NCS is high.

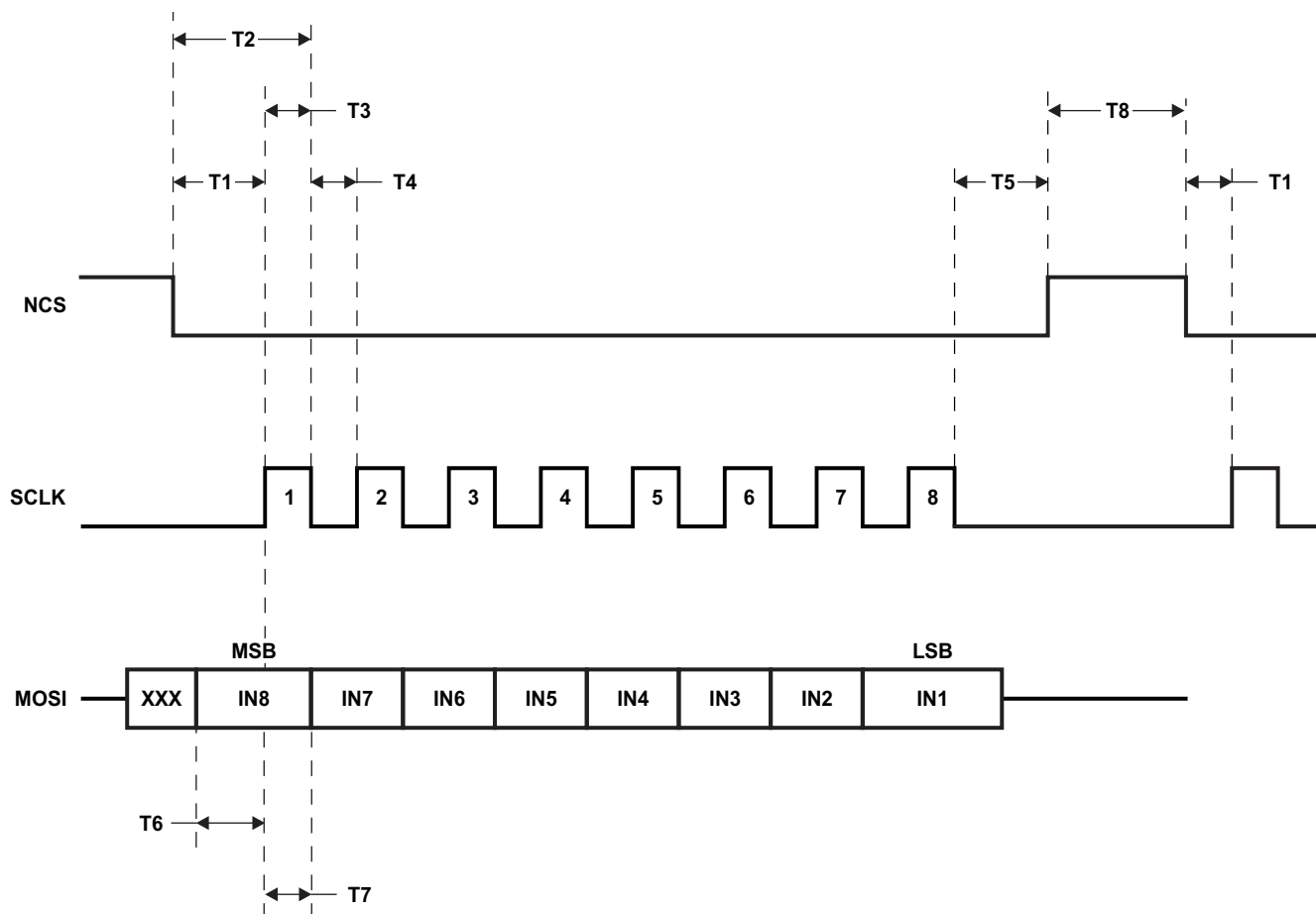

Figure 1. Serial Communications

Timing Requirements

$T_A = -40^\circ\text{C}$ to 125°C , $V_{IN} = 7\text{ V}$ to 18 V (unless otherwise noted)

		MIN	TYP	MAX	UNIT
f_{SPI}	SPI frequency		4		MHz
T1	Delay time, NCS falling edge to SCLK rising edge	10			ns
T2	Delay time, NCS falling edge to SCLK falling edge	80			ns
T3	Pulse duration, SCLK high	60			ns
T4	Pulse duration, SCLK low	60			ns
T5	Delay time, last SCLK falling edge to NCS rising edge	80			ns
T6	Setup time, MOSI valid before SCLK edge	10			ns
T7	Hold time, MOSI valid after SCLK edge	10			ns
T8	Time between two words for transmitting	170			ns

Reset Delay (R_{DELAY})

The R_{DELAY} output provides a constant current source to charge an external capacitor to approximately 6.5 V. The external capacitor is selected to provide a delay time, based on the current equation for a capacitor, $I = C(\Delta v/\Delta t)$ and a 28- μA typical output current.

Therefore, the user should select a 47-nF capacitor to provide a 6-ms delay at 3.55 V.

$$I = C(\Delta v/\Delta t)$$

$$28\ \mu\text{A} = C \times (3.55\ \text{V}/6\ \text{ms})$$

$$C = 47\ \text{nF}$$

TPL9202
8-CHANNEL RELAY DRIVER
WITH INTEGRATED 5-V LDO AND BROWN-OUT DETECTION

SLIS124D—JUNE 2006—REVISED FEBRUARY 2008

APPLICATION INFORMATION

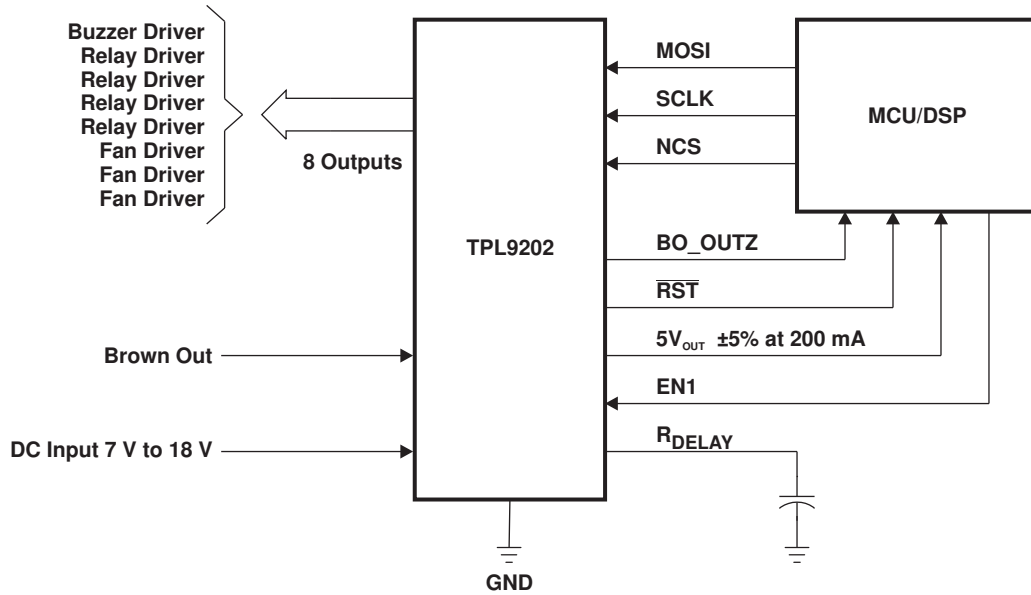

Figure 2. Typical Application

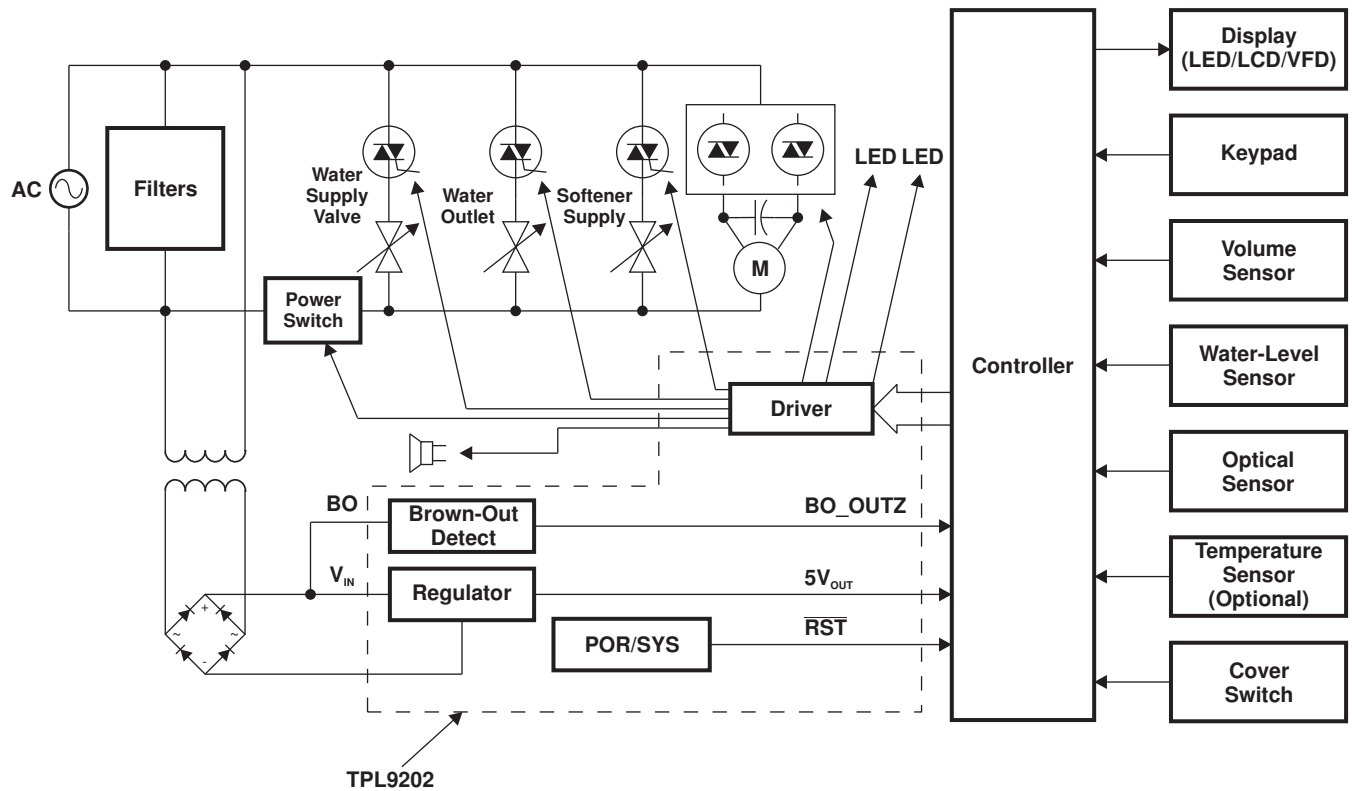

Figure 3. Washing-Machine Application

PCB Layout

To maximize the efficiency of this package for application on a single layer or multilayer PCB, certain guidelines must be followed when laying out this part on the PCB.

The following information is to be used as a guideline only.

For further information, see the PowerPAD concept implementation document.

Application Using a Multilayer PCB

In a multilayer board application, the thermal vias are the primary method of heat transfer from the package thermal pad to the internal ground plane (see [Figure 4](#) and [Figure 5](#)).

The efficiency of this method depends on several factors: die area, number of thermal vias, thickness of copper, etc. (see the *PowerPAD™ Thermally Enhanced Package Technical Brief*, literature number [SLMA002](#)).

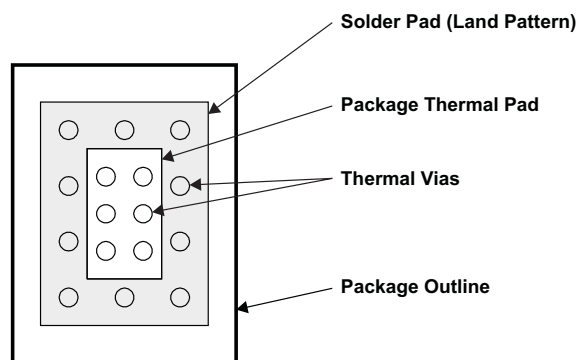

Figure 4. Package and PCB Land Configuration for a Multilayer PCB

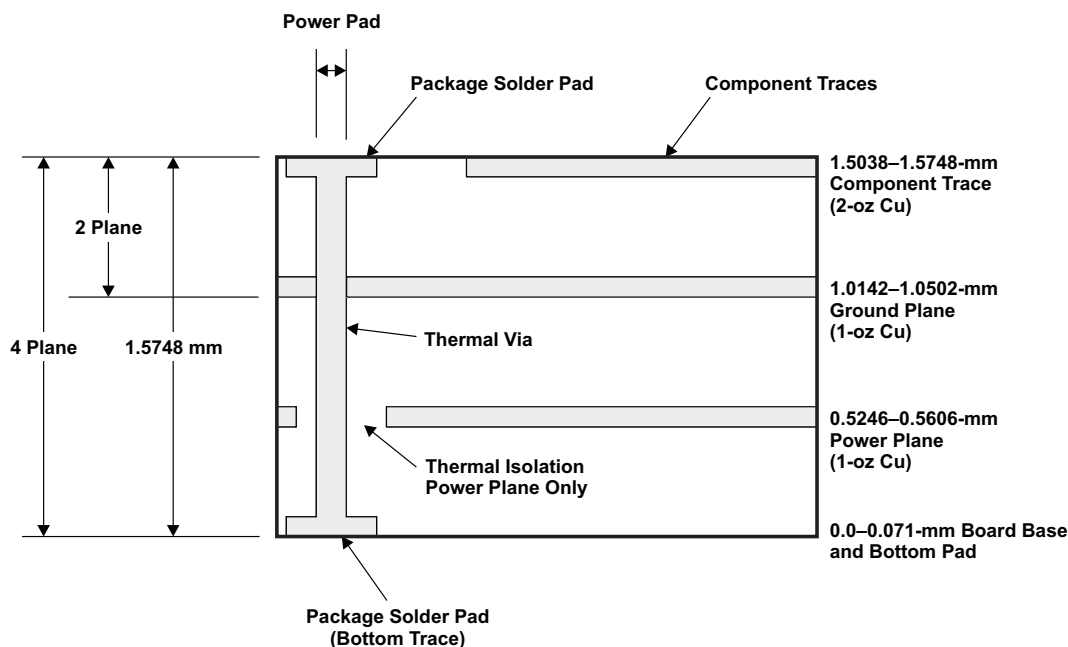

Figure 5. Multilayer Board (Side View)

Application Using a Single-Layer PCB

In a single-layer board application, the thermal pad is attached to a heat spreader (copper areas) by a low thermal-impedance attachment method (solder paste or thermal conductive epoxy). With either method, it is advisable to use as many copper traces as possible to dissipate the heat.

TPL9202

8-CHANNEL RELAY DRIVER

WITH INTEGRATED 5-V LDO AND BROWN-OUT DETECTION

SLIS124D–JUNE 2006–REVISED FEBRUARY 2008

CAUTION:

If the attachment method is not implemented correctly, the functionality of the product cannot be ensured. Power-dissipation capability is adversely affected if the device is incorrectly mounted on the circuit board.

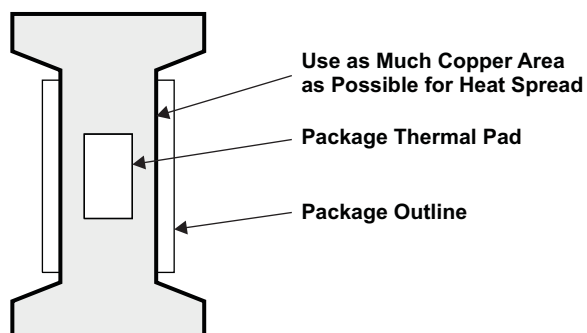

Figure 6. Layout Recommendations for a Single-Layer PCB

Recommended Board Layout

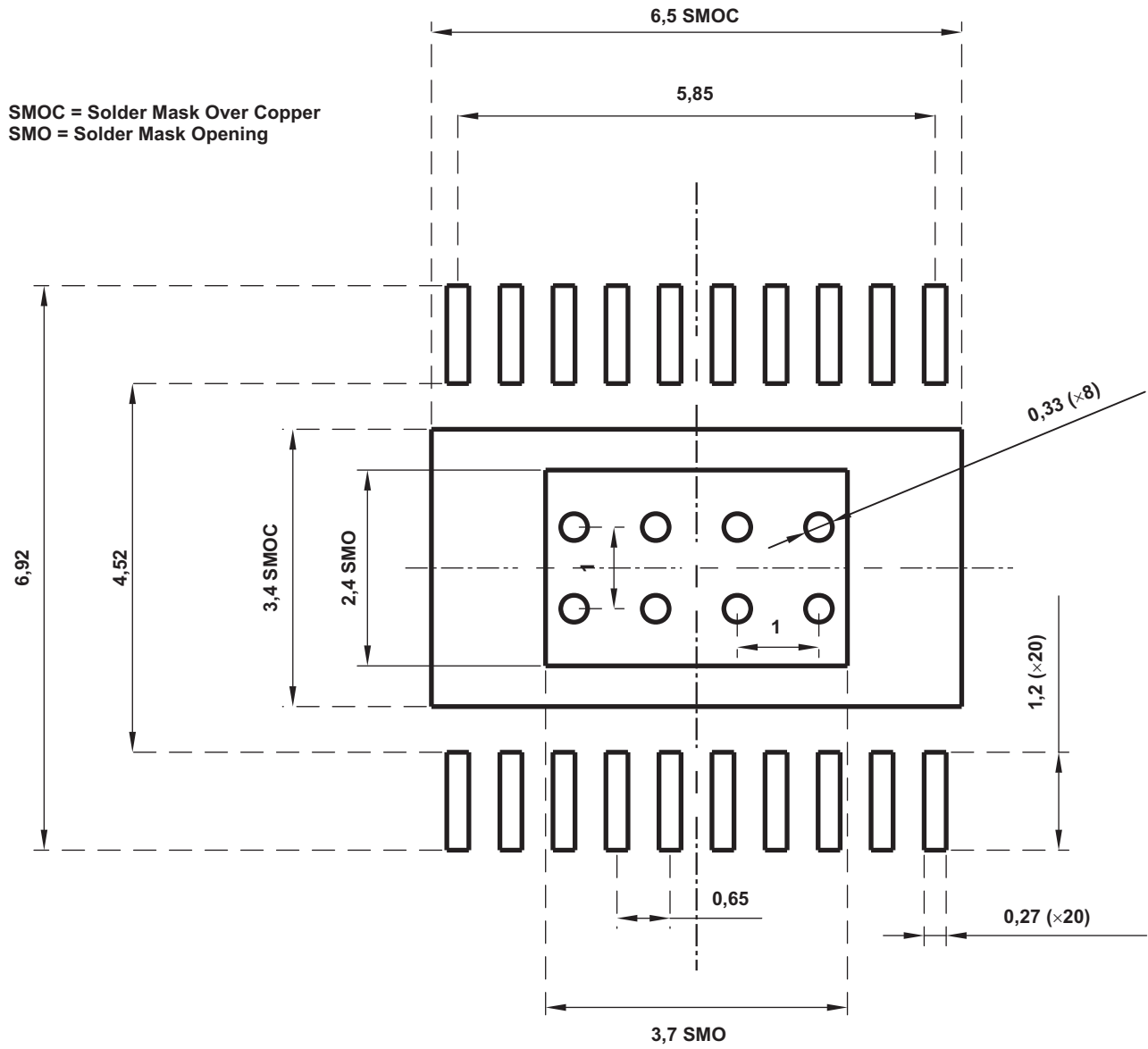

Figure 7. Recommended Board Layout for PWP

PACKAGING INFORMATION

Orderable Device	Status ⁽¹⁾	Package Type	Package Drawing	Pins	Package Qty	Eco Plan ⁽²⁾	Lead/Ball Finish	MSL Peak Temp ⁽³⁾
TPL9202PWP	ACTIVE	HTSSOP	PWP	20	70	Green (RoHS & no Sb/Br)	CU NIPDAU	Level-2-260C-1 YEAR
TPL9202PWPG4	ACTIVE	HTSSOP	PWP	20	70	Green (RoHS & no Sb/Br)	CU NIPDAU	Level-2-260C-1 YEAR
TPL9202PWPR	ACTIVE	HTSSOP	PWP	20	2000	Green (RoHS & no Sb/Br)	CU NIPDAU	Level-2-260C-1 YEAR
TPL9202PWPRG4	ACTIVE	HTSSOP	PWP	20	2000	Green (RoHS & no Sb/Br)	CU NIPDAU	Level-2-260C-1 YEAR

⁽¹⁾ The marketing status values are defined as follows:

ACTIVE: Product device recommended for new designs.

LIFEBUY: TI has announced that the device will be discontinued, and a lifetime-buy period is in effect.

NRND: Not recommended for new designs. Device is in production to support existing customers, but TI does not recommend using this part in a new design.

PREVIEW: Device has been announced but is not in production. Samples may or may not be available.

OBSOLETE: TI has discontinued the production of the device.

⁽²⁾ Eco Plan - The planned eco-friendly classification: Pb-Free (RoHS), Pb-Free (RoHS Exempt), or Green (RoHS & no Sb/Br) - please check <http://www.ti.com/productcontent> for the latest availability information and additional product content details.

TBD: The Pb-Free/Green conversion plan has not been defined.

Pb-Free (RoHS): TI's terms "Lead-Free" or "Pb-Free" mean semiconductor products that are compatible with the current RoHS requirements for all 6 substances, including the requirement that lead not exceed 0.1% by weight in homogeneous materials. Where designed to be soldered at high temperatures, TI Pb-Free products are suitable for use in specified lead-free processes.

Pb-Free (RoHS Exempt): This component has a RoHS exemption for either 1) lead-based flip-chip solder bumps used between the die and package, or 2) lead-based die adhesive used between the die and leadframe. The component is otherwise considered Pb-Free (RoHS compatible) as defined above.

Green (RoHS & no Sb/Br): TI defines "Green" to mean Pb-Free (RoHS compatible), and free of Bromine (Br) and Antimony (Sb) based flame retardants (Br or Sb do not exceed 0.1% by weight in homogeneous material)

⁽³⁾ MSL, Peak Temp. -- The Moisture Sensitivity Level rating according to the JEDEC industry standard classifications, and peak solder temperature.

Important Information and Disclaimer:The information provided on this page represents TI's knowledge and belief as of the date that it is provided. TI bases its knowledge and belief on information provided by third parties, and makes no representation or warranty as to the accuracy of such information. Efforts are underway to better integrate information from third parties. TI has taken and continues to take reasonable steps to provide representative and accurate information but may not have conducted destructive testing or chemical analysis on incoming materials and chemicals. TI and TI suppliers consider certain information to be proprietary, and thus CAS numbers and other limited information may not be available for release.

In no event shall TI's liability arising out of such information exceed the total purchase price of the TI part(s) at issue in this document sold by TI to Customer on an annual basis.

TAPE AND REEL INFORMATION



QUADRANT ASSIGNMENTS FOR PIN 1 ORIENTATION IN TAPE



*All dimensions are nominal

Device	Package Type	Package Drawing	Pins	SPQ	Reel Diameter (mm)	Reel Width W1 (mm)	A0 (mm)	B0 (mm)	K0 (mm)	P1 (mm)	W (mm)	Pin1 Quadrant
TPL9202PWPR	HTSSOP	PWP	20	2000	330.0	16.4	6.95	7.1	1.6	8.0	16.0	Q1

TAPE AND REEL BOX DIMENSIONS



*All dimensions are nominal

Device	Package Type	Package Drawing	Pins	SPQ	Length (mm)	Width (mm)	Height (mm)
TPL9202PWPR	HTSSOP	PWP	20	2000	346.0	346.0	33.0

MECHANICAL DATA

PWP (R-PDSO-G**) 20 PIN SHOWN

PowerPAD™ PLASTIC SMALL-OUTLINE PACKAGE

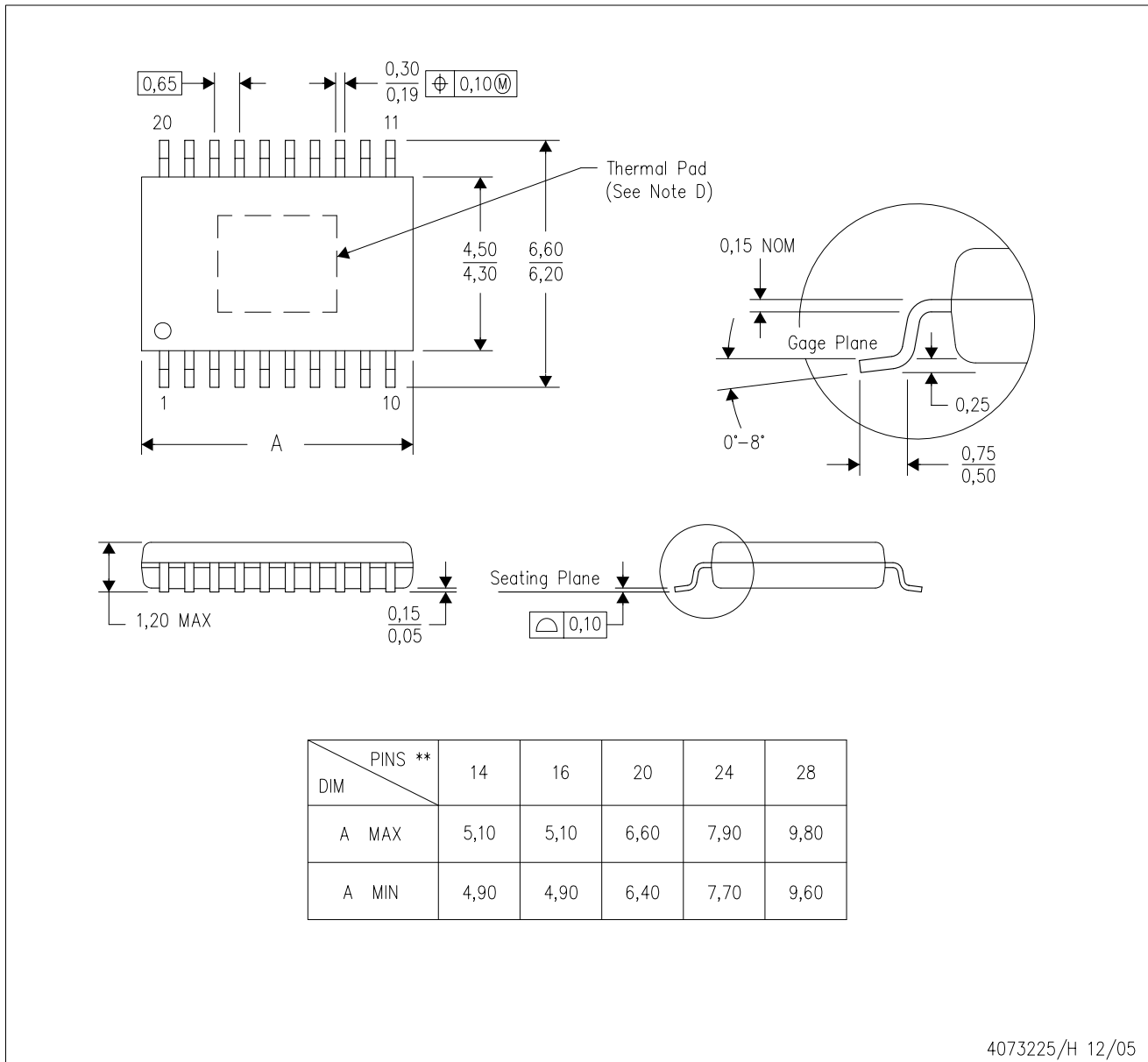

4073225/H 12/05

- NOTES:
- All linear dimensions are in millimeters.
 - This drawing is subject to change without notice.
 - Body dimensions do not include mold flash or protrusions. Mold flash and protrusion shall not exceed 0.15 per side.
 - This package is designed to be soldered to a thermal pad on the board. Refer to Technical Brief, PowerPad Thermally Enhanced Package, Texas Instruments Literature No. SLMA002 for information regarding recommended board layout. This document is available at www.ti.com <<http://www.ti.com>>.
 - Falls within JEDEC MO-153

PowerPAD is a trademark of Texas Instruments.

THERMAL PAD MECHANICAL DATA

PWP (R-PDSO-G20)

PowerPAD™ SMALL PLASTIC OUTLINE

THERMAL INFORMATION

This PowerPAD™ package incorporates an exposed thermal pad that is designed to be attached to a printed circuit board (PCB). The thermal pad must be soldered directly to the PCB. After soldering, the PCB can be used as a heatsink. In addition, through the use of thermal vias, the thermal pad can be attached directly to the appropriate copper plane shown in the electrical schematic for the device, or alternatively, can be attached to a special heatsink structure designed into the PCB. This design optimizes the heat transfer from the integrated circuit (IC).

For additional information on the PowerPAD package and how to take advantage of its heat dissipating abilities, refer to Technical Brief, PowerPAD Thermally Enhanced Package, Texas Instruments Literature No. SLMA002 and Application Brief, PowerPAD Made Easy, Texas Instruments Literature No. SLMA004. Both documents are available at www.ti.com.

The exposed thermal pad dimensions for this package are shown in the following illustration.

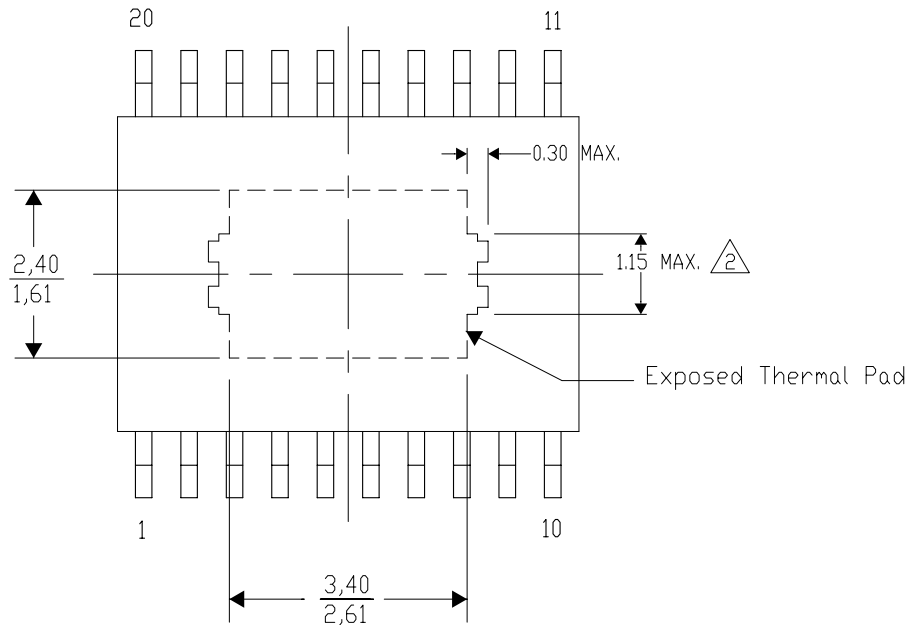

Top View

NOTES:

1. All linear dimensions are in millimeters
- $\triangle 2$ Exposed tie strap features may not be present.

Exposed Thermal Pad Dimensions

PWP (R-PDSO-G20)

PowerPAD™ PLASTIC SMALL OUTLINE

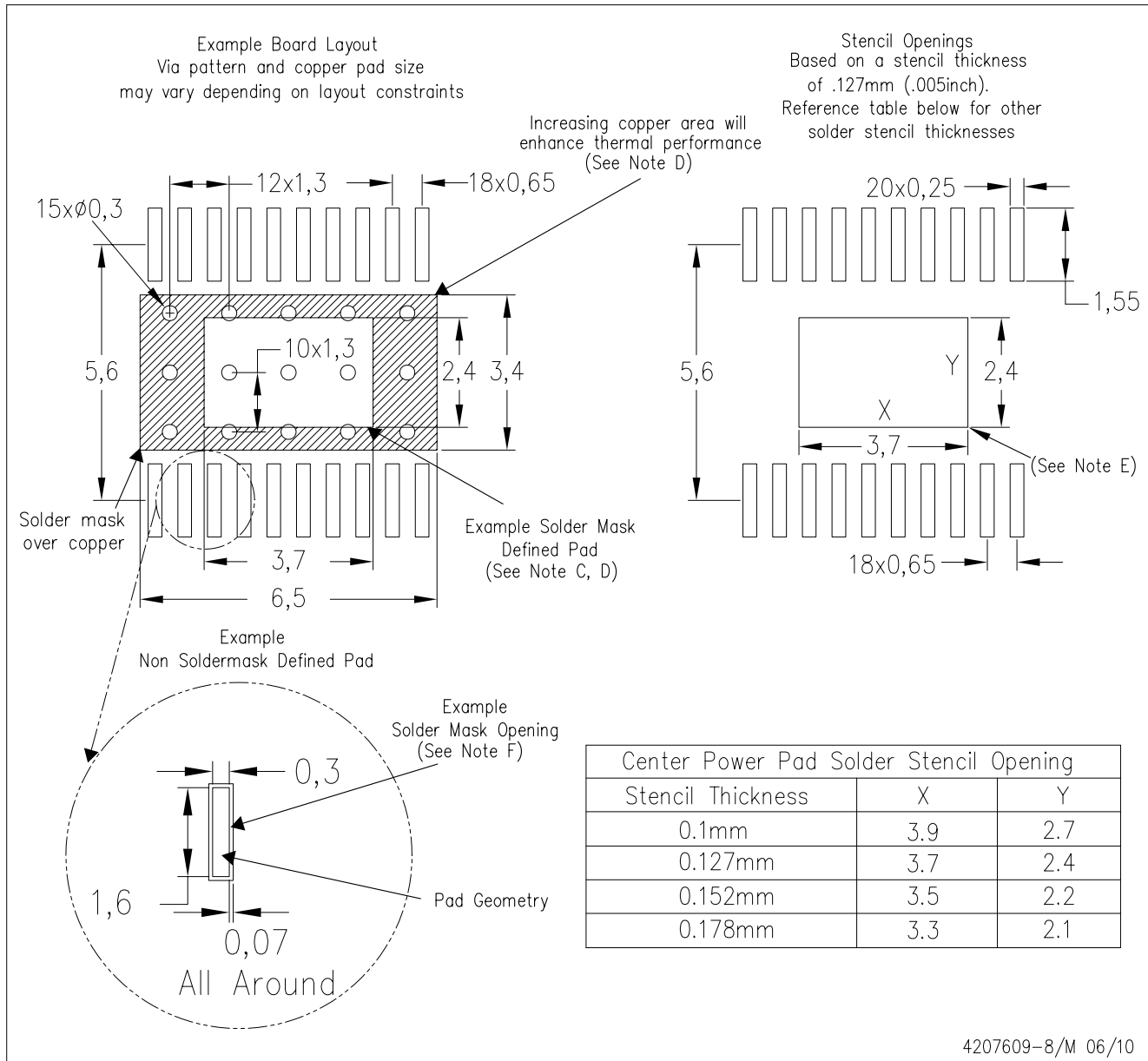

- NOTES:
- A. All linear dimensions are in millimeters.
 - B. This drawing is subject to change without notice.
 - C. Customers should place a note on the circuit board fabrication drawing not to alter the center solder mask defined pad.
 - D. This package is designed to be soldered to a thermal pad on the board. Refer to Technical Brief, PowerPad Thermally Enhanced Package, Texas Instruments Literature No. SLMA002, SLMA004, and also the Product Data Sheets for specific thermal information, via requirements, and recommended board layout. These documents are available at www.ti.com <<http://www.ti.com>>. Publication IPC-7351 is recommended for alternate designs.
 - E. Laser cutting apertures with trapezoidal walls and also rounding corners will offer better paste release. Customers should contact their board assembly site for stencil design recommendations. Example stencil design based on a 50% volumetric metal load solder paste. Refer to IPC-7525 for other stencil recommendations.
 - F. Customers should contact their board fabrication site for solder mask tolerances between and around signal pads.

PowerPAD is a trademark of Texas Instruments.

IMPORTANT NOTICE

Texas Instruments Incorporated and its subsidiaries (TI) reserve the right to make corrections, modifications, enhancements, improvements, and other changes to its products and services at any time and to discontinue any product or service without notice. Customers should obtain the latest relevant information before placing orders and should verify that such information is current and complete. All products are sold subject to TI's terms and conditions of sale supplied at the time of order acknowledgment.

TI warrants performance of its hardware products to the specifications applicable at the time of sale in accordance with TI's standard warranty. Testing and other quality control techniques are used to the extent TI deems necessary to support this warranty. Except where mandated by government requirements, testing of all parameters of each product is not necessarily performed.

TI assumes no liability for applications assistance or customer product design. Customers are responsible for their products and applications using TI components. To minimize the risks associated with customer products and applications, customers should provide adequate design and operating safeguards.

TI does not warrant or represent that any license, either express or implied, is granted under any TI patent right, copyright, mask work right, or other TI intellectual property right relating to any combination, machine, or process in which TI products or services are used. Information published by TI regarding third-party products or services does not constitute a license from TI to use such products or services or a warranty or endorsement thereof. Use of such information may require a license from a third party under the patents or other intellectual property of the third party, or a license from TI under the patents or other intellectual property of TI.

Reproduction of TI information in TI data books or data sheets is permissible only if reproduction is without alteration and is accompanied by all associated warranties, conditions, limitations, and notices. Reproduction of this information with alteration is an unfair and deceptive business practice. TI is not responsible or liable for such altered documentation. Information of third parties may be subject to additional restrictions.

Resale of TI products or services with statements different from or beyond the parameters stated by TI for that product or service voids all express and any implied warranties for the associated TI product or service and is an unfair and deceptive business practice. TI is not responsible or liable for any such statements.

TI products are not authorized for use in safety-critical applications (such as life support) where a failure of the TI product would reasonably be expected to cause severe personal injury or death, unless officers of the parties have executed an agreement specifically governing such use. Buyers represent that they have all necessary expertise in the safety and regulatory ramifications of their applications, and acknowledge and agree that they are solely responsible for all legal, regulatory and safety-related requirements concerning their products and any use of TI products in such safety-critical applications, notwithstanding any applications-related information or support that may be provided by TI. Further, Buyers must fully indemnify TI and its representatives against any damages arising out of the use of TI products in such safety-critical applications.

TI products are neither designed nor intended for use in military/aerospace applications or environments unless the TI products are specifically designated by TI as military-grade or "enhanced plastic." Only products designated by TI as military-grade meet military specifications. Buyers acknowledge and agree that any such use of TI products which TI has not designated as military-grade is solely at the Buyer's risk, and that they are solely responsible for compliance with all legal and regulatory requirements in connection with such use.

TI products are neither designed nor intended for use in automotive applications or environments unless the specific TI products are designated by TI as compliant with ISO/TS 16949 requirements. Buyers acknowledge and agree that, if they use any non-designated products in automotive applications, TI will not be responsible for any failure to meet such requirements.

Following are URLs where you can obtain information on other Texas Instruments products and application solutions:

Products		Applications	
Amplifiers	amplifier.ti.com	Audio	www.ti.com/audio
Data Converters	dataconverter.ti.com	Automotive	www.ti.com/automotive
DLP® Products	www.dlp.com	Communications and Telecom	www.ti.com/communications
DSP	dsp.ti.com	Computers and Peripherals	www.ti.com/computers
Clocks and Timers	www.ti.com/clocks	Consumer Electronics	www.ti.com/consumer-apps
Interface	interface.ti.com	Energy	www.ti.com/energy
Logic	logic.ti.com	Industrial	www.ti.com/industrial
Power Mgmt	power.ti.com	Medical	www.ti.com/medical
Microcontrollers	microcontroller.ti.com	Security	www.ti.com/security
RFID	www.ti-rfid.com	Space, Avionics & Defense	www.ti.com/space-avionics-defense
RF/IF and ZigBee® Solutions	www.ti.com/lprf	Video and Imaging	www.ti.com/video
		Wireless	www.ti.com/wireless-apps