

SUPPLY VOLTAGE MONITOR

ZM33064

ISSUE 4 - JANUARY 2003

DEVICE DESCRIPTION

The ZM33064 is a three terminal under voltage monitor circuit for use in microprocessor systems. The threshold voltage of the device has been set to 4.6 volts making it ideal for 5 volt circuits.

Included in the device is a precise voltage reference and a comparator with built in hysteresis to prevent erratic operation. The ZM33064 features an open collector output capable of sinking at least 10mA which only requires a single external resistor to interface to following circuits.

Operation of the device is guaranteed from one volt upwards, from this level to the device threshold voltage the output is held low providing a power on reset function. Should the supply voltage, once established, at any time drop below the threshold level then the output again will pull low.

The device is available in a TO92 package for through hole applications as well as SOT223 for surface mount requirements.

FEATURES

- SOT223 and TO92 packages
- Power on reset generator
- Automatic reset generation
- Low standby current
- Guaranteed operation from 1 volt
- Wide supply voltage range
- Internal clamp diode to discharge delay capacitor
- 4.6 volt threshold for 5 volt logic
- 20mV hysteresis prevents erratic operation

APPLICATIONS

- Microprocessor systems
- Computers
- Computer peripherals
- Instrumentation
- Automotive
- Battery powered equipment

SCHEMATIC DIAGRAM

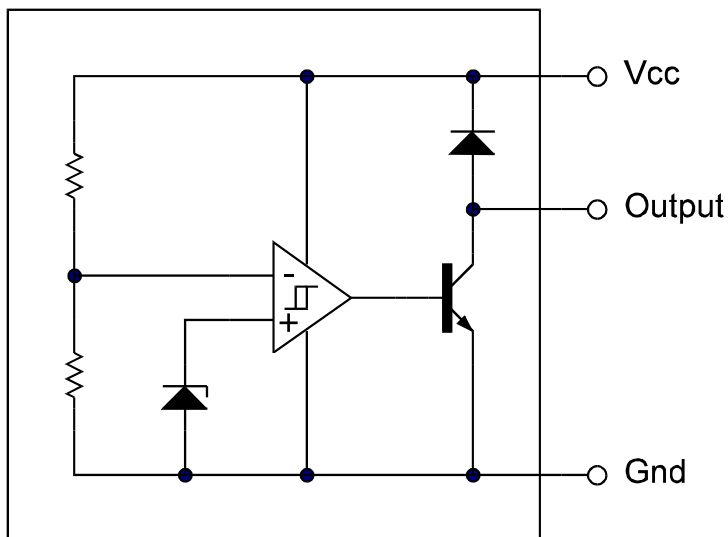

ZM33064

ABSOLUTE MAXIMUM RATING

Input Supply Voltage	-1 to 10V	Power Dissipation	
Offstate Output Voltage	10V	TO92	780mW
Onstate Output		SOT223	2W(Note 2)
Sink Current(Note 1)	Internally limited		
Clamp diode			
Forward Current(Note 1)	100mA		
Operating junction temperature	150°C		
Operating Temperature	-40 to 85°C		
Storage Temperature	-65 to 150°C		

TEST CONDITIONS

($T_{amb}=25^{\circ}\text{C}$ for typical values, $T_{amb}=-40$ to 85°C for min/max values (Note3))

COMPARATOR

PARAMETER	SYMBOL	MIN	TYP.	MAX.	UNITS
Threshold Voltage					
High state output (V _{cc} increasing)	V _{IH}	4.5	4.61	4.7	V
Low state output (V _{cc} decreasing)	V _{IL}	4.5	4.59	4.7	V
Hysteresis	V _H	0.01	0.02	0.05	V

OUTPUT

PARAMETER	SYMBOL	MIN	TYP.	MAX.	UNITS
Output sink saturation: (V _{cc} =4.0V, I _{sink} =8.0mA)	V _{OL}		0.46	1.0	V
(V _{cc} =4.0V, I _{sink} =2.0mA)			0.15	0.4	V
(V _{cc} =1.0V, I _{sink} =0.1mA)				0.25	V
Onstate output sink current (V _{cc} , Output=4V)	I _{sink}	10	20	60	mA
Offstate output leakage current (V _{cc} , Output=5V)	I _{oh}		0.02	0.5	μA
Clamp diode forward voltage (I _f =10mA)	V _f	0.6	1.2	1.5	V
Propagation delay (V _{in} 5V to 4V, R _I =10k, T _{amb} =25°C)	T _d		1.5		μs

TOTAL DEVICE

PARAMETER	SYMBOL	MIN	TYP.	MAX.	UNITS
Operating input voltage range	V _{cc}	1.0 to 6.5			V
Quiescent input current (V _{cc} =5V)	I _q		135	200	μA

Note:

1. Maximum package power dissipation must be observed
2. Maximum power dissipation for the SOT223 package is calculated assuming that the device is mounted on a PCB measuring 2 inches square.
3. Low duty cycle pulse techniques are used during test to maintain junction temperatures as

ZM33064

TYPICAL CHARACTERISTICS

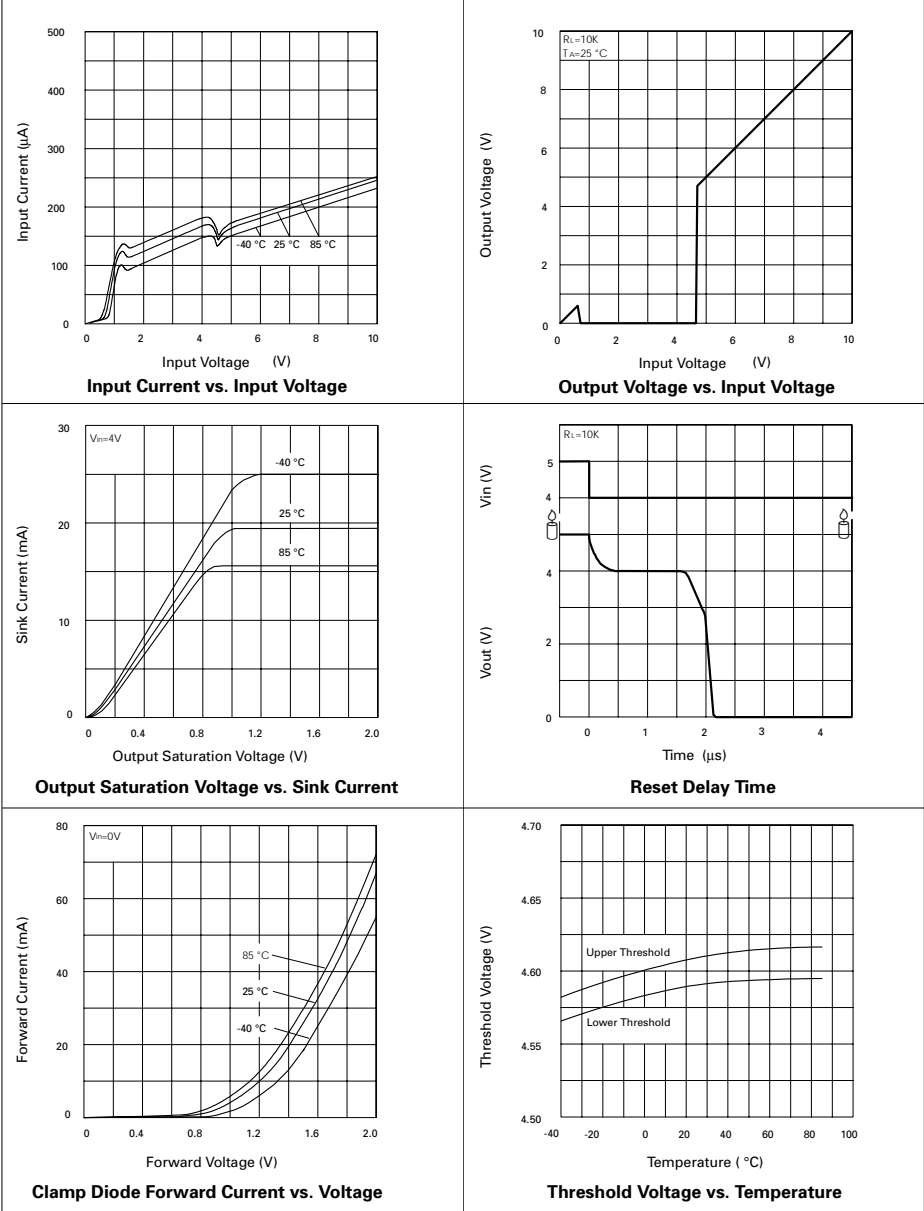

ZM33064

TIMING DIAGRAM

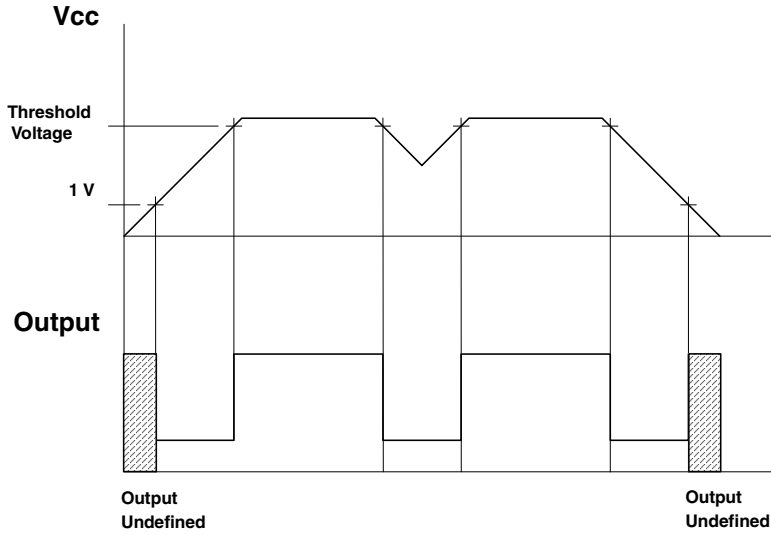

APPLICATION CIRCUIT

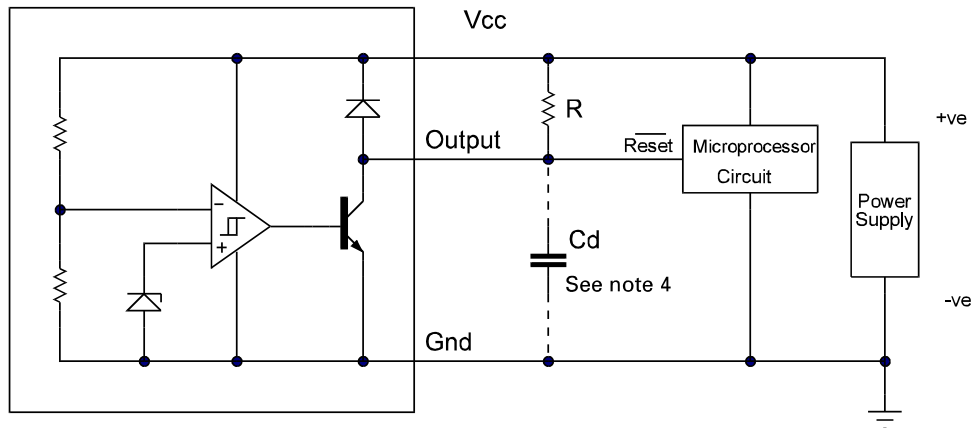

Note 4: A time delayed reset can be accomplished with the additional Cd.

$$T_{DY} = RCd \ln \left(\frac{1}{1 - \frac{V_{TH(mpu)}}{V_{in}}} \right)$$

T_{DY} = Time (Seconds)
 V_{TH} = Microprocessor Reset Threshold
 V_{in} = Power Supply Voltage

ZM33064

CONNECTION DIAGRAMS

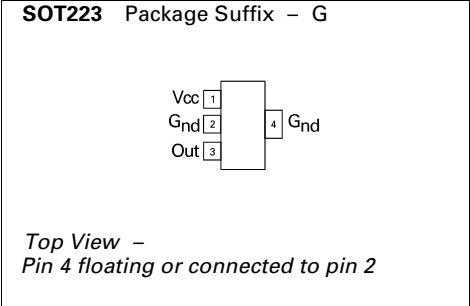
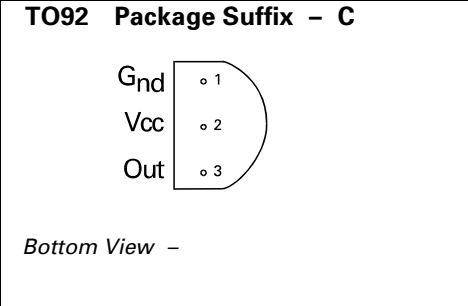

ORDERING INFORMATION

Part Number	Package	Part Mark
ZM33064G	SOT223	ZM33064
ZM33064C	TO92	ZM33064