



ELECTRONICS, INC.

44 FARRAND STREET
BLOOMFIELD, NJ 07003
(973) 748-5089
<http://www.nteinc.com>

NTE6821 Integrated Circuit Peripheral Interface Adapter (PIA), NMOS, 1MHz

Description:

The NTE6821 is a peripheral interface adapter (PIA) in a 40-Lead DIP type package capable of interfacing the Microprocessing Unit (MPU) to peripherals through two 8-Bit bidirectional peripheral data buses and four control lines. No external logic is required for interfacing to most peripheral devices. The functional configuration of the PIA is programmed by the MPU during system initialization. Each of the peripheral data lines can be programmed to act as an input or output, and each of the four control/interrupt lines may be programmed for one of several control modes. This allows a high degree of flexibility in the over-all operation of the interface.

Features:

- 8-Bit Bidirectional Data Bus for Communication with the MPU
- Two Bidirectional 8-Bit Buses for Interface to Peripherals
- Two Programmed Control Registers
- Two Programmed Data Direction Registers
- Four Individually-Controlled Interrupt Input Lines; Two Usable as Peripheral Control Outputs
- Handshake Control Logic for Input and Output Peripheral Operation
- High-Impedance 3-State and Direct Transistor Drive Peripheral Lines
- Program Controlled Interrupt and Interrupt Disable Capability
- CMOS Drive Capability on Side A Peripheral Lines
- Two TTL Drive Capability on All A and B Side Buffers
- TTL Compatible
- Static Operation

Absolute Maximum Ratings: (Note 1)

Supply Voltage, V_{CC}	-0.3 to +7V
Input Voltage, V_{in}	-0.3 to +7V
Operating Temperature Range, T_A	0° to +70°C
Storage Temperature Range, T_{stg}	-55° to +150°C
Thermal Resistance, Junction to Ambient, $R_{\theta JA}$	82.5°C/W

Note 1. This device contains circuitry to protect the inputs against damage due to high static voltages or electric fields; however, it is advised that normal precautions be taken to avoid application of any voltage higher than maximum rated voltages to this high impedance.

Electrical Characteristics: ($V_{CC} = 5V \pm 5\%$, $V_{SS} = 0$, $T_A = 0^\circ$ to $+70^\circ C$ unless otherwise specified)

Parameter	Symbol	Test Conditions	Min	Typ	Max	Unit
Bus Control Inputs ($\overline{R}/\overline{W}$, Enable, Reset, RS0, RS1, CS0, CS1, $\overline{CS2}$)						
Input High Voltage	V_{IH}		$V_{SS} + 2.0$	–	V_{CC}	V
Input Low Voltage	V_{IL}		$V_{SS} - 0.3$	–	$V_{SS} + 0.8$	V
Input Leakage Current	I_{in}	$V_{in} = 0$ to 5.25V	–	1.0	2.5	μA
Capacitance	C_{in}	$V_{in} = 0$, $T_A = +25^\circ C$, $f = 1MHz$	–	–	7.5	pF
Interrupt Outputs (IRQA, IRQB)						
Output Low Voltage	V_{OL}	$I_{Load} = 3.2mA$	–	–	$V_{SS} + 0.4$	V
Output Leakage Current (Off State)	I_{LOH}	$V_{OH} = 2.4V$	–	1.0	10	μA
Capacitance	C_{out}	$V_{in} = 0$, $T_A = +25^\circ C$, $f = 1MHz$	–	–	5.0	pF
Data Bus (D0 – D7)						
Input High Voltage	V_{IH}		$V_{SS} + 2.0$	–	V_{CC}	V
Input Low Voltage	V_{IL}		$V_{SS} - 0.3$	–	$V_{SS} + 0.8$	V
Three–State (Off State) Input Current	I_{TSI}	$V_{in} = 0.4$ to 2.4V	–	2.0	10	μA
Output High Voltage	V_{OH}	$I_{Load} = -205\mu A$	$V_{SS} + 2.4$	–	–	V
Output Low Voltage	V_{OL}	$I_{Load} = 1.6mA$	–	–	$V_{SS} + 0.4$	V
Capacitance	C_{in}	$V_{in} = 0$, $T_A = +25^\circ C$, $f = 1MHz$	–	–	12.5	pF
Peripheral Bus (PA0 – PA7, PB0 – PB7, CA1, CA2, CB1, CB2)						
Input Leakage Current R/W, Reset, RS0, RS1, CS0, CS1, $\overline{CS2}$, CA1, CB1, Enable	I_{in}	$V_{in} = 0$ to 5.25V	–	1.0	2.5	μA
Three–State (Off State) Input Current PB0 – PB7, CB2	I_{TSI}	$V_{in} = 0.4$ to 2.4V	–	2.0	10	μA
Input High Current PA0 – PA7, CA2	I_{IH}	$V_{IH} = 2.4V$	–200	–400	–	μA
Darlington Drive Current PB0 – PB7, CB2	I_{OH}	$V_O = 1.5V$	–1.0	–	–10	mA
Input Low Current PA0 – PA7, CA2	I_{IL}	$V_{IL} = 0.4V$	–	–1.3	–2.4	mA
Output High Voltage PA0 – PA7, PB0 – PB7, CA2, CB2	V_{OH}	$I_{Load} = -200\mu A$	$V_{SS} + 2.4$	–	–	V
PA0 – PA7, CA2		$I_{Load} = 10\mu A$	$V_{CC} - 1.0$	–	–	V
Output Low Voltage	V_{OL}	$I_{Load} = 3.2mA$	–	–	$V_{SS} + 0.4$	V
Capacitance	C_{in}	$V_{in} = 0$, $T_A = +25^\circ C$, $f = 1MHz$	–	–	10	pF
Power Requirements						
Power Dissipation	P_D		–	–	550	mW

Bus Timing Characteristics: ($V_{CC} = 5V \pm 5\%$, $V_{SS} = 0$, $T_A = 0^\circ$ to $+70^\circ C$ unless otherwise specified)

Parameter	Symbol	Test Conditions	Min	Typ	Max	Unit
Enable Cycle Time	t_{cycE}		1000	–	–	ns
Enable Pulse Width, High	PW_{EH}		450	–	–	ns
Enable Pulse Width, Low	PW_{EL}		430	–	–	ns
Enable Pulse Rise and Fall Times	t_{Er} , t_{Ef}		–	–	25	ns

Bus Timing Characteristics (Cont'd): ($V_{CC} = 5V \pm 5\%$, $V_{SS} = 0$, $T_A = 0^\circ$ to $+70^\circ\text{C}$ unless otherwise specified)

Parameter	Symbol	Test Conditions	Min	Typ	Max	Unit
Setup Time, Address and R/W Valid to Enable Positive Transition	t_{AS}		160	–	–	ns
Address Hold Time	t_{AH}		10	–	–	ns
Data Delay Time, Read	t_{DDR}		–	–	320	ns
Data Hold Time, Read	t_{DHR}		10	–	–	ns
Data Setup Time, Write	t_{DSW}		195	–	–	ns
data Hold Time, Write	t_{DHW}		10	–	–	ns

Peripheral Timing Characteristics: ($V_{CC} = 5V \pm 5\%$, $V_{SS} = 0$, $T_A = 0^\circ$ to $+70^\circ\text{C}$ unless otherwise specified)

Parameter	Symbol	Min	Max	Unit
Peripheral Data Setup Time	t_{PDSU}	200	–	ns
Peripheral Data Hold Time	t_{PDH}	0	–	ns
Delay Time, Enable negative transition to CA2 negative transition	t_{CA2}	–	1.0	μs
Delay Time, Enable negative transition to CA2 positive transition	t_{RS1}	–	1.0	μs
Rise and fall Times for CA1 and CA2 input signals	t_r, t_f	–	1.0	μs
Delay Time from CA1 active transition to CA2 positive transition	t_{RS2}	–	2.0	μs
Delay Time, Enable negative transition to Peripheral Data Valid	t_{PDW}	–	1.0	μs
Delay Time, Enable negative transition to Peripheral CMOS Data Valid PA0 – PA7, CA2	t_{CMOS}	–	2.0	μs
Delay Time, Enable positive transition to CB2 negative transition	t_{CB2}	–	1.0	μs
Delay Time, Peripheral Data Valid to CB2 negative transition	t_{DC}	20	–	ns
Delay Time, Enable positive transition to CB2 positive transition	t_{RS1}	–	1.0	μs
Peripheral Control Output Pulse Width, CA2/CB2	PW_{CT}	550	–	ns
Rise and Fall Time for CB1 and CB2 input signals	t_r, t_f	–	1.0	μs
Delay Time, CB1 active transition to CB2 positive transition	t_{RS2}	–	2.0	μs
Interrupt Release Time, \overline{IRQA} and \overline{IRQB}	t_{IR}	–	2.0	μs
Interrupt Response Time	t_{RS3}	–	1.0	μs
Interrupt Input Pulse Width	PW_I	500	–	ns
Reset Low Time (Note 2)	t_{RL}	1.0	–	μs

Note 2. The Reset line must be high a minimum of $1.0\mu\text{s}$ before addressing the PIA.

Expanded Block Diagram

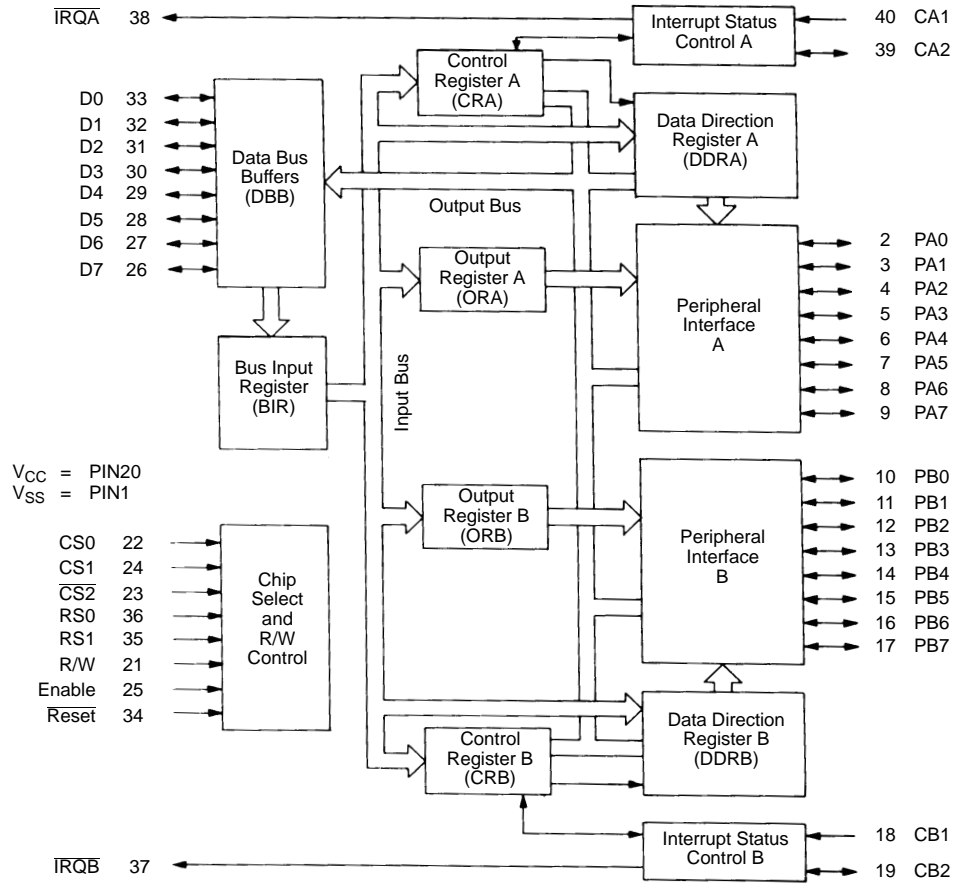

Pin Connection Diagram

