

E-T-A® Thermal Overcurrent Circuit Breakers 104/105/106-...

Description

Miniaturised single pole thermal circuit breaker with push-to-reset tease free, trip-free, snap action mechanism (R-type TO CBE to EN 60934). Available in versions for PCB or panel mounting, snap-in or threadneck, or as an integral type. Approved to CBE standard EN 60934 (IEC 934). For higher current ratings see type 1140.

Typical applications

Motors, transformers, solenoids, printed circuit boards, hand-held machines and appliances.

Ordering information

Type No.	
104	PCB mounting type (-PR), or integral type (-P30/P10)
105	snap-in panel mounting
106	threadneck panel mounting with hex and knurled nut *
106-M1	threadneck mounting for standard fuseholder cutout *
Terminal design	
P10	blade terminals A6.3-0.8
P30	blade terminals A2.8-0.8
PR	solder terminal pins for PCB mounting (type 104 only)
Shunt terminal (optional)	
A3	same as main terminals (up to I_N 6 A/3 A max. load)
Auxiliary contacts (optional)	
Si51	type 104 only
Current ratings	
0.05...10 A	

106 - P30 - [] - [] - 5 A = ordering example

The exact part number required can be built up from the table of choices shown above. Ordering references for optional features should be omitted if not required.

* mounting hardware bulk shipped

Please enquire for packaging quantities

Standard current ratings and typical internal resistance values

Current rating (A)	Internal resistance (Ω)	Current rating (A)	Internal resistance (Ω)
0.05	285	1.8	0.28
0.08	134	2	0.25
0.1	81	2.5	0.18
0.2	22	3	0.11
0.3	8.7	3.5	0.076
0.4	5.5	4	0.067
0.5	3.3	4.5	0.051
0.6	2.45	5	≤ 0.05
0.7	1.6	6	≤ 0.05
0.8	1.45	7	≤ 0.05
1	0.9	8	≤ 0.05
1.2	0.6	10	≤ 0.05
1.5	0.4		

Approvals

Authority	Voltage ratings	Current ratings
VDE (EN 60934), SEV	AC 240 V	0.05...8 A
	DC 48 V	0.05...10 A
Demko	AC 250 V, DC 28 V	0.05...10 A
CSA, UL	AC 250 V, DC 48 V	0.05...10 A
Semko	AC 250 V, DC 48 V	0.1...10 A
Kema (EN 60934)	AC 240 V	0.05...8 A
	DC 48 V	0.05...10 A

Circuit breakers with -Si51 not approved

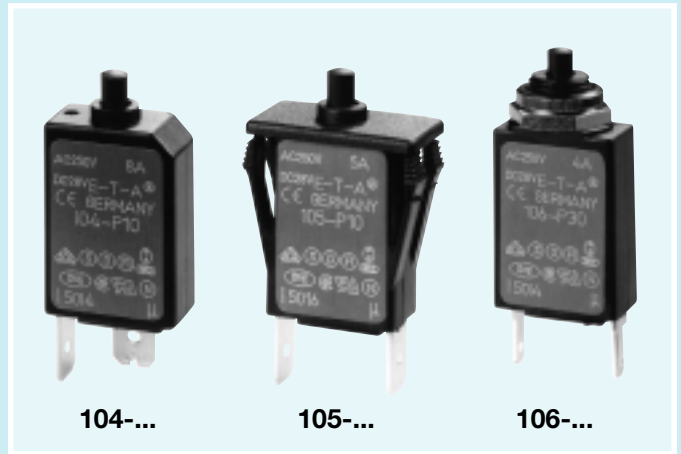

Technical data

Voltage rating	AC 240 V; DC 48 V		
Current ratings	0.05...10 A		
Auxiliary circuit	0.5 A, AC 240 V, DC 28 V		
Typical life	0.05...5 A:	3,000 operations at $2 \times I_N$	
	6...8 A:	500 operations at $2 \times I_N$	
	10 A:	50 operations at $2 \times I_N$	
Ambient temperature	-20...+60 °C (T 60)		
Insulation co-ordination (IEC 664 and 664 A)	Rated impulse withstand voltage	Pollution degree	
	2.5 kV	2	
	reinforced insulation in operating area		
Dielectric strength (IEC 664 and 664A) operating area	Test voltage		
	AC 3,000 V		
Insulation resistance	>100 M Ω (DC 500 V)		
Interrupting capacity I_{cn}	0.05 ... 2 A	6 x I_N	
	2.5 ...10 A	5 x I_N	
Interrupting capacity (UL 1077)	I_N	U_N	
	0.05...4.5 A	AC 250 V	200 A
	5 A	AC 250 V	1000 A
	6...10 A	AC 250 V	2000 A
	0.05...10 A	DC 48 V	200 A
Degree of protection (IEC 529/DIN 40050)	operating area	IP 40	
	terminal area	IP 00	
Vibration	10 g (57-500 Hz), ± 0.76 mm (10-57 Hz), to IEC 68-2-6, test Fc, 10 frequency cycles/axis		
Shock	25 g (11 ms) to IEC 68-2-27, test Ea		
Corrosion	96 hours at 5 % salt mist, to IEC 68-2-11, test Ka		
Humidity	240 hours at 95 % RH, to IEC 68-2-3, test Ca		
Mass	approx. 10 g		

Dimensions

104-PR

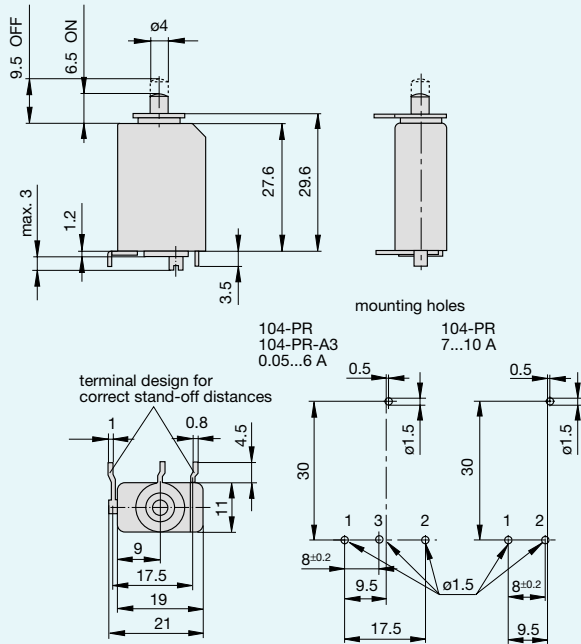

104-P30

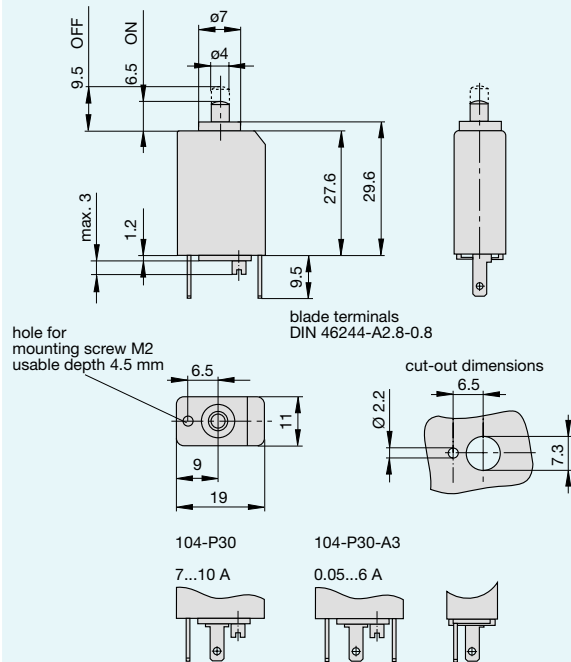

104-PR-(A3)-Si51

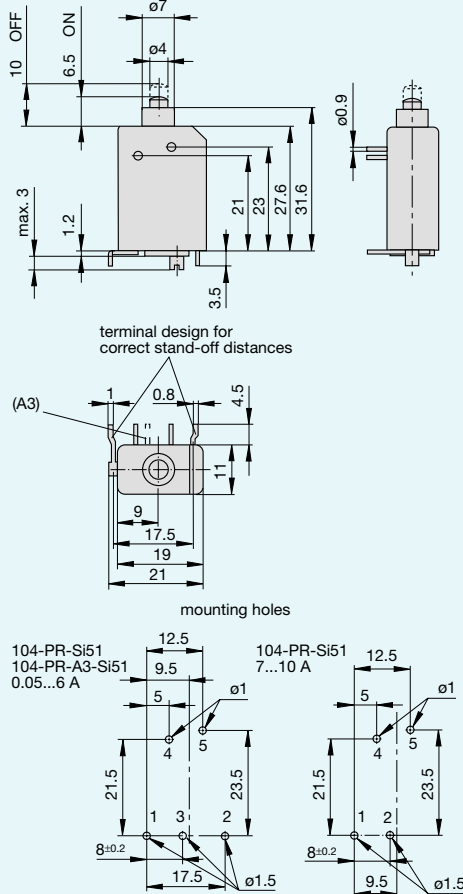

105-P30

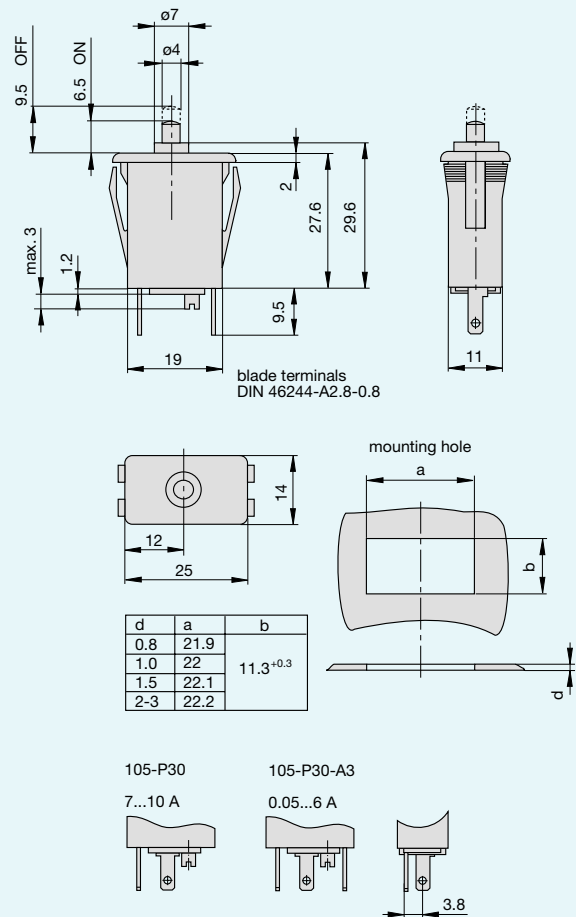

Dimensions

106-P30

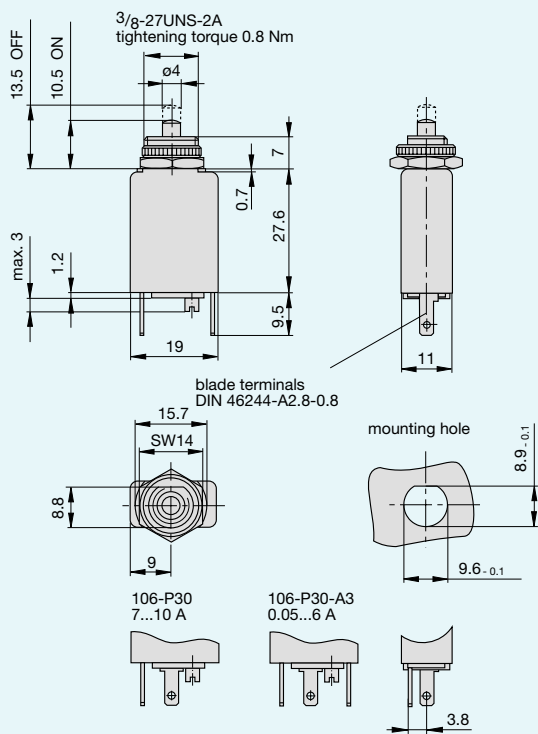

106-M1

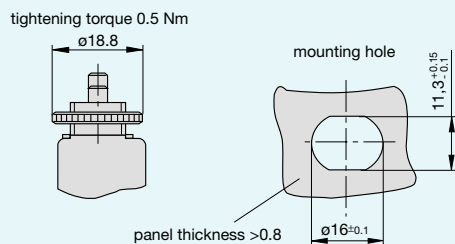

Installation drawings

104-...

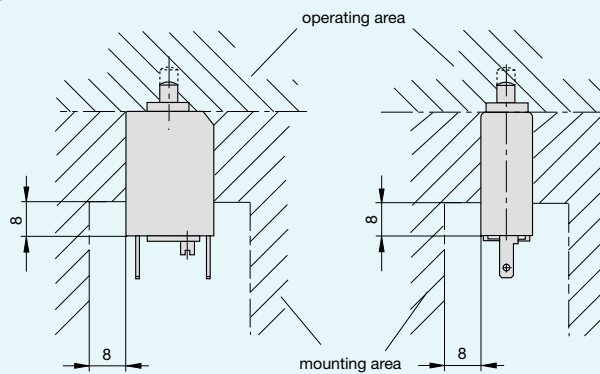

105-...

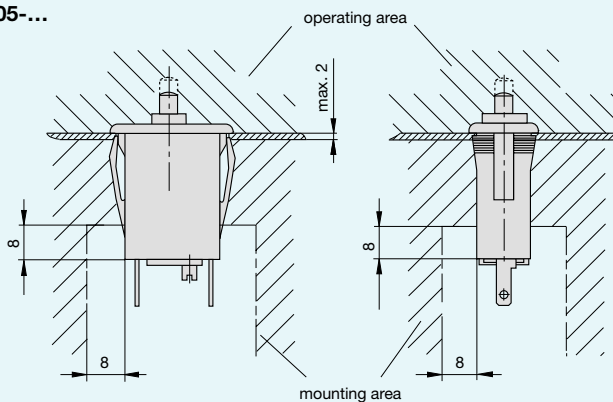

106-...

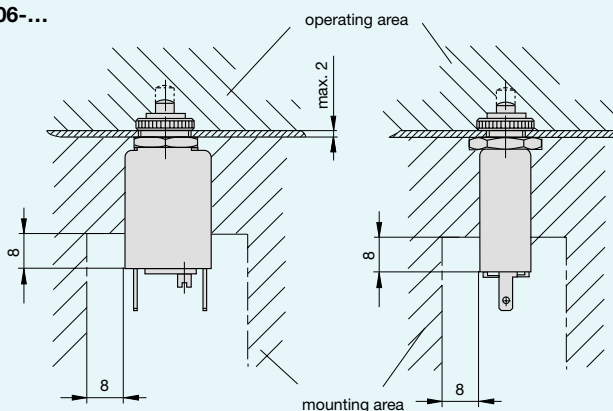

Internal connection diagrams

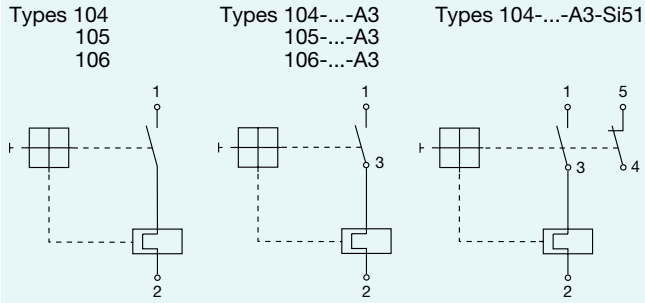

Typical time/current characteristics at +23 °C

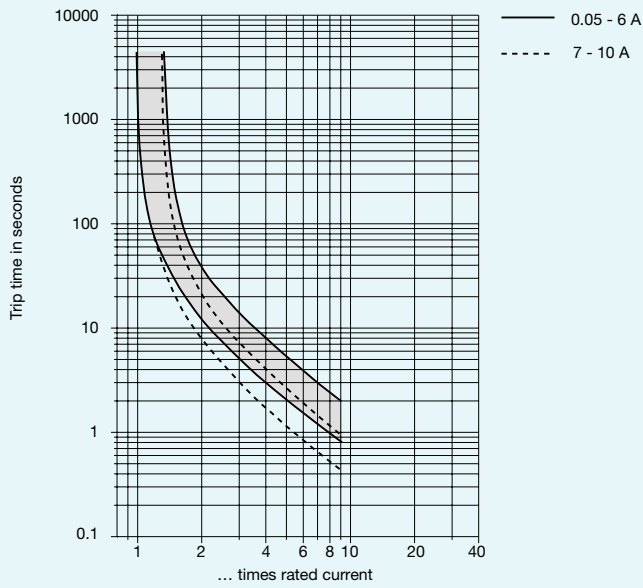

The time/current characteristic curve depends on the ambient temperature prevailing. In order to eliminate nuisance tripping, please multiply the circuit breaker current ratings by the derating factor shown below. See also section 9 – Technical information.

Ambient temperature °C	-20	-10	0	+23	+40	+50	+60
Multiplication factor	0.76	0.84	0.92	1	1.08	1.16	1.24

Terminal design

104/105/106-P10

0.05...6 A

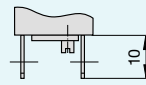

7...10 A

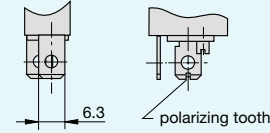

104/105/106-P10-A3

0.05...6 A

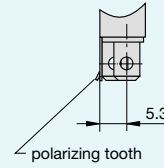

blade terminals
DIN 46244-A6.3-0.8

104/105/106-P30-A3

0.05...6 A

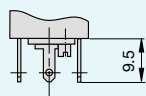

Accessories

Water splash cover (transparent)/knurled nut assembly
(type 106-... only)

X 201 285 01

Degree of protection IP 64

