

"KNA3-XS" safety relay (22.5 mm)

- "Emergency stop" and "mobile guard monitoring" functions
- "CE" conforming product / BG approved
- Control device with one or two channels
- Safety via redundancy and self-checking
- 3 "N/O" safety contacts with linked contacts - 6 A / 250 ~
- 1 "N/C" signalling contact
- Can be used to obtain level 3 according to NF.EN 954-1

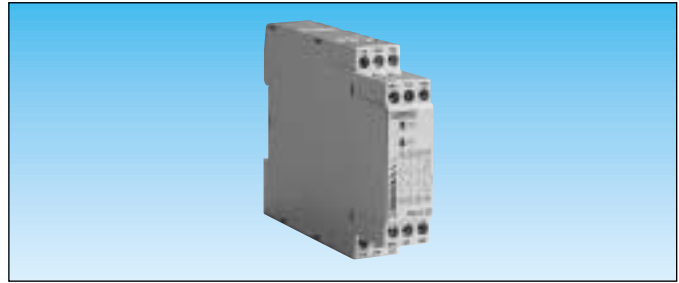

Technical characteristics

Power supply

Power supply voltage	~ 24 V 50/60 Hz = 24 V max. ripple 10%
Operating range	-15% / +10% of Un for ~ -15% / +15% of Un for =
On/off indication	1 power supply voltage LED

Accuracy

Reset time	< 25 ms
Maximum response time on emergency stop	< 50 ms

Output specification

Type	Volt-free outputs
No. of safety circuits	3 "N/O" AgSnO ₂ contacts
No. of data circuits	1 "N/C" AgSnO ₂ contacts
Breaking capacity	1500 VA resistive
Max. current breaking capacity	6.82 A
Max. voltage breaking capacity	440 VAC
Electrical life	10 ⁵ operations at 1500 VA resistive 5.10 ⁵ operations at 500 VA resistive
Mechanical life	10 ⁷ operations

Operation and use

Max. absorbed power	AC 1.6 VA / DC 2 W
On/off indication	1 internal relay status LED
Operating temperature	0°C to +50°C acc. to IEC 68-2-14
Storage temperature	-20°C to +70°C acc. to IEC 68-1/2
Internal voltage	24 V=
Dielectric strength	2.95 kV according to IEC 664-1
Resistance to tracking	Material group III

EMC immunity according to EN 50082-2

Rapid transients	2 kV directly acc. to IEC 1000.4.4 2 kV when coupled
Radiated electromagnetic field	10 V/m Level 3 acc. to IEC 1000.4.3 80 MHz to 1 GHz / 900 MHz (ENV 50140/204)
Electrostatic discharges	8 kV in the air acc. to IEC 1000.4.2
Shock waves	Common mode 1 kV according to IEC1000.4.5
Radio frequencies in common mode	10 V rms Level 3 according to IEC 1000.4.6 150 kHz to 80 MHz (ENV 50141) according to IEC 1000.4.11
Drop-out / short breaks / microbreaks	Un-30% for 10 ms every 1 s Un-60% for 100 ms every 1 s according to IEC 61496-1/97 Un-100% for 10 ms every 100 ms*

* the device operates normally

** the device has not failed dangerously

Casing

Material	Polycarbonate Self-extinguishing - UL94 class VO
Degree of protection	Casing : IP40 Terminal : IP20
Terminal capacity	2 X 1.5 mm ² multicore with ferrule 2 X 2.5 mm ² solid conductor
Weight	310 g

Type

KNA3-XS

Part number (and voltage)

24 V ~/=-	85 100 036
40/260 V ~	* 85 100 037

Conformity

European "Machinery" Directive 89/392/EEC	●
French Decree 92/765-766-768	●
European "Usage" Directive 89/655/EEC	●
French Decree 93-40 / 93-41	●
NF-EN 60204-1	●
NF-EN 292-1 and 2	●
NF-EN 954-1	● Category 3
NF-EN 418	●
NF-EN 1088	●
UL 508	● UL
C22-2 No. 14-M91	● (C) UL
GS-ET-20	● BG

*Available 2nd half 1999

Connections

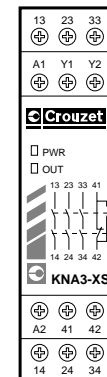

Key

A1-A2	: Power supply Control device(s)
Y1-Y2	: Start / validation
13-14/23-24/33-34	: "N/O" safety contacts
41-42	: "N/C" signalling contacts

To order, specify :

Standard products

1 Part number

Example : KNA3-XS safety relay : 85 100 036

Control devices :

Depending on the degree of safety required, KNA3-XS can receive the following components as inputs :

- emergency stop pushbuttons with one or two contacts (A1-A2)
- position sensors (limit switches) with one or two contacts (A1-A2)
- pushbutton for start or validation (Y1-Y2)

A positive break operation device must be used if a single channel is used. (diagram 1)

To increase the degree of safety, one "N/C" auxiliary contact per power contactor is wired in series with the start (or validation) pushbutton, to ensure self-checking in this part of the installation. (diagram 2)

Control devices :

The KNA3-XS has three "N/O" safety contacts (13-14/23-24/33-34) and one "N/C" signalling contact (41-42). One or more control devices may be wired (diagram 1 and 2) up to the breaking capacity of the safety contacts : 1500 VA. However, to limit internal heating in the KNA3-XS, it is advisable not to exceed 10 A thermal for all three contacts. The signalling contact cannot be used as a safety contact. The signalling contact can be wired on a PLC input or integrated into a fault signalling system.

Extending the number of contacts :

The number of contacts of the KNA3-XS can be extended and the breaking capacity thus increased. To do this, use the KZE3-XS (see page 11/20).

Examples of use

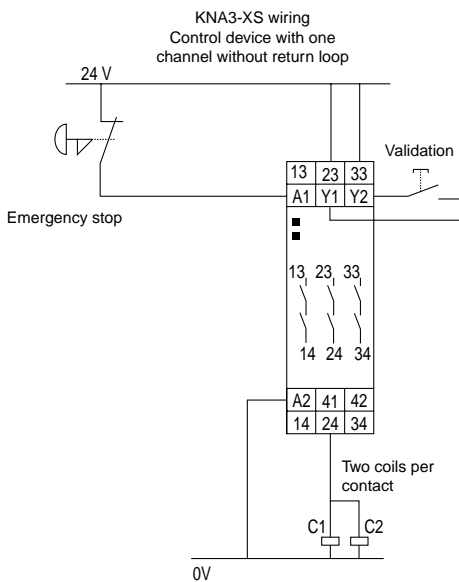

Diagram 1

KNA3-XS wired as category 2

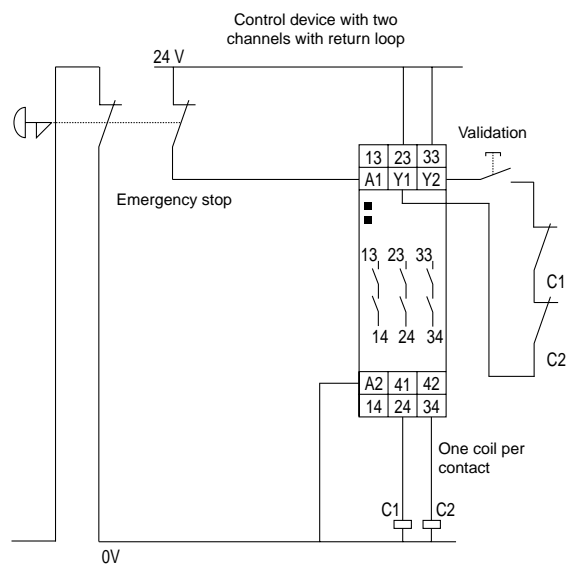
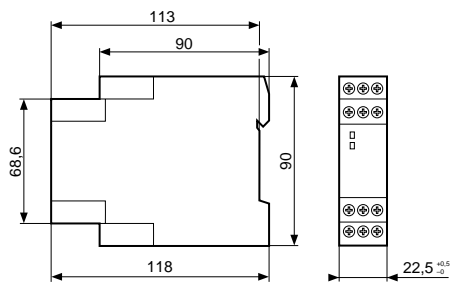

Diagram 2

KNA3-XS wired as category 3

Dimensions



Mounting - Removing

