

## SDP1108

### Low Range Differential Pressure Sensor with fast response time

- For medical ventilators (ICU and home care)
- High sensitivity below 10 Pa to measure small volume flow (neonatal)
- Fast response time for efficient trigger function
- Unsurpassed performance thanks to CMOSens® technology
- Offset and hysteresis free
- Fully calibrated and temperature compensated
- Not sensitive to the mounting orientation and vibrations



Data Sheet – v1.0

### SDP1108 Product Summary

The SDP1108 is a differential pressure sensor for air based on the successful SDP1000/ SDP2000 sensor from Sensirion AG. The response time of the SDP1108 has been optimized for medical ventilation applications.

Mounted in a rugged, chemically inert PPS housing the SDP1108 differential pressure sensors feature a unique dynamic range, zero offset and unsurpassed **long term stability**. This makes it an ideal fit for demanding yet cost sensitive OEM applications in medical and HVAC equipment.

The SDP1108 is fully RoHS compliant.

The SDP1108 is supplied with **5.0 V** and provides a **0.25...4.0 V output**. Although the output of the sensor is analog, the internal linearization and **temperature compensation** is performed digitally. This results in a

superior accuracy, outstanding resolution (up to 0.05 Pa), and lowest temperature dependence.

Its leading performance is based on Sensirion's proprietary CMOSens® sensor technology which combines the sensor element with amplification and A/D conversion on one single silicon chip. The differential pressure is measured by a thermal sensing element. In contrast to other thermal differential pressure sensors only a very small amount of air is required. This leads to a reliable operation even under harsh conditions. In comparison to membrane and piezo-resistive based sensors the SDP1108 differential pressure sensors show an extended measurement range, better **offset stability** and improved reproducibility even at lowest pressure ranges. In addition the SDP1108 is robust against pressure bursts and shows no sensitivity to the mounting orientation.

### Applications

Medical applications:

- Homecare ventilation
- Intensive care ventilation (ICU)
- Other

### Block Diagram

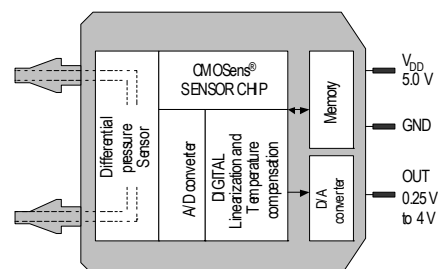

## 1 Sensor Output Characteristics<sup>1</sup>

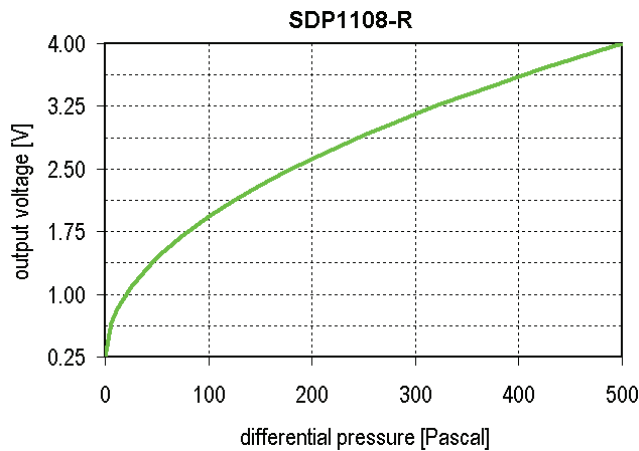

The SDP1108-R provides a fully calibrated voltage output. To enhance resolution and accuracy at very low differential pressures, the SDP1108 standard version (SDP1108-R) comes with a root-square output characteristics.

For high-quantity OEM applications, other ranges and output characteristics can be realized. E.g. linear output and a bidirectional measurement range is possible. Please contact Sensirion for further information.

$$\text{Differential\_Pressure}[\text{Pa}] = \left( \frac{\text{Output\_Voltage} - 0.25\text{V}}{3.75\text{V}} \right)^2 \cdot 500\text{Pa}$$

Use this formula to convert the sensor output into physical value.

<sup>(1)</sup>Calibration conditions apply unless otherwise noted: 23°C and  $p_{\text{absolute}} = 966 \text{ mbar}$ , dry air,  $V_{\text{DD}} = 5.000 \text{ V}$

## 2 Specifications

Table 1: SDP1108-R Sensor specifications<sup>(1)</sup>

Parameter		SDP1108-R			Unit
		Min	Typ	Max	
Measurement range		0.25	-	4	Volts
		0	-	500	Pa
		0	-	2	Inch water
Accuracy <sup>(3)</sup>	100 to 500 Pa	-	1.0	2.0	% Measured Value <sup>(4)</sup>
	0 to 100 Pa	-	0.2	0.4	% Full Span <sup>(5)</sup>
	zero <sup>(2)</sup>	-	15 0.01	40 0.06	mV Pa
Repeatability	100 to 500 Pa	-	0.3	1.0	% Measured Value
	0 to 100 Pa	-	0.05	0.2	% Full Span <sup>(5)</sup>
Null drift per year <sup>(6)</sup>		-	0	0.1	Pa / year
Additional error over temperature <sup>(7)</sup> ( $T \neq 23^\circ\text{C}$ )	0 to 500 Pa	-	0.03	0.05	% Measured Value / °C <sup>(4)</sup>
	zero	-	1	2	mV/°C
Response time <sup>(8)</sup>		6.6	8.0	10.1	Ms
Cut off frequency of internal filter		17	20	24	Hz

<sup>(1)</sup> Calibration conditions apply unless otherwise noted: 23°C and  $p_{\text{absolute}} = 966 \text{ mbar}$ , dry air,  $V_{\text{DD}} = 5.000 \text{ V}$

<sup>(2)</sup> Variance between the zero point (offset) of different sensors measured under the same conditions (e.g. same supply voltage, temperature, ...)

<sup>(3)</sup> Include deviations due to linearity, hysteresis, and repeatability

<sup>(4)</sup> % measured value = (SDP1108 output [Pa] - output of reference instrument [Pa]) / output of reference instrument [Pa].

<sup>(5)</sup> Full span = 3750mV or 500 Pa

<sup>(6)</sup> Drift over time due to aging, pressure cycles... Test results can be provided.

<sup>(7)</sup> The additional error due to temperature variation is temporary. Once the sensor is back to the calibration temperature, the shift disappears (no hysteresis).

<sup>(8)</sup> Tau= 0 to 63%, filter response time = 8ms. For faster response time, contact Sensirion.

Table 2: Additional sensor specifications.

Parameter			
Media	Air, N <sub>2</sub> – for other gases contact Sensirion AG.		
Operating Conditions: - Temperature - Humidity	-10 °C ... +60 °C / 14°F ... 140 °F non-condensing		
Ambient storage conditions <sup>1</sup>	-40 °C ... +80 °C / -40°F ... 176 °F		
Position sensitivity	below resolution		
Admissible overpressure (short term)	1 bar (14.5 PSI)		
Burst Pressure Capability	2 bar (29 PSI)		
Weight	14 g		
Protection Class	IP 20		
Wetted materials	Glass (silicon nitride, silicon oxide), Silicon, PPS (Polyphenylene Sulfide), PEEK (Polyetheretherketone), FR4, Silicone as static sealing, Epoxy, Gold		
Electromagnetic compatibility	EN 61000-4-2	Air discharge (ESD)	± 2 kV
	EN 61000-4-3	High frequency electromagnetic radiation (HF)	3 V/m
	EN 61000-4-4	Fast transients (burst)	± 4 kV
Lead free	ROHS compliant.		

<sup>(1)</sup>For maximum 2 weeks

## 2.1 Temperature Compensation

The SDP1108 differential pressure sensor features a sophisticated built-in temperature compensation circuit. The temperature is measured on the CMOSens® chip by means of a PTAT bandgap reference temperature sensor. Its data is fed into a compensation circuit which is also integrated on the CMOSens® sensor chip. No external temperature compensation is therefore required.

## 2.2 Altitude Correction

The SDP1108 differential pressure transducer achieves its unsurpassed performance by using a dynamic measurement principle: An applied differential pressure forces a small air flow through the SDP1108, which measures this air flow.

The sensor signal is dependant on the ambient air density. The temperature effect on density is compensated by internal intelligence (see Paragraph 2.3). Effects on density due to a change of ambient pressure, typically a change of altitude above sea level, can be compensated using a correction factor according to the following equation:

$$Dp_{\text{eff}} = Dp_{\text{sensor}} \cdot P_{\text{cal}} / P_{\text{amb}}$$

where  $Dp_{\text{eff}}$  is the effective differential pressure,  $Dp_{\text{sensor}}$  the differential pressure indicated by the SDP1108,  $P_{\text{cal}}$

the absolute pressure during calibration (966 mbar) and  $P_{\text{amb}}$  the actual ambient absolute pressure. This leads to the following correction factors:

Table 3: Altitude correction factors.

Altitude [meter]	Ambient Pressure ( $P_{\text{amb}}$ ) [mbar]	Correction Factor $P_{\text{cal}} / P_{\text{amb}}$
0	1013	0.95
250	984	0.98
425	966	1.00
500	958	1.01
750	925	1.04
1500	842	1.15
2250	766	1.26
3000	697	1.38

Example:

The SDP1108 is used at 750 m above sea level. The output of the SDP1108 shows 0.5 V, which corresponds to  $Dp_{\text{sensor}} = 33.3$  Pa. Taking into account the correction factor  $P_{\text{cal}} / P_{\text{amb}} = 1.04$  the effective differential pressure  $Dp_{\text{eff}}$  is  $33.3 \text{ Pa} \cdot 1.04 = 34.6$  Pa.

Note:

In many medical and HVAC applications such as filter monitoring, fan/ventilator control or air flow measurement the described effect is actually welcome since at the end the mass flow and not volume flow is the effective value to control.

### 3 Physical Dimensions and Mounting Information

#### 3.1 Housing

The SDP1108 differential pressure transducer is mounted in chemically inert PPS housing. The rugged package has been designed to withstand continuous overpressures of at least 1 bar (14.5 PSI). Burst pressure is > 2 bar (29 PSI)

The physical dimensions and mounting information is given in Figure 1 and 2.

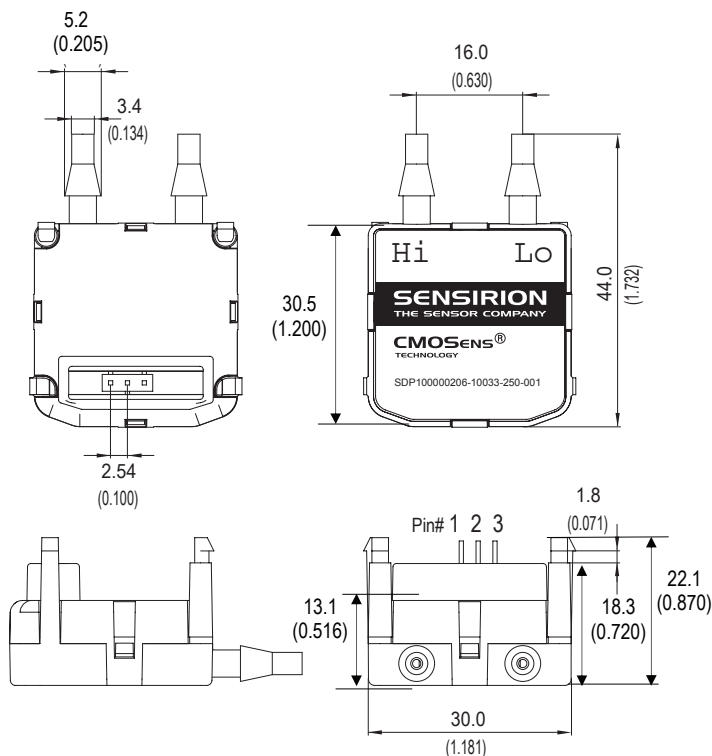

Pin#	Function
1	VDD (5 Vdc)
2	Ground
3	OUT (0.25...4 Vdc)

Figure 1: Pin out and physical dimensions in mm (inch). The drawing is not to scale.

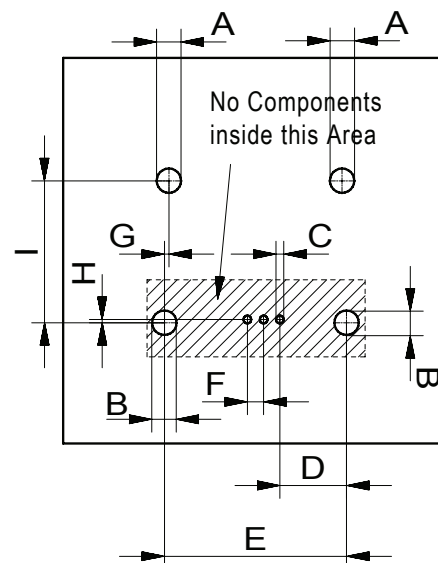

Dim.	[mm]	[inch]	[mil]
A	3.00	0.118	118
B	3.30	0.130	130
C	1.20	0.047	47
D	10.20	0.402	402
E	28.20	1.110	1110
F	2.54	0.100	100
G	0.60	0.024	24
H	0.50	0.020	20
I	22.70	0.894	894

Figure 2: SDP1108 PCB footprint. The drawing is not to scale.

#### 3.2 Soldering Instructions

The SDP1108 differential pressure sensor can be wave soldered. Direct reflow soldering is not recommended since it may affect the accuracy.

If reflow soldering is required Sensirion recommends to use an SMD connector (e.g. type Samtec SSM-103-L-SV) and to mount the SDP1108 after soldering.

### 3.3 Connecting Hose

Sensirion recommends a hose with an inner diameter of 1/8 to 3/20 inch (3.18 to 3.8mm). Due to the dynamic measurement principle, a small air flow is required (Figure 3) which leads to a dependence on the length

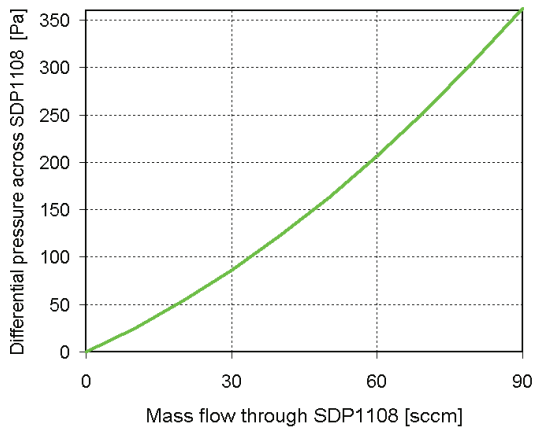

Figure 3: Typical air flow through the SDP1108.  
Please note: 1 scc/min = 1 cm<sup>3</sup>/min at 0°C and 1013 mbar pressure (1 sccm = 0.001 norm liter).

of the hose (Figure 4). Tubes up to 1 m show less than 1 % error of the measured value (Figure 4).

Length of the connecting hose	Deviation of Measured Value
0.5 m (20 inch)	- 0.4 %
1.0 m (40 inch)	- 0.8 %
2.0 m (80 inch)	- 1.6 %
4.0 m (160 inch)	- 3.2 %

Figure 4: Influence of the length of the connecting hose on the accuracy (using 3/16 inch inner diameter). Example: a 50 Pa difference pressure is shown as 49.8 Pa when using 0.5 m tube with 3/16 inch diameter.

## 4 Electrical Specifications

### 4.1 Power Supply

The SDP1108 differential pressure sensors require a stable voltage supply of 5.0 V. Influence of the supply voltage variation on the offset and the sensitivity are given in Table 5.

### 4.2 Voltage Output

The SDP1108 features a voltage output from 0.25 V to 4.0 V. An output voltage below 0.25 V indicates a negative differential pressure (not calibrated). The resistive load at the output pin should be larger than 20 kOhm. The capacitive load at the output pin must not be larger than 200 pF. If the design shows a larger capacity at the output pin an additional resistor is required in series at the output (e.g. 620 Ohm).

Table 4: SDP1108 electrical characteristics.

Parameter	Conditions	Min.	Typ.	Max.	Units
Power Supply Voltage $V_{DD}$		4.75	5.0	5.25	VDC
Operating Current	5 V, no load, zero flow		5.1	6	mA
Output capacitive load $C_{load}$			20	200	pF
Recommended load $R_{load}$		20	100	$\infty$	k $\Omega$

## 5 Ordering Information

When ordering please refer to the following part names and article numbers. For the latest product information and local distributor check out Sensirion's website on <http://www.sensirion.com>

Part Name	Article Number
SDP1108-R	1-100339-01

## Important Notices

### Warning, personal injury

**Do not use this product as safety or emergency stop devices or in any other application where failure of the product could result in personal injury (including death). Do not use this product for applications other than its intended and authorized use. Before installing, handling, using or servicing this product, please consult the data sheet and application notes. Failure to comply with these instructions could result in death or serious injury.**

If the Buyer shall purchase or use SENSIRION products for any unintended or unauthorized application, Buyer shall defend, indemnify and hold harmless SENSIRION and its officers, employees, subsidiaries, affiliates and distributors against all claims, costs, damages and expenses, and reasonable attorney fees arising out of, directly or indirectly, any claim of personal injury or death associated with such unintended or unauthorized use, even if SENSIRION shall be allegedly negligent with respect to the design or the manufacture of the product.

### ESD Precautions

The inherent design of this component causes it to be sensitive to electrostatic discharge (ESD). To prevent ESD-induced damage and/or degradation, take customary and statutory ESD precautions when handling this product.

See application note "ESD, Latchup and EMC" for more information.

### Warranty

SENSIRION warrants solely to the original purchaser of this product for a period of 12 months (one year) from the date of delivery that this product shall be of the quality, material and workmanship defined in SENSIRION's published specifications of the product. Within such period, if proven to be defective, SENSIRION shall repair and/or replace this product, in SENSIRION's discretion, free of charge to the Buyer, provided that:

- notice in writing describing the defects shall be given to SENSIRION within fourteen (14) days after their appearance;
- such defects shall be found, to SENSIRION's reasonable satisfaction, to have arisen from SENSIRION's faulty design, material, or workmanship;
- the defective product shall be returned to SENSIRION's factory at the Buyer's expense; and
- the warranty period for any repaired or replaced product shall be limited to the unexpired portion of the original period.

This warranty does not apply to any equipment which has not been installed and used within the specifications recommended by SENSIRION

for the intended and proper use of the equipment. EXCEPT FOR THE WARRANTIES EXPRESSLY SET FORTH HEREIN, SENSIRION MAKES NO WARRANTIES, EITHER EXPRESS OR IMPLIED, WITH RESPECT TO THE PRODUCT. ANY AND ALL WARRANTIES, INCLUDING WITHOUT LIMITATION, WARRANTIES OF MERCHANTABILITY OR FITNESS FOR A PARTICULAR PURPOSE, ARE EXPRESSLY EXCLUDED AND DECLINED.

SENSIRION is only liable for defects of this product arising under the conditions of operation provided for in the data sheet and proper use of the goods. SENSIRION explicitly disclaims all warranties, express or implied, for any period during which the goods are operated or stored not in accordance with the technical specifications.

SENSIRION does not assume any liability arising out of any application or use of any product or circuit and specifically disclaims any and all liability, including without limitation consequential or incidental damages. All operating parameters, including without limitation recommended parameters, must be validated for each customer's applications by customer's technical experts. Recommended parameters can and do vary in different applications.

SENSIRION reserves the right, without further notice, (i) to change the product specifications and/or the information in this document and (ii) to improve reliability, functions and design of this product.

### Bare Die Disclaimer

All die are tested and calibrated and are guaranteed to comply with all data sheet limits. Only random sample tests are performed on individual die. SENSIRION has no control of third party procedures in the handling, packing or assembly of the die. Accordingly, SENSIRION assumes no liability for device functionality or performance of the die or systems after third party handling, packing or assembly of the die. It is the responsibility of the customer to test and qualify their application in which the die is used.

Copyright© 2001-2008, SENSIRION.

CMOSens® is a trademark of Sensirion

All rights reserved



## Revision history

Date	Revision	Changes
October	V1.0	Initial release

## Headquarters and Sales Office

SENSIRION AG  
Laubisruetistr. 50  
CH-8712 Staefa ZH  
Switzerland

Phone: + 41 (0)44 306 40 00  
Fax: + 41 (0)44 306 40 30  
[info@sensirion.com](mailto:info@sensirion.com)  
<http://www.sensirion.com/>

SENSIRION Korea Co. Ltd.  
#1414, Anyang Construction Tower B/D,  
1112-1, Bisan-dong, Anyang-city,  
Gyeonggi-Province, South Korea

Phone: +82-31-440-9925~27  
Fax: +82-31-440-9927  
[info@sensirion.co.kr](mailto:info@sensirion.co.kr)  
<http://www.sensirion.co.kr>

SENSIRION Inc  
Westlake Pl. Ctr. I, suite 240  
2801 Townsgate Road  
Westlake Village, CA 91361  
USA

Phone: 805-409 4900  
Fax: 805-435 0467  
[michael.karst@sensirion.com](mailto:michael.karst@sensirion.com)  
<http://www.sensirion.com/>

SENSIRION Japan  
Sensirion Japan Co. Ltd.  
Shinagawa Station Bldg. 7F  
4-23-5 Takanawa  
Minato-ku, Tokyo, Japan

phone: +81 3-3444-4940  
fax: +81 3-3444-4939  
[info@sensirion.co.jp](mailto:info@sensirion.co.jp)  
<http://www.sensirion.co.jp>

Find your local representative at: <http://www.sensirion.com/rep>