

ER cores and accessories

ER9.5

CORE SETS

Effective core parameters

SYMBOL	PARAMETER	VALUE	UNIT
$\Sigma(l/A)$	core factor (C1)	1.67	mm ⁻¹
V_e	effective volume	120	mm ³
l_e	effective length	14.2	mm
A_e	effective area	8.47	mm ²
A_{min}	minimum area	7.60	mm ²
m	mass of core half	≈0.35	g

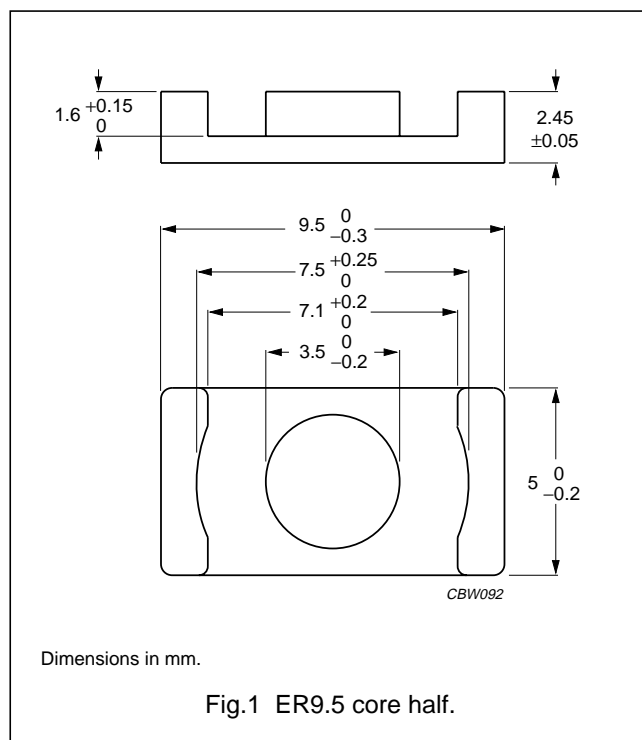

Core sets for general purpose transformers and power applications

Clamping force 10 ± 5 N.

GRADE	A_L (nH)	μ_e	AIR GAP (μm)	TYPE NUMBER
3F3 <small>des</small>	63 $\pm 3\%$	≈84	≈200	ER9.5-3F3-A63-S
	100 $\pm 3\%$	≈133	≈100	ER9.5-3F3-A100-S
	160 $\pm 10\%$	≈213	≈70	ER9.5-3F3-A160-S
	850 $\pm 25\%$	≈1130	≈0	ER9.5-3F3-S
3F4 <small>des</small>	40 $\pm 3\%$	≈53	≈300	ER9.5-3F4-A40-S
	63 $\pm 5\%$	≈84	≈200	ER9.5-3F4-A63-S
	100 $\pm 5\%$	≈133	≈100	ER9.5-3F4-A100-S
	525 $\pm 25\%$	≈700	≈0	ER9.5-3F4-S

Core sets of high permeability grades

Clamping force 10 ± 5 N, flux density $\hat{B} \leq 0.1$ mT.

GRADE	A_L (nH)	μ_e	AIR GAP (μm)	TYPE NUMBER
3E5 <small>des</small>	3600 +40/-30%	≈4780	≈0	ER9.5-3E5-S
3E6 <small>des</small>	4800 +40/-30%	≈6380	≈0	ER9.5-3E6-S

ER cores and accessories

ER9.5

Properties of core sets under power conditions

GRADE	B (mT) at	CORE LOSS (W) at			
	H = 250 A/m; f = 25 kHz; T = 100 °C	f = 100 kHz; B̂ = 100 mT; T = 100 °C	f = 400 kHz; B̂ = 50 mT; T = 100 °C	f = 1 MHz; B̂ = 30 mT; T = 100 °C	f = 3 MHz; B̂ = 10 mT; T = 100 °C
3F3	≥300	≤0.015	≤0.025	–	–
3F4	≥250	–	–	≤0.024	≤0.038

COIL FORMERS

General data

PARAMETER	SPECIFICATION
Coil former material	liquid crystal polymer (LCP), glass reinforced, flame retardant in accordance with "UL 94V-0"; UL file number E54705(M)
Pin material	copper-tin alloy (CuSn), tin-lead alloy (SnPb) plated
Maximum operating temperature	155 °C, "IEC 85" class F
Resistance to soldering heat	"IEC 68-2-20", Part 2, Test Tb, method 1B: 350 °C, 3.5 s
Solderability	"IEC 68-2-20", Part 2, Test Ta, method 1: 235 °C, 2 s

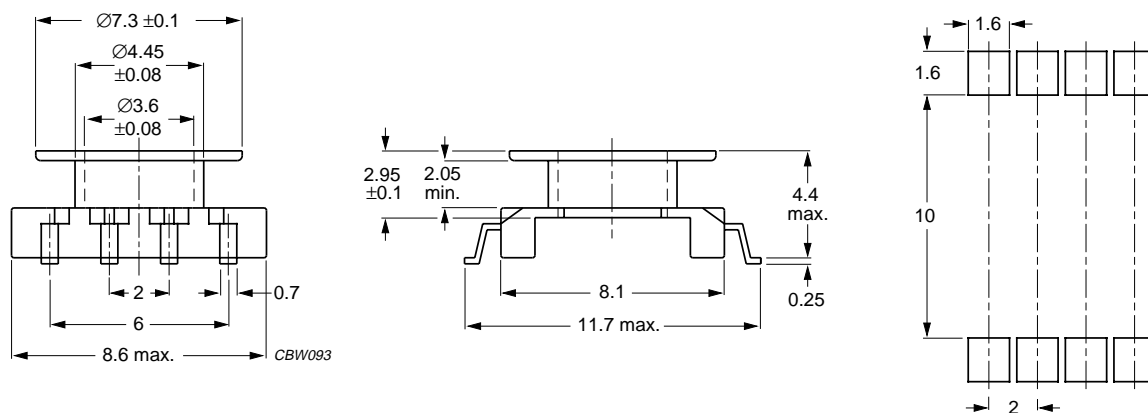

Fig.2 ER9.5 coil former (SMD); 8-solder pads.

Winding data for ER9.5 coil former (SMD) with 8 solder pads

NUMBER OF SECTIONS	WINDING AREA (mm ²)	MINIMUM WINDING WIDTH (mm)	AVERAGE LENGTH OF TURN (mm)	TYPE NUMBER
1	2.8	2.05	18.4	CPVS-ER9.5-1S-8P

ER cores and accessories

ER9.5

MOUNTING PARTS

General data and ordering information

ITEM	REMARKS	FIGURE	TYPE NUMBER
Clamp	stainless steel (CrNi); clamping force ≈ 20 N	3	CLM-ER9.5

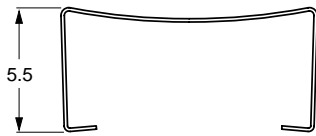
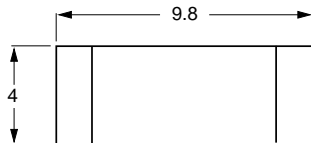

CBW094

Dimensions in mm.

Fig.3 ER9.5 clamp.