

Applications

- Temperature measurement and compensation for mobile phone applications (e.g. battery pack, TCXO, LCD display), automotive and data systems

Features

- Standard EIA chip size 1206
- SMD NTC with Ni - Barrier termination (Ag/Ni/Sn)
- The component is compliant with ROHS (DIRECTIVE 2002/95/EC OF THE EUROPEAN PARLIAMENT AND THE COUNCIL of 27 January 2003 on the restriction of the use of certain hazardous substances in electrical and electronic equipment)
- Suitable for lead-free soldering process

Electrical Specifications

Part Number	Zero-Power Resistance (at 25°C)	B _{25/100}	B _{25/85}	B _{25/50}
B57621C5103*062	10 kΩ	3530 K ± 3%	(3510 K)	(3470 K)

* = Resistance Tolerance: J for $\Delta R/R_{25} = \pm 5\%$
 K for $\Delta R/R_{25} = \pm 10\%$
 M for $\Delta R/R_{25} = \pm 20\%$

Climatic Category (IEC 60068-1)	55/125/21
Lower category temperature	-55°C
Higher category temperature	125°C
Power rating at 25°C	P ₂₅ 300mW¹⁾
Dissipation factor (on PCB)	G _{th} approx. 5 mW/K¹⁾
Thermal cooling time constant (on PCB)	T _{th} approx. 10 s¹⁾
Heat capacity	C _{th} approx. 50 mJ/K¹⁾
Weight of component	approx. 18 mg

¹⁾ Depends on mounting situation

Part Dimensions

Type	L	W	T	k
1206	3.2±0.20	1.60±0.20	1.30 max.	0.50±0.25

Dimensions in mm

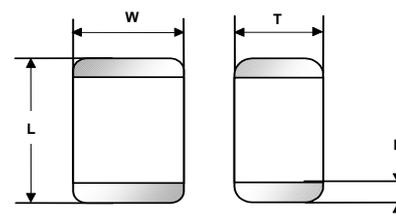

Termination Ag/Ni/Sn Dimensions in [mm]

ISSUE DATE	02.09.05	ISSUE	b	PUBLISHER	KB S PE	PAGE	1/7
------------	----------	-------	---	-----------	---------	------	-----



SMD NTC Thermistor

SMD NTC Thermistor with Ni-Barrier Termination

B57621C5103*062

Data sheet

Resistance - Temperature Characteristic

R at 25°C = 10000 Ω ± 5%

B_{25/100} = 3530 K ± 3%

T [°C]	R_Nom [Ω]	R_Min [Ω]	R_Max [Ω]	ΔR/R25 [±%]	ΔT [±°C]
-55,00	528.264,00	432.778,00	623.751,00	18,10	2,80
-50,00	386.430,00	320.784,00	452.076,00	17,00	2,80
-45,00	285.744,00	240.174,00	331.314,00	15,90	2,70
-40,00	213.457,00	181.540,00	245.374,00	15,00	2,60
-35,00	161.003,00	138.465,00	183.542,00	14,00	2,50
-30,00	122.555,00	106.520,00	138.591,00	13,10	2,40
-25,00	94.071,00	82.588,00	105.554,00	12,20	2,30
-20,00	72.862,00	64.582,00	81.142,00	11,40	2,30
-15,00	56.835,00	50.837,00	62.833,00	10,60	2,20
-10,00	44.698,00	40.329,00	49.067,00	9,80	2,10
-5,00	35.385,00	32.192,00	38.578,00	9,00	2,00
0,00	28.222,00	25.880,00	30.565,00	8,30	1,90
5,00	22.649,00	20.927,00	24.371,00	7,60	1,80
10,00	18.300,00	17.032,00	19.569,00	6,90	1,60
15,00	14.872,00	13.938,00	15.806,00	6,30	1,50
20,00	12.161,00	11.474,00	12.849,00	5,70	1,40
25,00	10.000,00	9.500,00	10.500,00	5,00	1,30
30,00	8.268,00	7.802,00	8.734,00	5,60	1,50
35,00	6.871,00	6.445,00	7.297,00	6,20	1,70
40,00	5.740,00	5.353,00	6.128,00	6,80	1,90
45,00	4.818,00	4.467,00	5.169,00	7,30	2,10
50,00	4.064,00	3.747,00	4.381,00	7,80	2,30
55,00	3.443,00	3.157,00	3.728,00	8,30	2,50
60,00	2.930,00	2.672,00	3.187,00	8,80	2,80
65,00	2.503,00	2.272,00	2.735,00	9,30	3,00
70,00	2.148,00	1.939,00	2.356,00	9,70	3,20
75,00	1.850,00	1.662,00	2.038,00	10,20	3,40
80,00	1.600,00	1.430,00	1.769,00	10,60	3,70
85,00	1.388,00	1.235,00	1.541,00	11,00	3,90
90,00	1.209,00	1.071,00	1.347,00	11,40	4,20
95,00	1.056,00	931,60	1.181,00	11,80	4,40
100,00	926,00	813,10	1.039,00	12,20	4,70
105,00	814,40	712,10	916,70	12,60	4,90
110,00	718,40	625,50	811,30	12,90	5,20
115,00	635,70	551,30	720,20	13,30	5,50
120,00	564,10	487,20	641,00	13,60	5,80
125,00	502,00	431,80	572,10	14,00	6,10



SMD NTC Thermistor

SMD NTC Thermistor with Ni-Barrier Termination

B57621C5103*062

Data sheet

Reliability

Tests of SMD NTC thermistors are made according to IEC 60068. The parts are mounted on standardized PCB in accordance with IEC 60539-1.

Test	Standard	Test conditions	$\Delta R_{25} / R_{25}$ (typical)	Remarks
Storage in dry heat	IEC 60068-2-2 (=JIS C 0021)	Storage at upper category temperature T: 125°C t: 1000h	< 3%	
Storage in damp heat, steady state	IEC 60068-2-3 (=JIS C 0022)	Temperature of air: 40°C relative humidity of air: 93% Duration: 21days	< 3%	No visible damage
Rapid temperature cycling	IEC 60068-2-14 (=JIS C 0025)	Lower test temperature: -55°C Upper test temperature: 125°C Number of cycles: 10	< 3%	
Endurance at P _{max}	-	P _{max} =300mW Duration: 1000h	< 5%	
Solderability	IEC 60068-2-58 (=JIS C 0054)	Solderability: 215°C/3s (Pb-cont. solder) 245°C/3s (Pb-free solder) Resistance to soldering heat: 260°C/10s		95% of termination wetted
Resistance drift after soldering	-	reflow soldering profile wave soldering profile	< 5%	

ISSUE DATE	02.09.05	ISSUE	b	PUBLISHER	KB S PE	PAGE	3/7
------------	----------	-------	---	-----------	---------	------	-----

Mounting Instructions

1. Termination Ni-barrier termination (Ag/Ni/Sn)

2. Recommended geometry of solder pads

Size	A [mm]	B [mm]	C [mm]	D [mm]
1206	1.8	1.2	2.1	4.5

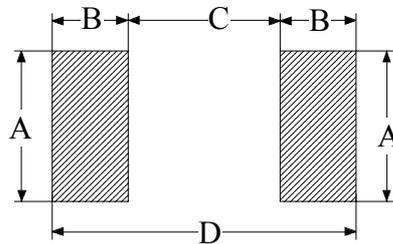

3. Requirements for Solderability

- Wettability test in accordance with IEC 60068-2-58 (= JIS C 0054) :

Preconditioning: Immersion into flux F-SW 32.

Evaluation criteria: Wetting of soldering areas $\geq 95\%$.

Pb-containing solder: *Sn(60)Pb(40)*

Bath temperature (°C): 215 ± 3

Dwell time (s): 3 ± 0.3

Pb-free solder: *Sn(95.1-96.0)Ag(3.0-4.0)Cu(0.5-0.9)*

Bath temperature (°C): 245 ± 5

Dwell time (s): 3 ± 0.3

- Soldering heat resistance test in accordance with IEC 60068-2-58 (= JIS C 0054) :

Preconditioning: Immersion into flux F-SW 32.

Evaluation criteria: Leaching of side edges $\leq 1/3$.

Solder: *Sn(60)Pb(40)*, *Sn(95.1-96.0)Ag(3.0-4.0)Cu(0.5-0.9)*

Bath temperature (°C): 260 ± 5

Dwell time (s): 10 ± 1

4. Recommended soldering profiles

Reflow soldering profile: (according to CECC 00802)

Temperature characteristics at component terminals during reflow soldering (two cycles are permitted).

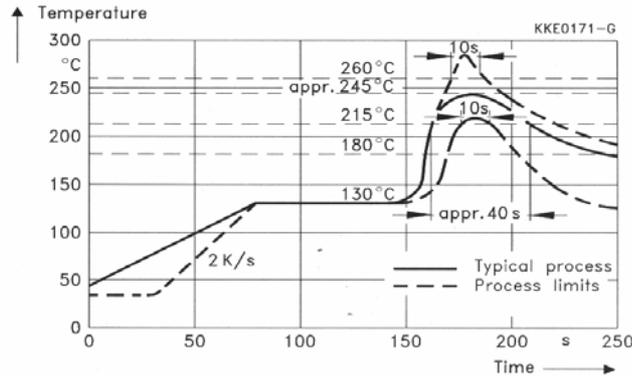

Wave soldering profile:

Temperature characteristics at component terminals during wave soldering can be recommended once in general.

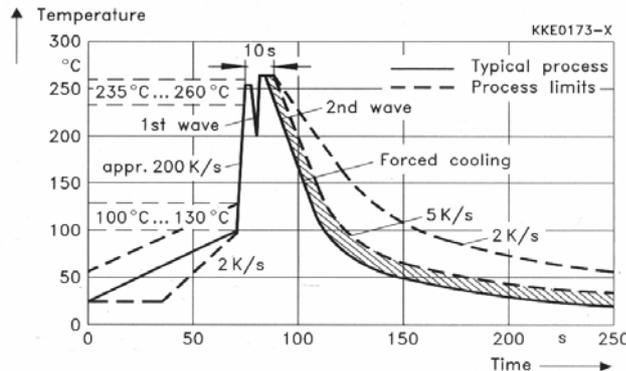

5. Storage conditions

Solderability is guaranteed for 12 months from date of delivery for types with Ni-barrier termination, provided that the components are stored in the original packages.

Storage temperature: -25 ... +45°C

Relative humidity: < 75% annual average, < 95% on max. 30 days in a year, dew precipitation and wetness are inadmissible.

ISSUE DATE	02.09.05	ISSUE	b	PUBLISHER	KB S PE	PAGE	5/7
------------	----------	-------	---	-----------	---------	------	-----

Taping and Packing

Taping:

Tape and reel packing comply with specifications of IEC 60286-3

Blister tape

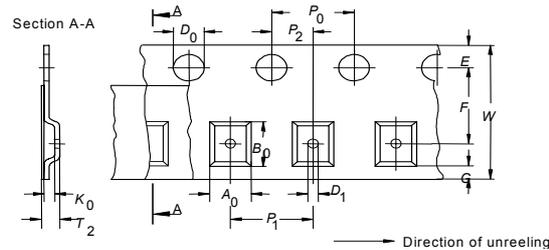

Dimensions and tolerances:

Definition	Symbol	Dimension (mm)	Tol. (mm)
		Size 1206	
Compartment width x Compartments length	$A_0 \times B_0$	1.9 x 3.5	± 0.2
Compartment height	K_0	1.4	max.
Overall thickness	T_2	2.5	max.
Sprocket hole diameter	D_0	1.5	$+0.1/-0$
Compartment hole diameter	D_1	1.0	min.
Sprocket hole pitch	P_0	4.0	$\pm 0.1^{1)}$
Distance centre hole to centre compartment	P_2	2.0	± 0.05
Pitch of the component compartments	P_1	4.0	± 0.1
Tape width	W	8.0	± 0.3
Distance edge to centre of hole	E	1.75	± 0.1
Distance centre hole to centre compartment	F	3.5	± 0.05
Distance edge to centre compartment	G	0.75	min.

¹⁾ ≤ 0.2 mm over 10 sprocket holes.

Part orientation in tape pocket

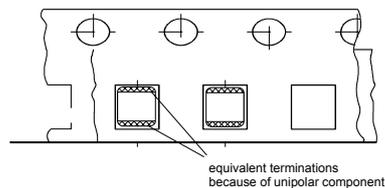

SMD NTC Thermistor
SMD NTC Thermistor with Ni-Barrier Termination
B57621C5103*062

Data sheet

Reel Packing:
Reel material: PS.

Tape material: Blister

Tape break force: min. 10N

Top cover tape peel force: 0.1 - 0.65N at a peel speed of 300 mm/min, angle between top cover tape and the direction of feed during peel off: 165 -180°.

Top cover tape strength: min. 10N

Length of tape:
Leader section: additional top cover tape, length min 400 mm, before component section (including carrier tape with empty cavities, length min. 150 mm or min. 20 pcs. of empty cavities).

Trailer section: length min. 40 mm.

Empty part cavities at leader and trailer section on tape are sealed with top cover tape.

Cavity play:

Each part rests in the cavity so that the angle between the part centreline and the cavity centreline is no more than 20°.

Weight of loaded reel: max. 1500 g

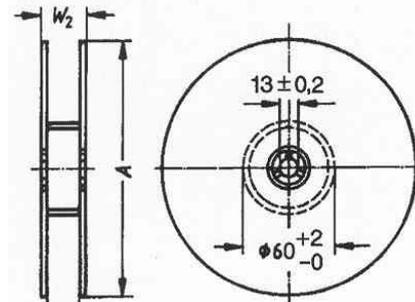
Packing units: 4000pcs.

Package 8 mm tape

Definition	Symbol	Dim. (mm)	Tol. (mm)
Reel diameter	A	180	-3/+0
Reel width (inside)	W_1	8.4	+1.5/-0
Reel width (outside)	W_2	14.4	max.

© EPCOS AG 2005. Reproduction, publication and dissemination of this data sheet, enclosures hereto and the information contained therein without EPCOS' prior express consent is prohibited.

Purchase orders are subject to the General Conditions for the Supply of Products and Services of the Electrical and Electronics Industry recommended by the ZVEI (German Electrical and Electronic Manufacturers' Association), unless otherwise agreed.

ISSUE DATE	02.09.05	ISSUE	b	PUBLISHER	KB S PE	PAGE	7/7
------------	----------	-------	---	-----------	---------	------	-----