

THIS DRAWING IS UNPUBLISHED. RELEASED FOR PUBLICATION
 © COPYRIGHT BY TYCO ELECTRONICS CORPORATION. ALL RIGHTS RESERVED.

| LOC | DIST | REVISIONS | | | |
|-----|------|-----------------------------|-----------|-----|------|
| P | LTR | DESCRIPTION | DATE | DWN | APVD |
| AJ | 16 | REVISED PER EC 0514-0150-05 | 04OCT2005 | REH | JL |

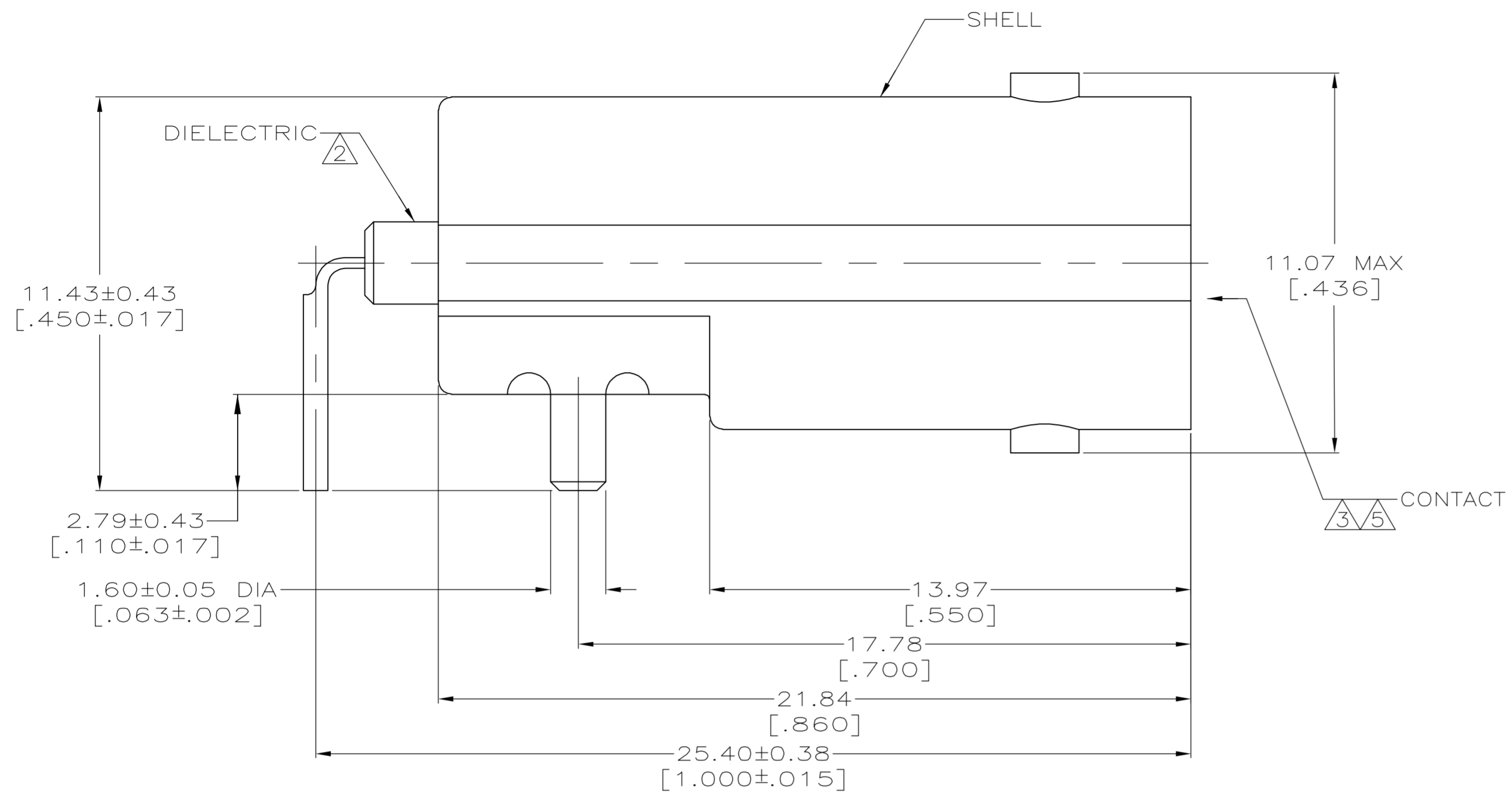

- 1 ZINC PER QQ-Z-363.
- 2 POLYMETHYLPENTENE, GENERAL PURPOSE.
- 3 PHOSPHOR BRONZE PER QQ-B-750.
- 4 NICKEL PLATE PER QQ-N-290, 3.81 μm [.000150] MINIMUM THICK.
- 5 GOLD PLATE PER ASTM B 488, 0.76 μm [.000030] MINIMUM THICK.
- 6 ZAMAK 8

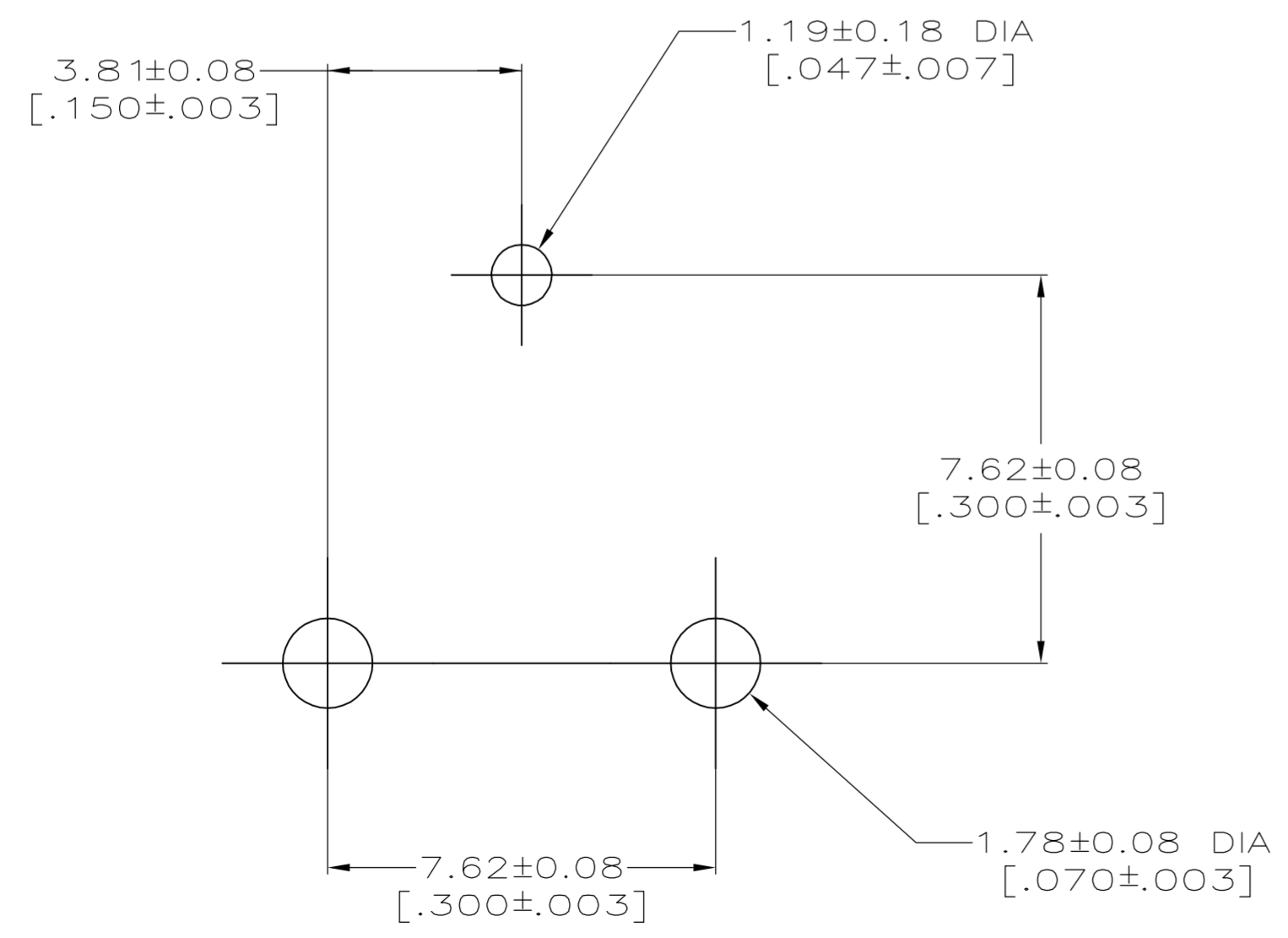

SUGGESTED PCB CONFIGURATION

| | | |
|--------------|----------------|-----------|
| 4 | 6 | 5414373-2 |
| 4 | 1 | 5414373-1 |
| SHELL FINISH | SHELL MATERIAL | PART NO |

| | | | | |
|--|--|----------------------------------|---|--------------|
| THIS DRAWING IS A CONTROLLED DOCUMENT. | | DWN J. ALCORTA - DOCK5 26APR2005 | Tyco Electronics Corporation Harrisburg, PA 17105-3608 | |
| DIMENSIONS: mm [INCHES] | | CHK J. HAVENER 26APR2005 | NAME JACK, RIGHT ANGLE, PCB, 50 OHM, BNC | |
| TOLERANCES UNLESS OTHERWISE SPECIFIED: | | APVD J. LIPPERT 26APR2005 | PRODUCT SPEC 108-12078 | |
| 0 PLC ± - | | APPLICATION SPEC - | | |
| 1 PLC ± - | | SIZE A2 | | |
| 2 PLC ± 0.13 [.005] | | CAGE CODE 00779 | | |
| 3 PLC ± - | | DRAWING NO C=5414373 | | |
| 4 PLC ± - | | RESTRICTED TO - | | |
| ANGLES ± 5° | | SCALE 8:1 | | |
| MATERIAL SEE NOTES 1-3, 6 | | FINISH SEE NOTES 4 - 5 | | SHEET 1 of 1 |
| WEIGHT - | | REV A | | |
| CUSTOMER DRAWING | | | | |

5414373