

**NOTES**

- MATERIAL - 12 GAUGE ALUMINUM COVERS
- PHILLIPS NICKEL PLATED SCREWS
- 0.064" THICK ALUMINUM PANELS
- SELF ADHESIVE RUBBER FEET

\*ALSO AVAILABLE WITHOUT VENTED TOP AND BOTTOM COVERS - #1402H

\*NOTE: FOR DETAILED FRONT AND REAR PANEL DRAWINGS SEE SHEET #2.  
EXTRUSION DRAWING SEE SHEET #3

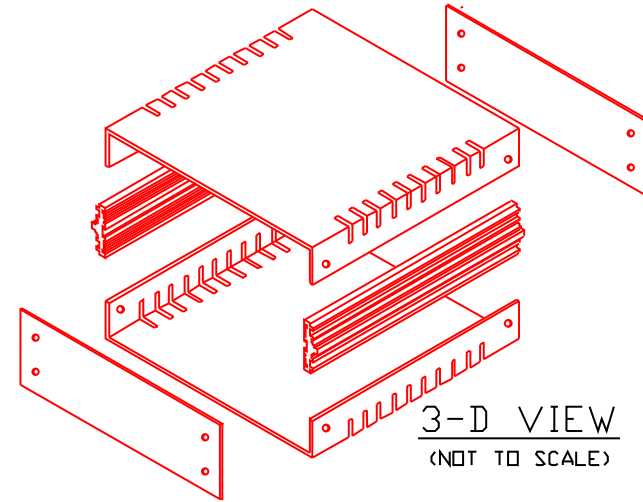

**3-D VIEW**  
(NOT TO SCALE)

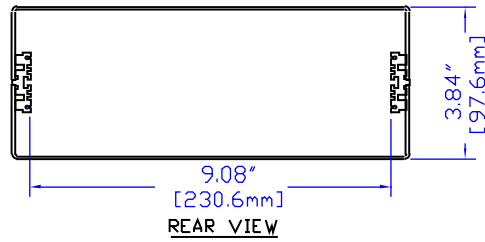

**REAR VIEW**

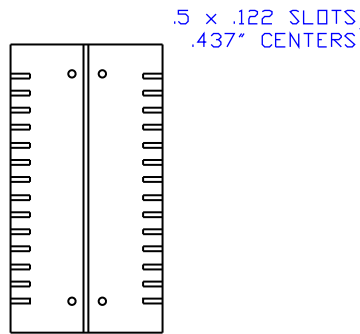

**LEFT SIDE VIEW**

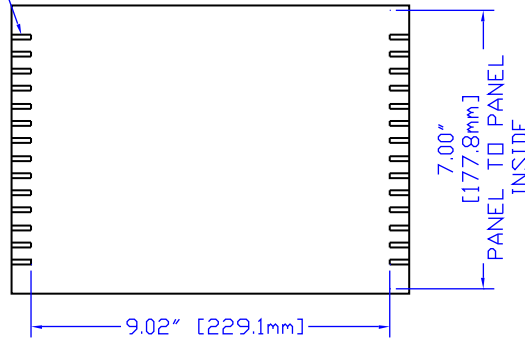

**TOP VIEW**

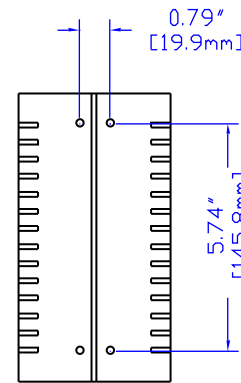

**RIGHT SIDE VIEW**

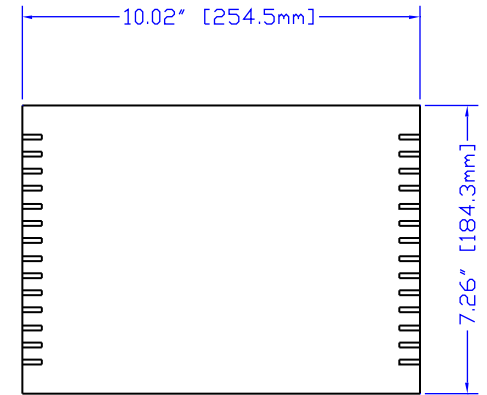

**BOTTOM VIEW**



**FRONT VIEW**

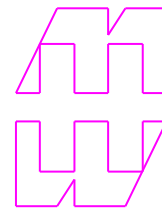

HAMMOND MANUFACTURING

1402HV-Instrument

SHEET 1 OF 3

CANADA - PH (519) 886 7170 - FAX (519) 886 8311  
U.S.A. - PH (716) 631 5700 - FAX (716) 631 1156