

NO. OF CKTS.	DIM. A	DIM. B	SLOT LOC BETWEEN CKTS
2	7.77 .306	3.96±0.05 .156±.002	NONE
3	11.73 .462	7.92±0.08 .312±.003	NONE
4	15.70 .618	11.89±0.08 .468±.003	NONE
5	19.66 .774	15.85±0.10 .624±.004	NONE
6	23.62 .930	19.81±0.10 .780±.004	3 & 4
7	27.58 1.086	23.77±0.10 .936±.004	4 & 5
8	31.55 1.242	27.74±0.13 1.092±.005	4 & 5
9	35.51 1.398	31.70±0.13 1.248±.005	5 & 6
10	39.47 1.554	35.66±0.13 1.404±.005	5 & 6
11	43.43 1.710	39.62±0.15 1.560±.006	6 & 7
12	47.40 1.866	43.59±0.15 1.716±.006	4 & 5 8 & 9

GEN.DOCS.	3-*	F6
ANNNOTATOR	1, 2	F7
SOFTWARE	SHEET	REV

ADD SLOT  
 EC NO: UCP2009-2603  
 DRWN:MKIPPER 2009/05/04  
 CHKD:SSOUSEK 2009/05/04  
 APPR:FSMITH 2009/05/04  
 F7

QUALITY SYMBOLS  
 ▽=0  
 ◻=0

GENERAL TOLERANCES (UNLESS SPECIFIED)

	mm	INCH
4 PLACES	± ---	± ---
3 PLACES	± ---	± .010
2 PLACES	± 0.25	± .015
1 PLACE	± 0.38	± ---

ANGULAR ±1/2°

DRAFT WHERE APPLICABLE MUST REMAIN WITHIN DIMENSIONS

DIMENSION STYLE  
 MM/IN

DRAWN BY  
 JSCHAFFER

DATE  
 11-25-03

CHECKED BY  
 SAMIEC

DATE  
 11-26-03

APPROVED BY  
 MARGULIS

DATE  
 12-1-03

MATERIAL NO.  
 SEE CHART

SIZE  
 A

SCALE  
 2:1

DESIGN UNITS  
 INCH

THIRD ANGLE PROJECTION

TITLE  
 KK .156 HEADER ASSEMBLY  
 FRICTION LOCK RT ANGLE  
 WITH PEGS

MOLEX INCORPORATED

DOCUMENT NO.  
 SD-42492-001

SHEET NO.  
 1 OF 7

THIS DRAWING CONTAINS INFORMATION THAT IS PROPRIETARY TO MOLEX INCORPORATED AND SHOULD NOT BE USED WITHOUT WRITTEN PERMISSION

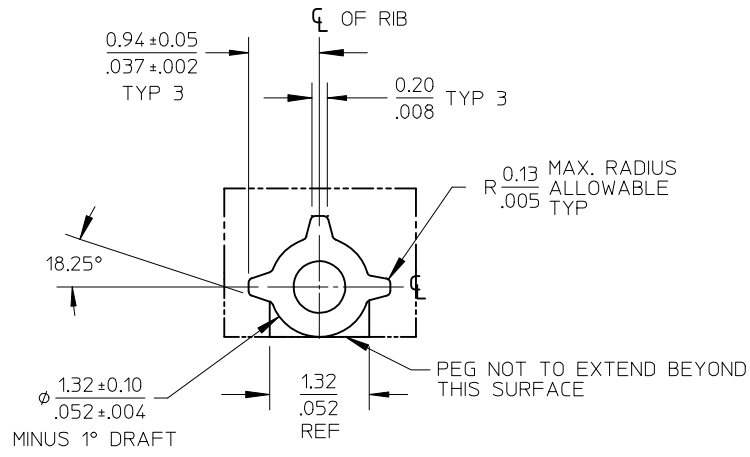

PEG DETAIL  
SCALE 10:1

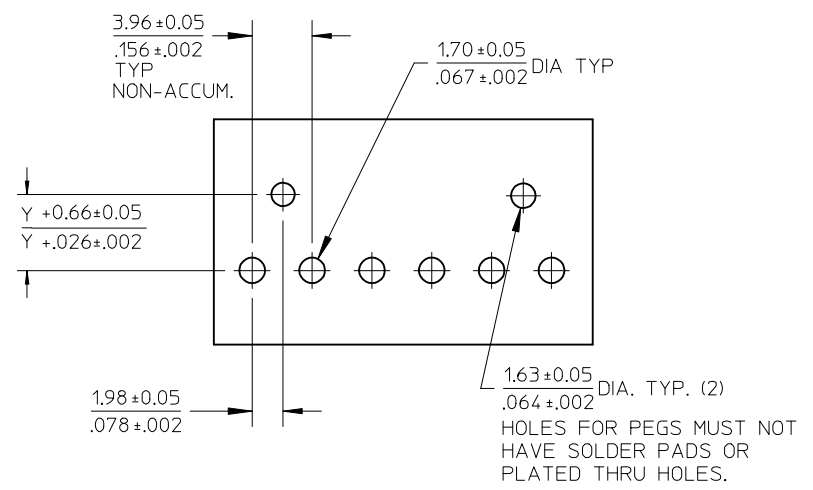

RECOMMENDED PC BOARD HOLE LAYOUT

NOTES:

- MATERIAL: HEADER-POLYESTER, 94V-0, MOLDED NATURAL (WHITE)  
PINS: BRASS
- FINISHES: (102) OVERALL TIN 0.00508/.000200 MIN OVER 0.00254/.000100 MIN. COPPER.  
(154) OVERALL TIN 0.00254/.000100 MIN. OVER 0.00127/.000050 MIN. NICKEL.  
(208) SELECT GOLD 0.00038/.000015 MIN.  
SELECT TIN 0.00254/.000100 MIN.  
OVERALL NICKEL UNDERPLATE 0.00127/.000050 MIN.  
(228) SELECT GOLD 0.00076/.000030 MIN.  
SELECT TIN 0.00254/.000100 MIN.  
OVERALL NICKEL UNDERPLATE 0.00127/.000050 MIN.  
(501) OVERALL GOLD 0.00051/.000020 MIN.  
OVERALL NICKEL UNDERPLATE 0.00076/.000030 MIN.
- PRODUCT SPECIFICATION: SEE PS-08-50.
- PACKAGING INFO: SEE TABLES.
- SOLDERABILITY: PER SMES-152.
- PIN PUSH OUT FORCE: PRIOR TO SOLDERING, A 3 LB MINIMUM FORCE (IN EITHER DIRECTION) SHALL BE REQUIRED TO PUSH THE PIN OUT OF THE HEADER.
- PARTS ARE STACKABLE END TO END ON 3.96/.156 CENTERS.
- FOR PART WITHOUT PEGS SEE 41792.
- THIS PART CONFORMS TO CLASS B REQUIREMENTS OF COSMETIC SPECIFICATION PS-45499-002.
- SLOTS ON BACKWALL ARE BETWEEN CIRCUITS. SEE CHART FOR LOCATION.

SEE SHEET 1 EC NO: UCP2009-2603 DRWN:MKIPPER 2009/05/04 CHKD:SSOUSEK 2009/05/04 APPR:FSMITH 2009/05/04	DESCRIPTION F7	QUALITY SYMBOLS ▽=0 ▽=0	GENERAL TOLERANCES (UNLESS SPECIFIED)		DIMENSION STYLE		SCALE	DESIGN UNITS	THIRD ANGLE PROJECTION		
				mm	INCH	MM/IN	1:1	INCH			
			4 PLACES	± ---	± ---	DRAWN BY	DATE	TITLE			
			3 PLACES	± ---	± .010	JSCHAFFER	11-25-03				
2 PLACES	± 0.25	± .015	CHECKED BY	DATE	KK .156 HEADER ASSEMBLY FRICTION LOCK RT ANGLE WITH PEGS		MOLEX INCORPORATED				
1 PLACE	± 0.38	± ---	SAMIEC	11-26-03							
ANGULAR ± 1/2°			APPROVED BY	DATE	MATERIAL NO.		DOCUMENT NO.		SHEET NO.		
DRAFT WHERE APPLICABLE MUST REMAIN WITHIN DIMENSIONS			MARGULIS	12-1-03							SEE CHART
SIZE A THIS DRAWING CONTAINS INFORMATION THAT IS PROPRIETARY TO MOLEX INCORPORATED AND SHOULD NOT BE USED WITHOUT WRITTEN PERMISSION											

OPTIONS	Group	A-42492-0002/0018	Group	A-42492-0319/0335	Group	A-42492-0336/0352	Group	
	Header No:	41790-0036/0052	Header No:	41790-0036/0052	Header No:	41790-0036/0052	Header No:	
	Pin No:	2161-37(102)	Pin No:	43294-0569	Pin No:	43294-0570	Pin No:	
	Plating:	102 – TIN	Plating:	208 – 15 GOLD	Plating:	228 – 30 GOLD	Plating:	
	Pin Length L	27.94/1.100	Pin Length L	27.94/1.100	Pin Length L	27.94/1.100	Pin Length L	
	Mating M	11.43 / .450	Mating M	11.43/ .450	Mating M	11.43/ .450	Mating M	
	Gold Loc G	N/A	Gold Loc G	6.86/ .270	Gold Loc G	6.86/ .270	Gold Loc G	
	Dim. Y	5.41/ .213	Dim. Y	5.41/ .213	Dim. Y	5.41/ .213	Dim. Y	
	PC Tail P	3.96 / .156	PC Tail P	3.96/ .156	PC Tail P	3.96/ .156	PC Tail P	
	Tin Loc T	OVERALL	Tin Loc T	5.08 / .200	Tin Loc T	5.08 / .200	Tin Loc T	
Voided Ckts	NONE	Voided Ckts	NONE	Voided Ckts	NONE	Voided Ckts		
Pack Per	PK-42492-002	Pack Per	PK-42492-002	Pack Per	PK-42492-002	Pack Per		
Ckts	Material No	Engineer Number	Material No	Engineer Number	Material No	Engineer Number	Material No	Engineer Number
2	26-64-5020	A-42492-0002	42492-0319	A-42492-0319	42492-0336	A-42492-0336		
3	26-64-5030	A-42492-0003	42492-0320	A-42492-0320	42492-0337	A-42492-0337		
4	26-64-5040	A-42492-0004	42492-0321	A-42492-0321	42492-0338	A-42492-0338		
5	26-64-5050	A-42492-0005	42492-0322	A-42492-0322	42492-0339	A-42492-0339		
6	26-64-5060	A-42492-0006	42492-0323	A-42492-0323	42492-0340	A-42492-0340		
7	26-64-5070	A-42492-0007	42492-0324	A-42492-0324	42492-0341	A-42492-0341		
8	26-64-5080	A-42492-0008	42492-0325	A-42492-0325	42492-0342	A-42492-0342		
9	26-64-5090	A-42492-0009	42492-0326	A-42492-0326	42492-0343	A-42492-0343		
10	26-64-5100	A-42492-0010	42492-0327	A-42492-0327	42492-0344	A-42492-0344		
11	26-64-5110	A-42492-0011	42492-0328	A-42492-0328	42492-0345	A-42492-0345		
12	26-64-5120	A-42492-0012	42492-0329	A-42492-0329	42492-0346	A-42492-0346		
13								
14								
15								
16								
17								
18								

REV: <b>F6</b>	ECR/ECN INFORMATION: EC No.: <b>UCP2009-2116</b> DATE: <b>2/26/2009</b>	TITLE: <b>KK 156 HEADER ASSEMBLY FRICTION LOCK RT ANGLE WITH PEGS</b>	SHEET No. <b>- 3 -</b>
DOCUMENT NUMBER: <b>SD- 42492-001</b>	CREATED / REVISED BY: <b>MKIPPER</b>	CHECKED BY: <b>SSOUSEK</b>	APPROVED BY: <b>FSMITH</b>

OPTIONS	Group	A-42492-0036/0050	Group	A-42492-0244/0256	Group	A-42492-0258/0273	Group	A-42492-0274/0288
	Header No:	41790-0038/0052	Header No:	41790-0040/0052	Header No:	41790-0037/0052	Header No:	41790-0038/0052
	Pin No:	2161-37(102)	Pin No:	2161-37(102)	Pin No:	2161-37(102)	Pin No:	2161-37(501)
	Plating:	102 – TIN	Plating:	102 – TIN	Plating:	102 – TIN	Plating:	501 - GOLD
	Pin Length L	27.94/1.100	Pin Length L	27.94/1.100	Pin Length L	27.94/1.100	Pin Length L	27.94/1.100
	Mating M	11.43 / .450	Mating M	11.43/. 450	Mating M	11.43/. 450	Mating M	11.43/. 450
	Gold Loc G	N/A	Gold Loc G	N/A	Gold Loc G	N/A	Gold Loc G	OVERALL
	Dim. Y	5.41/ .213	Dim. Y	5.41/ .213	Dim. Y	5.41/ .213	Dim. Y	5.41/ .213
	PC Tail P	3.96 / .156	PC Tail P	3.96/ . 156	PC Tail P	3.96/. 156	PC Tail P	3.96/. 156
	Tin Loc T	OVERALL	Tin Loc T	OVERALL	Tin Loc T	OVERALL	Tin Loc T	N/A
Voided Ckts	4	Voided Ckts	6	Voided CKts	2	Voided Ckts	4	
Pack Per	PK-42492-002	Pack Per	PK-42492-002	Pack Per	PK-42492-002	Pack Per	PK-42492-002	
Ckts	Material No	Engineer Number	Material No	Engineer Number	Material No	Engineer Number	Material No	Engineer Number
2								
3								
4	26-64-5042	A-42492-0036						
5	26-64-5052	A-42492-0037			26-66-0031	A-42492-0258	424-92-0274	A-42492-0274
6	26-64-5062	A-42492-0038	26-64-5061	A-42492-0244	26-66-0041	A-42492-0259	424-92-0275	A-42492-0275
7	26-64-5072	A-42492-0039	26-64-5071	A-42492-0245	26-66-0051	A-42492-0260	424-92-0276	A-42492-0276
8	26-64-5082	A-42492-0040	26-64-5081	A-42492-0246	26-66-0061	A-42492-0261	424-92-0277	A-42492-0277
9	26-64-5092	A-42492-0041	26-64-5091	A-42492-0247	26-66-0071	A-42492-0262	424-92-0278	A-42492-0278
10	26-64-5102	A-42492-0042	26-64-5101	A-42492-0248	26-66-0081	A-42492-0263	424-92-0279	A-42492-0279
11	26-64-5112	A-42492-0043	26-64-5111	A-42492-0249	26-66-0091	A-42492-0264	424-92-0280	A-42492-0280
12	26-64-5122	A-42492-0044	26-64-5121	A-42492-0250	26-66-0101	A-42492-0265	424-92-0281	A-42492-0281
13					26-66-0111	A-42492-0266	424-92-0282	A-42492-0282
14					26-66-0121	A-42492-0267		
15								
16								
17								
18								

REV: <b>F6</b>	ECR/ECN INFORMATION: EC No.: <b>UCP2009-2116</b> DATE: <b>2/26/2009</b>	TITLE: <b>KK 156 HEADER ASSEMBLY FRICTION LOCK RT ANGLE WITH PEGS</b>	SHEET No. <b>- 4 -</b>
DOCUMENT NUMBER: <b>SD- 42492-001</b>	CREATED / REVISED BY: <b>MKIPPER</b>	CHECKED BY: <b>SSOUSEK</b>	APPROVED BY: <b>FSMITH</b>

OPTIONS	Group	A-42492-0289/0302	Group	A-42492-0303/0318	Group	A-42492-0019/0035	Group	A-42492-0400/0416
	Header No:	41790-0039/0052	Header No:	41790-0037/0052	Header No:	41790-0036/0052	Header No:	41790-0036/0052
	Pin No:	2161-37(102)	Pin No:	2161-37(102)	Pin No:	2161-37(501)	Pin No:	2161-19(102)
	Plating:	102 – TIN	Plating:	102 – TIN	Plating:	501 - GOLD	Plating:	102 - TIN
	Pin Length L	27.94/1.100	Pin Length L	27.94/1.100	Pin Length L	27.94/1.100	Pin Length L	26.21/ 1.032
	Mating M	11.43 / .450	Mating M	11.43/ .450	Mating M	11.43/ .450	Mating M	11.43/ .450
	Gold Loc G	N/A	Gold Loc G	6.86/ .270	Gold Loc G	OVERALL	Gold Loc G	N/A
	Dim. Y	5.41/ .213	Dim. Y	5.41/ .213	Dim. Y	5.41/ .213	Dim. Y	5.41/ .213
	PC Tail P	3.96 / .156	PC Tail P	3.96/ .156	PC Tail P	3.96/ .156	PC Tail P	2.23/ .088
	Tin Loc T	OVERALL	Tin Loc T	OVERALL	Tin Loc T	N/A	Tin Loc T	OVERALL
Voided Ckts	5	Voided Ckts	3	Voided CKts	NONE	Voided Ckts	NONE	
Pack Per	PK-42492-002	Pack Per	PK-42492-002	Pack Per	PK-42492-002	Pack Per	PK-42492-002	
Ckts	Material No	Engineer Number	Material No	Engineer Number	Material No	Engineer Number	Material No	Engineer Number
2					26-65-5020	A-42492-0019	42492-0400	A-42492-0400
3			424-92-0303	A-42492-0303	26-65-5030	A-42492-0020	42492-0401	A-42492-0401
4			424-92-0304	A-42492-0304	26-65-5040	A-42492-0021	42492-0402	A-42492-0402
5	424-92-0289	A-42492-0289	424-92-0305	A-42492-0305	26-65-5050	A-42492-0022	42492-0403	A-42492-0403
6	424-92-0290	A-42492-0290	424-92-0306	A-42492-0306	26-65-5060	A-42492-0023	42492-0404	A-42492-0404
7	424-92-0291	A-42492-0291	424-92-0307	A-42492-0307	26-65-5070	A-42492-0024	42492-0405	A-42492-0405
8	424-92-0292	A-42492-0292	424-92-0308	A-42492-0308	26-65-5080	A-42492-0025	42492-0406	A-42492-0406
9	424-92-0293	A-42492-0293	424-92-0309	A-42492-0309	26-65-5090	A-42492-0026	42492-0407	A-42492-0407
10	424-92-0294	A-42492-0294	424-92-0310	A-42492-0310	26-65-5100	A-42492-0027	42492-0408	A-42492-0408
11	424-92-0295	A-42492-0295	424-92-0311	A-42492-0311	26-65-5110	A-42492-0028	42492-0409	A-42492-0409
12	424-92-0296	A-42492-0296	424-92-0312	A-42492-0312	26-65-5120	A-42492-0029	42492-0410	A-42492-0410
13								
14								
15								
16								
17								
18								

REV:	<u>ECR/ECN INFORMATION:</u>	<u>TITLE:</u>	<u>SHEET No.</u>
<b>F6</b>	EC No.: <b>UCP2009-2116</b>	<b>KK 156 HEADER ASSEMBLY FRICTION LOCK RT ANGLE WITH PEGS</b>	<b>- 5 -</b>
	DATE: <b>2/26/2009</b>		
<u>DOCUMENT NUMBER:</u>	<u>CREATED / REVISED BY:</u>	<u>CHECKED BY:</u>	<u>APPROVED BY:</u>
<b>SD- 42492-001</b>	<b>MKIPPER</b>	<b>SSOUSEK</b>	<b>FSMITH</b>

OPTIONS	Group	A-42492-0417/0431	Group	A-42492-0432/0443	Group	A-42492-0444/0456	Group	A-42492-0461/0473
	Header No:	41790-0036/0052	Header No:	41790-0041/0052	Header No:	41790-0040/0052	Header No:	41790-0040/0052
	Pin No:	2161-37(102)	Pin No:	2161-37(102)	Pin No:	2161-37(102)	Pin No:	2161-37(102)
	Plating:	102 – TIN	Plating:	102 – TIN	Plating:	102 – TIN	Plating:	102 – TIN
	Pin Length L	27.94/1.100	Pin Length L	27.94/1.100	Pin Length L	27.94/1.100	Pin Length L	27.94/1.100
	Mating M	11.43 / .450	Mating M	11.43/. 450	Mating M	11.43/. 450	Mating M	11.43/. 450
	Gold Loc G	N/A	Gold Loc G	N/A	Gold Loc G	N/A	Gold Loc G	N/A
	Dim. Y	5.41/ .213	Dim. Y	5.41/ .213	Dim. Y	5.41/ .213	Dim. Y	5.41/ .213
	PC Tail P	3.96 / .156	PC Tail P	3.96/ . 156	PC Tail P	3.96/. 156	PC Tail P	3.96/. 156
	Tin Loc T	OVERALL	Tin Loc T	OVERALL	Tin Loc T	OVERALL	Tin Loc T	OVERALL
Voided Ckts	2, 4	Voided Ckts	1,4,5,6,7	Voided CKts	3, 6	Voided Ckts	4, 6	
Pack Per	PK-42492-002	Pack Per	PK-42492-002	Pack Per	PK-42492-002	Pack Per	PK-42492-002	
Ckts	Material No	Engineer Number	Material No	Engineer Number	Material No	Engineer Number	Material No	Engineer Number
2								
3								
4	42492-0417	A-42492-0417						
5	42492-0418	A-42492-0418						
6	42492-0419	A-42492-0419			42492-0444	A-42492-0444		
7	42492-0420	A-42492-0420	42492-0432	A-42492-0432	42492-0445	A-42492-0445	42492-0462	A-42492-0462
8	42492-0421	A-42492-0421	42492-0433	A-42492-0433	42492-0446	A-42492-0446		
9	42492-0422	A-42492-0422	42492-0434	A-42492-0434	42492-0447	A-42492-0447		
10	42492-0423	A-42492-0423	42492-0435	A-42492-0435	42492-0448	A-42492-0448		
11	42492-0424	A-42492-0424	42492-0436	A-42492-0436	42492-0449	A-42492-0449		
12	42492-0425	A-42492-0425	42492-0437	A-42492-0437	42492-0450	A-42492-0450		
13								
14								
15								
16								
17								
18								

REV:	ECR/ECN INFORMATION:	TITLE:	SHEET No.
<b>F6</b>	EC No.: <b>UCP2009-2116</b>	<b>KK 156 HEADER ASSEMBLY FRICTION LOCK RT ANGLE WITH PEGS</b>	<b>- 6 -</b>
	DATE: <b>2/26/2009</b>		
DOCUMENT NUMBER:	CREATED / REVISED BY:	CHECKED BY:	APPROVED BY:
<b>SD- 42492-001</b>	<b>MKIPPER</b>	<b>SSOUSEK</b>	<b>FSMITH</b>

OPTIONS	Group	A-42492-0474
	Header No:	41790-0040/0052
	Pin No:	2161-37(154)
	Plating:	154 – TIN
	Pin Length L	27.94/1.100
	Mating M	11.43 / .450
	Gold Loc G	N/A
	Dim. Y	5.41/ .213
	PC Tail P	3.96 / .156
	Tin Loc T	OVERALL
	Voided Ckts	2, 5, 6
Pack Per	PK-42492-002	
Ckts	Material No	Engineer Number
2		
3		
4		
5		
6		
7	42492-0474	A-42492-0474
8		
9		
10		
11		
12		
13		
14		
15		
16		
17		
18		

REV: <b>F6</b>	ECR/ECN INFORMATION: EC No.: <b>UCP2009-2116</b> DATE: <b>2/26/2009</b>	TITLE: <b>KK 156 HEADER ASSEMBLY FRICTION LOCK RT ANGLE WITH PEGS</b>	SHEET No. <b>- 7 -</b>
DOCUMENT NUMBER: <b>SD- 42492-001</b>	CREATED / REVISED BY: <b>MKIPPER</b>	CHECKED BY: <b>SSOUSEK</b>	APPROVED BY: <b>FSMITH</b>