

Molex connector ; 6
 Housing 5264-02
 Terminal 5263 PBT

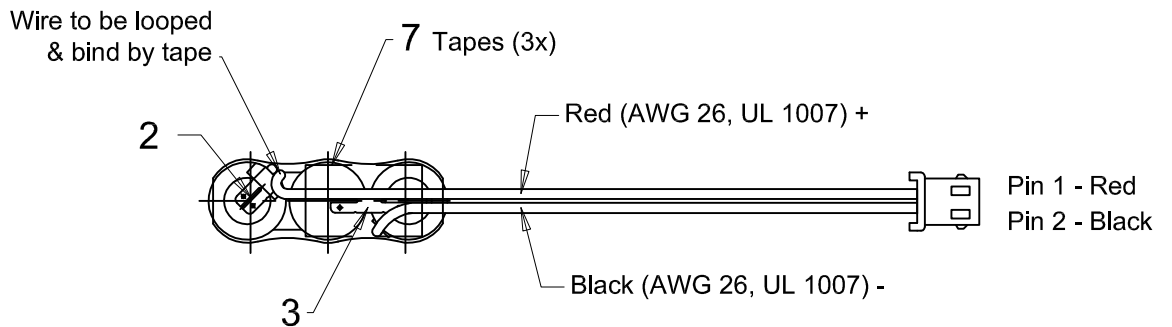
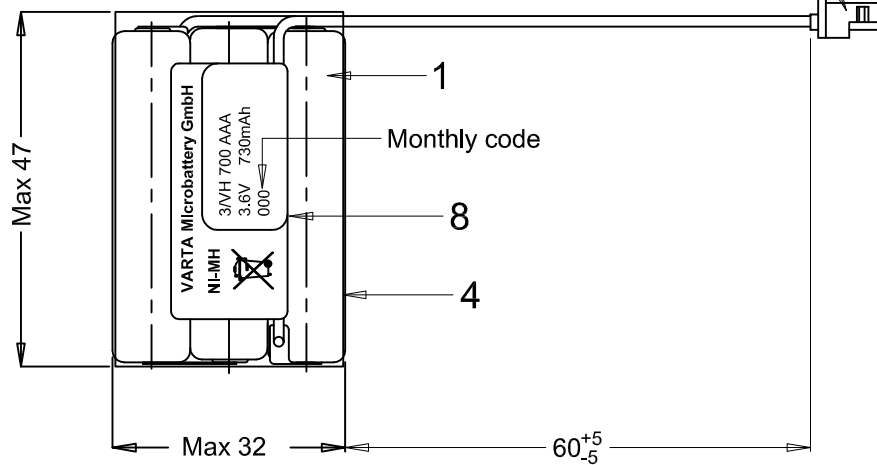
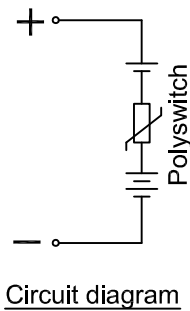

Note : 1) Battery is totally insulated
 2) Battery with non-Standard polarity

Approx.wt : 40 g

0	T041/07	Refer to 3/VH 700 AAA # 692815, rev: 400, but use new source cell, battery height change from Max 46 to Max 47	2007-08-03	Ben
No	AO No	Revisions	1	Date Name

Projection:		Material: Refer to part list no: 698301		Description: 3/VH700 L S WC with sleeve & wire connector	
Dimensions in mm		Prepared & Checked	Verified & Approved	Dwg. No:	698301
Tolerance: As specified		2007-08-03	Ben	VKB Order No:	55171 403 014
Scale: 1 : 1					400