

MCEEC0251B2-0000-A99



DC Brushless Fan

Specifications:

Mechanical Characteristic



Motor design	2 phases, 4 - poles brushless DC motor
Bearing system	Precision ball bearing system
Dimensions	See page 2
Materials of frame	Thermoplastic PBT
Materials of fan blade	Thermoplastic PBT
Direction of rotation	Counter-clockwise viewed from front of fan blade
Mounting holes	Diameter 4.3 mm in 8 holes
Weight	157 g

Electric Characteristic

Rated voltage	12 V dc
Rated current	451 mA
Rated power consumption	5.4 watts
Operating voltage range	6 to 13.8 V dc
Starting voltage	6 V dc (25°C power on / off)
Operating temperature range	-10 to +70°C
Storage temperature range	-40 to +70°C

Performance Characteristic

Rated speed	3,100 RPM \pm 10% at rated voltage
Air flow	108.2 CFM
Static pressure	0.28 Inch-H ₂ O
Acoustic noise	44.5 dB(A)
Air flow V.S. pressure	See Page 2
Insulation class	UL Class A
Insulation resistance plastic housing	10 M Ω at 500 V dc between internal stator and lead wire (+)
Dielectric strength	Applied 500 V ac for one minute or 600 V ac for 2 Seconds between housing and lead wire (+)
Life expectancy	35,000 Hours at 40°C, 65% humidity, 90% CL
Protection	Automatic Restart Note: In a situation where the fan is locked by an external force while the electricity is on, an increase in coil temperature will be prevented by temporarily turning off the electrical power to the motor. The fan will automatically restart when the locked rotor condition is released
	Polarity Protection

MCEEC0251B2-0000-A99



DC Brushless Fan

Performance Curves

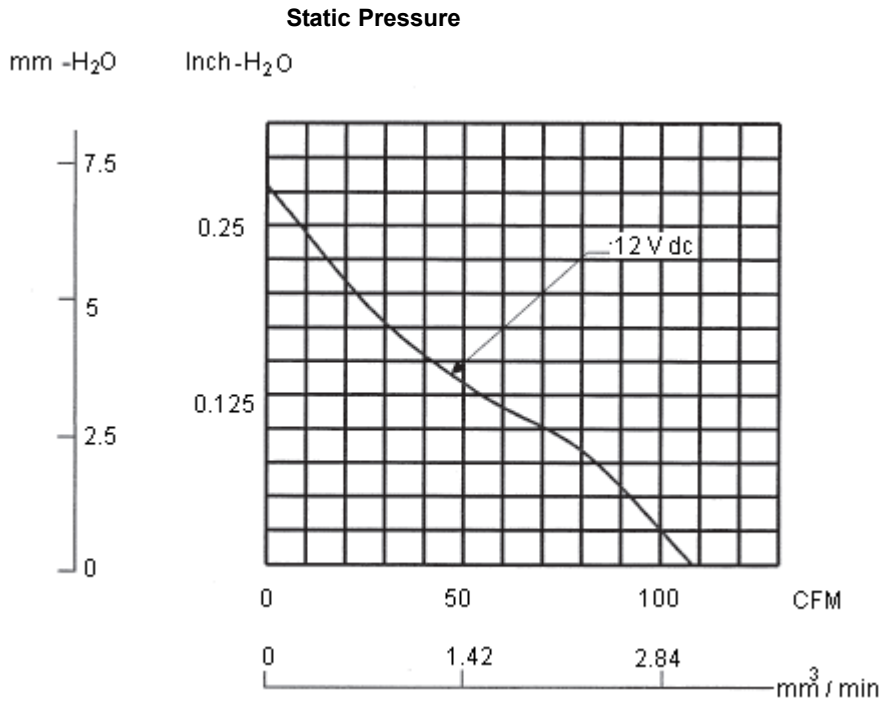

Dimensions

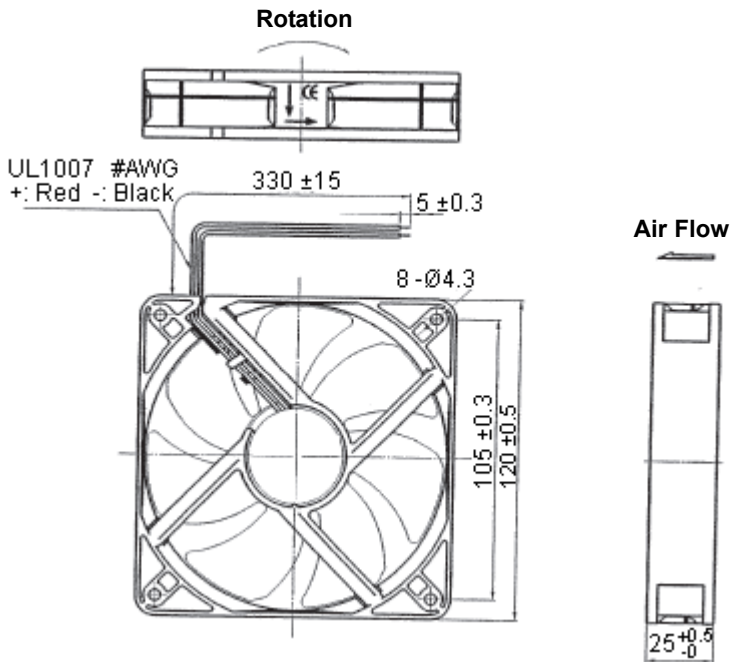

Dimensions : Millimetres



DC Brushless Fan

Other Specified Testing

The following is a general description of certain tests that are performed on representative fans. Nothing in this document is intended to suggest that these tests are performed on every model of fan. Moreover, the descriptions that follow each test are meant only to provide a general explanation of each test. If you would like a more detailed explanation as to any test identified in this Section, can provide such an explanation upon request

Drop Proof Test

Fans are packaged in a standard size shipping box and are dropped to the ground from certain heights and angles depending on the weight of the particular box

Humidity Proof Test

The fan is operated for 96 continuous hours in an environment with humidity of 90% to 95% RH at $60^{\circ}\text{C} \pm 2^{\circ}\text{C}$

Vibration Proof Test

Vibration with an amplitude 2 mm and a frequency of 5-55-5hz is applied in all 3 directions (X, Y, Z) in cycles of 1 hour each, for a total vibration time of 3 hrs

Thermal Cycling Test

The fan is operated in a testing chamber for 50 cycles. In each cycle, the temperature is gradually increased from -10°C to 70°C for 90 minutes, and subsequently operated at 70°C for 120 minutes. The temperature is then gradually decreased from 70°C to -10°C for 90 minutes, and subsequently operated at -10°C for 120 mins

Shock Proof Test

100G of force is applied in the 3 directions (X,Y, and Z) for 2 milliseconds each

Life Expectancy

The "Life Expectancy" of fans is determined in reliability test laboratory by using temperature chambers. The "Life Expectancy" of this fan has not been evaluated for use in combination with any end application. Therefore, the Life Expectancy Test Reports (L10 and MTTF Report) that relate to this fan are only for reference

Characteristic Definition

The following is a general description of certain tests that are performed on representative fans in order to determine the specifications of the fan. Nothing in this document is intended to suggest that these tests are performed on every model of fan. Moreover, the descriptions that follow each test are meant only to provide a general explanation of each test. If you would like a more detailed explanation as to any test identified in this Section, can provide such an explanation upon request

Acoustical Noise

Measured in a semi-anechoic chamber with background noise level below 15dB(A)

The fan is running in free air under shaft horizontal condition with the microphone at distance of one meter from die fan intake

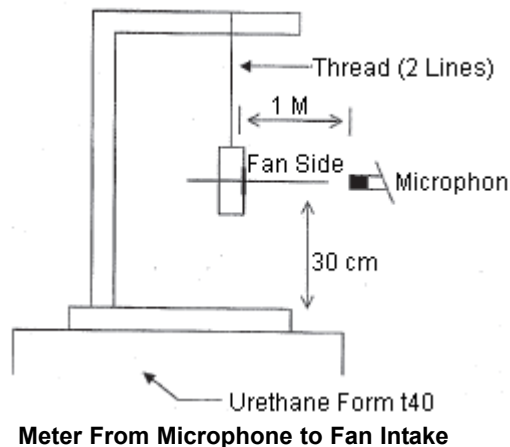

MCEEC0251B2-0000-A99



DC Brushless Fan

Input Power

Measured after continuous 10 minutes operation at rated voltage in clean air (static pressure = 0) and at ambient temperature of 25°C under shaft horizontal condition

Rated Current

Measured after continuous 10 minutes operation at rated voltage in clean air (static pressure = 0) and at ambient temperature of 25°C under shaft horizontal condition

Rated Speed

Measured after continuous 10 minutes operation at rated voltage in clean air (static pressure = 0) and at ambient temperature of 25°C under shaft horizontal condition

Starting Voltage

Measured the voltage which enables to start the fan in the clean air (static pressure = 0) by switching on at the voltage under shaft horizontal condition. It is not at continuously increasing voltage adjustment

Locked Rotor Current

Measured immediately after the fan blade is locked

Air Flow and Static Pressure

The performance specification of air flow and static pressure shown in this specification for approval is measured using the exhaust method. A double chamber is used in accordance with AMCA 210 standard or DIN 24163 specification. The values are recorded when the fan speed has stabilized at rated voltage

Insulation Resistance

Plastic Housing:

- (1) Measured between internal stator and lead wire (+)
- (2) Measured between housing and lead wire (+)

Aluminium Housing:

Measured between internal stator and lead wire (+)

Dielectric Strength

Measure between housing and lead wire (+)

Warranty

This fan is warranted against all defects which are proved to be fault in our workmanship and material for one year from the date of our delivery. The sole responsibility under the warranty shall be limited to the repair of the fan or the replacement thereof, at sole discretion. Will not be responsible for the failures of its fans due to improper handling, misuse or the failure to follow specifications or instructions for use. In the event of warranty claim, the customer shall immediately notify for verification. Will not be responsible for any consequential damage to the customer's equipment as a result of any fans proven to be defective

Part Number Table

Description	Part Number
Fan, 119 mm, 12 V dc	MCEEC0251B2-0000-A99

Important Notice : This data sheet and its contents (the "Information") belong to the members of the Premier Farnell group of companies (the "Group") or are licensed to it. No licence is granted for the use of it other than for information purposes in connection with the products to which it relates. No licence of any intellectual property rights is granted. The Information is subject to change without notice and replaces all data sheets previously supplied. The Information supplied is believed to be accurate but the Group assumes no responsibility for its accuracy or completeness, any error in or omission from it or for any use made of it. Users of this data sheet should check for themselves the Information and the suitability of the products for their purpose and not make any assumptions based on information included or omitted. Liability for loss or damage resulting from any reliance on the Information or use of it (including liability resulting from negligence or where the Group was aware of the possibility of such loss or damage arising) is excluded. This will not operate to limit or restrict the Group's liability for death or personal injury resulting from its negligence. Multicomp is the registered trademark of the Group. © Premier Farnell plc 2011.