

San Ace 100W

Splash Proof Centrifugal Fan

Splash Proof Centrifugal Fan 100mm

Features

Splash proof and dust resistant

- Protection class IP54* water and dust resistant performance.
- Maintains safe operation even in harsh environments.

Large air flow and high static pressure

- Maximum air flow : 2.03 m³/min
- Maximum static pressure : 708 Pa

Energy-saving and Low noise

- Power consumption: 17.28W
- Sound Pressure Level: 65dB(A)



※ "IP54" is a protection specification for protection against water sprays and dust.

It is based on IEC (International Electrotechnical Commission) and JIS (Japanese Industrial Standards) and specified as follows.

Ingress of dust is not entirely prevented, but it must not enter in sufficient quantity to interfere with the satisfactory operation of the equipment; complete protection against contact. Water splashing against the enclosure from any direction shall have no harmful effect.

φ 100mm × 25mm

Specifications

When our inlet nozzle [Option (Model NO. : 109-1080)] is mounted.

Model No.	Rated Voltage [V]	Operating Voltage Range [V]	PWM Duty Cycle* [%]	Rated Current [A]	Rated Input [W]	Rated Speed [min ⁻¹]	Air Flow [m ³ /min] [CFM]		Static Pressure [Pa] [inchH ₂ O]		SPL [dB(A)]	Operating Temperature [°C]	Life Expectancy [h]
9W1TM48P4G01	48	36 to 60	^{Note 1)} 100	0.36	17.28	7,400	2.03	71.7	708	2.84	65	-10 to +70	40,000
9W1TM48P4H01			100	0.22	10.56	6,400	1.77	62.5	560	2.25	60		
			0	0.04	1.92	2,000	0.51	18.0	48	0.19	34		

Note 1 : Fan does not rotate when PWM duty cycle is 0%.

Max input is 9W1TM48P4G01 : 22W, 9W1TM48P4H01 : 14W at rated voltage.

* PWM Frequency : 25kHz

Common Specifications

- Material Motor case : Aluminum (Black Painting), Impeller : Plastics (Flammability: UL94V-0)
- Life Expectancy Varies for each model
(L10: Survival rate: 90% at 60°C, rated voltage, and continuously run in a free air state)
- Motor Protection System Current blocking function and reverse polarity protection
- Dielectric Strength 50/60 Hz, 500VAC, 1 minute (between lead conductor and motor case)
- Sound Pressure Level (SPL) Expressed as the value at 1m from air inlet side
- Storage Temperature -30°C to +70°C (Non-Condensing)
- Lead Wire ⊕red ⊖black Sensor : yellow Control : brown
- Mass Approx. 160g

100mm

SanAce 100W

Air Flow - Static Pressure Characteristics

- PWM Duty Cycle

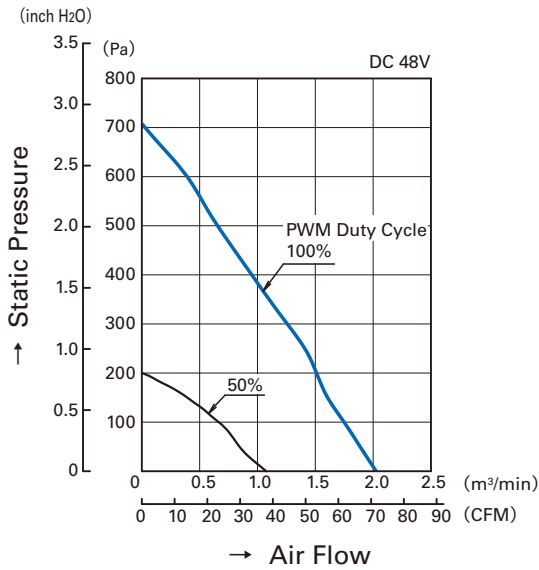

9W1TM48P4G01

- Operating Voltage Range

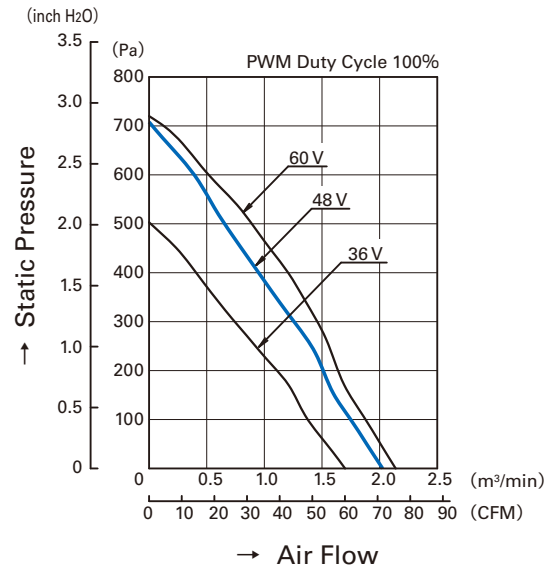

9W1TM48P4G01

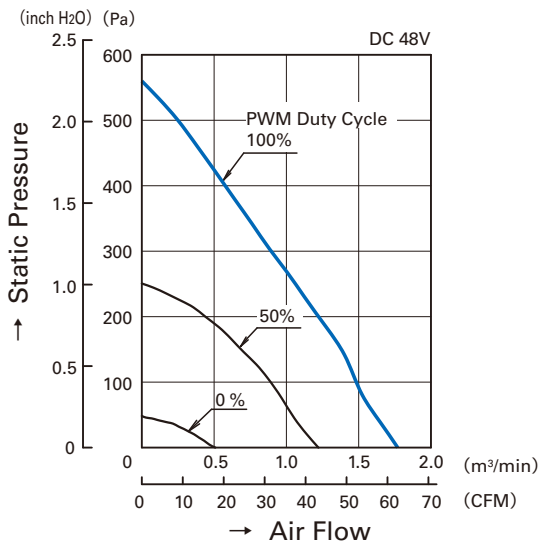

9W1TM48P4H01

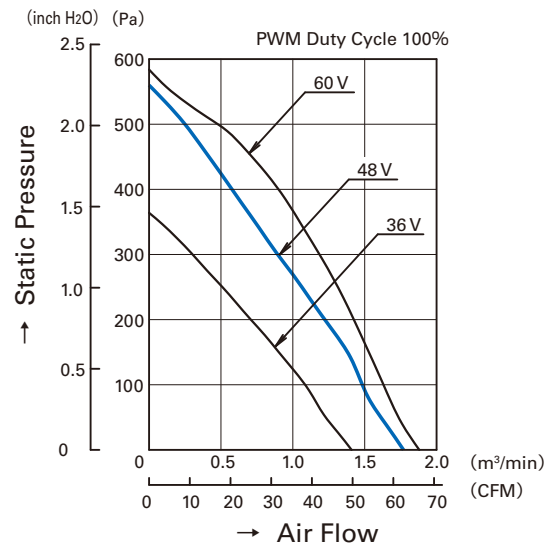

9W1TM48P4H01

PWM Duty - Speed Characteristics Example

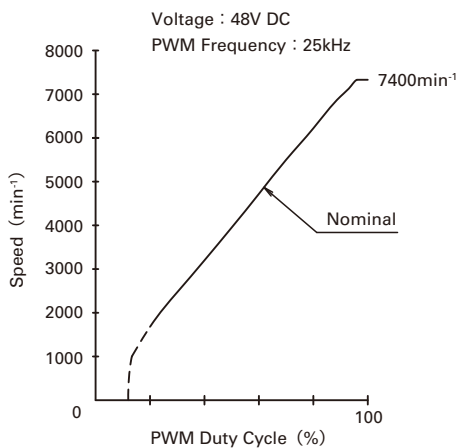

9W1TM48P4G01

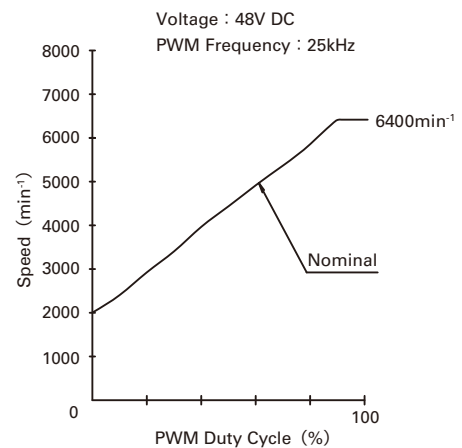

9W1TM48P4H01

PWM Input Signal Example

Input Signal Wave Form

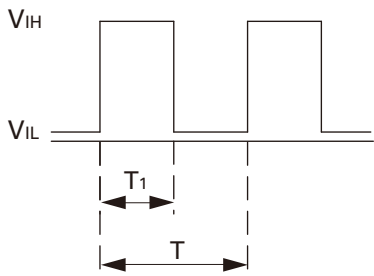

$V_{IH}=4.75V$ to $5.25V$

$V_{IL}=0V$ to $0.4V$

PWM Duty Cycle (%) = $\frac{T_1}{T} \times 100$

PWM Frequency 25 (kHz) = $\frac{1}{T}$

Source Current : 2mA Max. at control voltage 0V

Sink Current : 1mA Max. at control voltage 5.25V

Control Terminal Voltage : 10V Max. (Open Circuit)

When the control lead wire is no connecting, the speed is the same speed as at 100% of PWM cycle.

This fan speed should be controlled by PWM input signal of either TTL input or open collector, drain input.

Connection Schematic

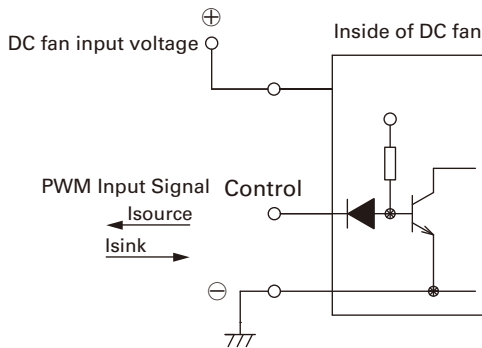

Specifications for Pulse Sensors

Output circuit : Open collector

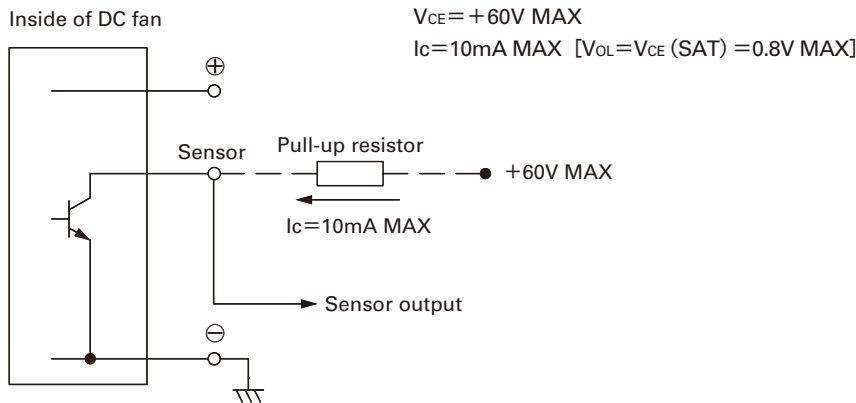

Output waveform (Need pull-up resistor)

In case of steady running

(One revolution)

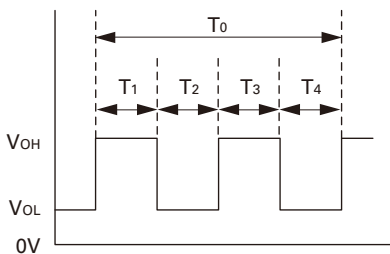

$T_{1\sim 4} \doteq (1/4) T_0$

$T_{1\sim 4} \doteq (1/4) T_0 = 60/4N$ (sec)

$N = \text{Fan speed (min}^{-1}\text{)}$

Dimensions (unit : mm)

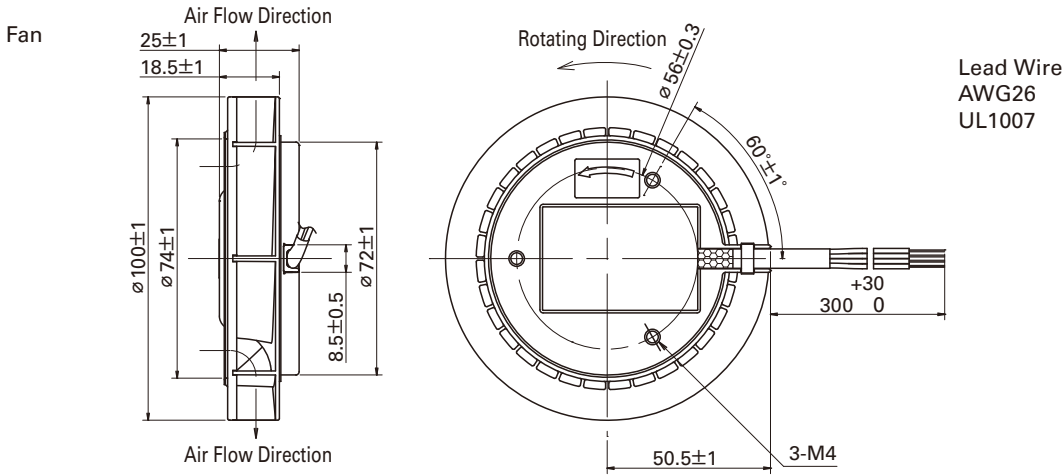

Inlet nozzle
(Model No. : 109-1080)

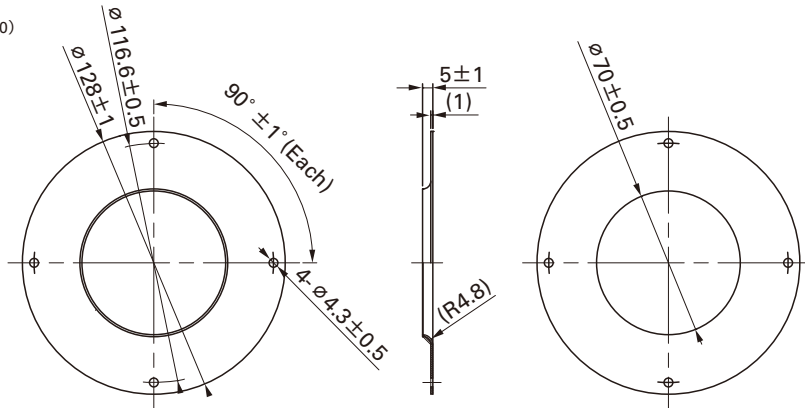

Inlet nozzle : Nozzle mounted in fan inlet side to adjust the flow of introduced air

Reference dimension of mounting holes and vent opening (unit : mm)

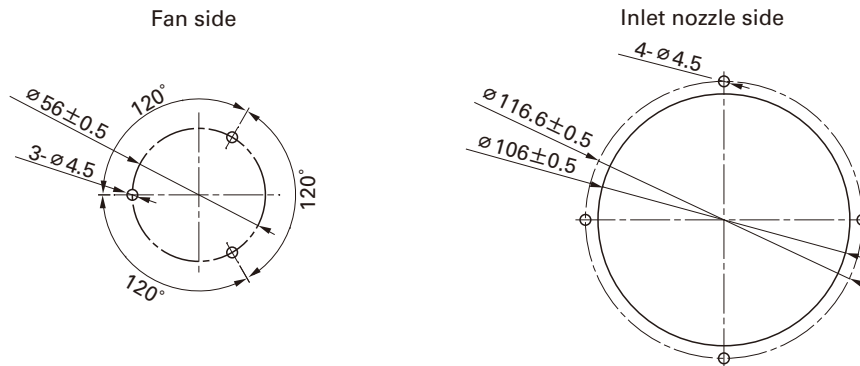

Reference diagram for mounting

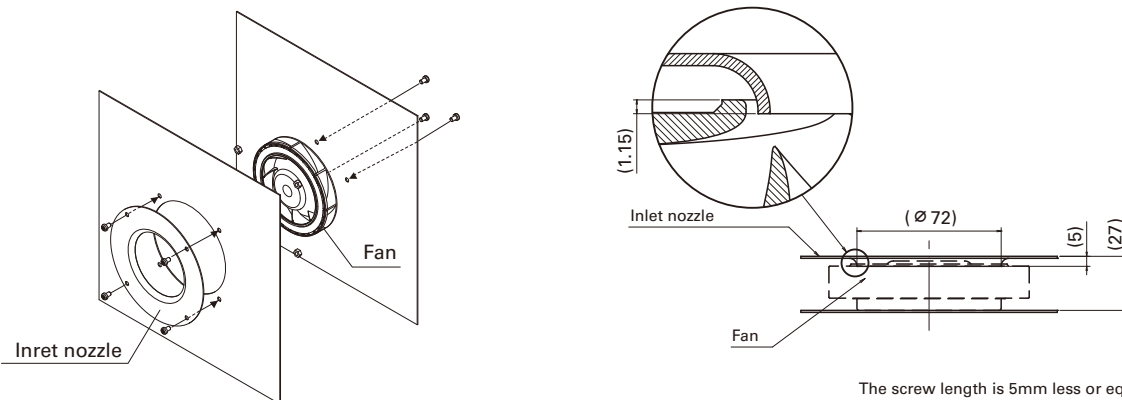

The screw length is 5mm less or equal from fan edge side.

Notice

- The products shown in the catalog are subject to Japanese Export Control Law. Diversion contrary to the law of exporting country is prohibited.
- To protect against electrolytic corrosion that may occur in locations with strong electromagnetic noise, we provide fans that are unaffected by electrolytic corrosion.

SANYO DENKI CO., LTD. 1-15-1, Kita-otsuka, Toshima-ku, Tokyo 170-8451, Japan. PHONE :+ 81 3 3917 5151 Home Page: <http://www.sanyodenki.co.jp>