

Global Connector Technology Ltd. - USB3080: Micro USB Receptacle, Type B, SMT, Horizontal, Bottom Mount (Standard), with Optional Plastic Locating Peg and Inner Shell Stakes

Designed to comply with physical, electrical and environmental requirements of Micro USB Standard (USB2.0).

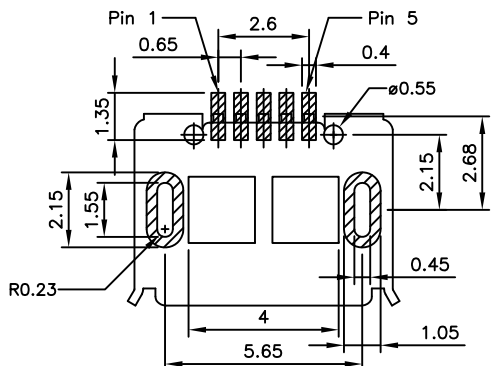

RECOMMENDED P.C.B LAYOUT
 GENERAL TOLERANCE: ±0.05
 AS VIEWED FROM COMPONENT SIDE
 [Hatched Box] Solder Area
 [White Box] Component Outline

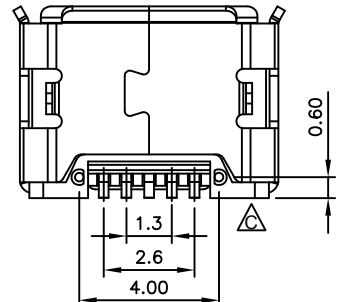
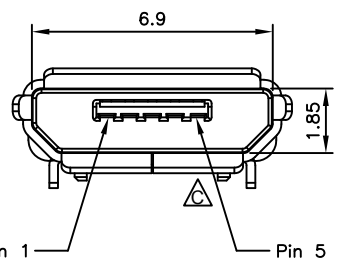
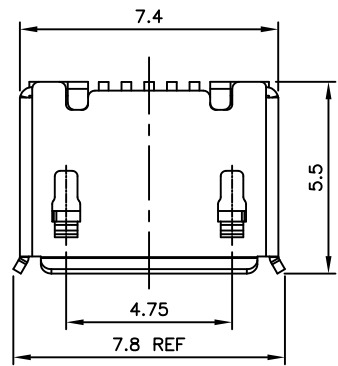
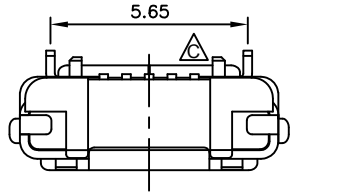
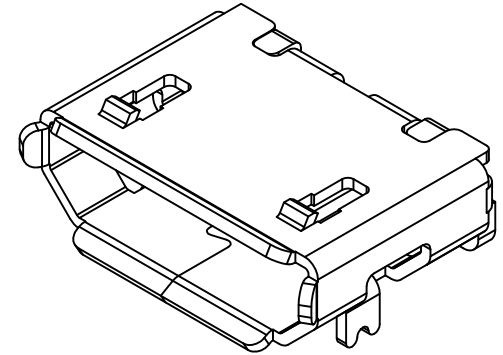
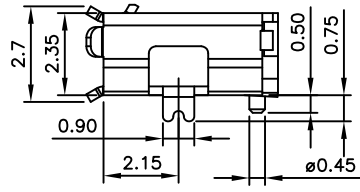

Ordering Grid

USB3080 - **30** - **XX** - **A** **REQUEST SAMPLES AND QUOTATION**

Contact Plating
 30 = 30u" Gold

Packing Options
 A = Tape & Reel
 (1.5K per Reel)

Optional Plastic Locating Peg
 00 = Without Peg
 01 = With Peg (Standard)

Specifications 规格:

Materials 材料:
 Plastic Housing 塑胶外壳: LCP, UL94V-0, Black, LCP, UL94V-0 黑色
 Contact Terminal 接触端子: Copper Alloy 铜合金
 Metallic Shell 金属外壳: Stainless Steel 不锈钢

Plating 电镀:
 Underplating 底层电镀: 50u" Nickel, 50u" 镍
 Finish 表面处理: Contact Area 接触面积: 30u" Gold plating, 30u" 镀金
 Solder Tails 焊接末端: Gold Flash 镀金
 Metallic Shell 金属外壳: Matte Tin 雾锡

Electrical 电气规格:
 Voltage Rating 电压额定值: 100 V AC
 Current Rating 电流额定值: Signal (Pins 2,3,4) 信号: 1.0 A. **B**
 Power (Pins 1,5) 电源: 1.8A.
 Operating Temperature 工作温度: -20°C to +85°C
 Contact Resistance 接触电阻值: 30mΩ Max.
 Insulating Resistance 绝缘电阻值: 1000MΩ Min.
 Dielectric Withstand Voltage 耐电压: 250V AC/Minute

Mechanical 机械性规格:
 Mating Force 插入力: 35N Max.
 Unmating Force 拔出力: 8N Min.
 Durability 耐久性: 10,000 Cycles 次插拔

By	SA	CM	ASE
DETAIL	DRAWING RELEASE	DRAWING UPDATE	AMENDED PEG
REV	A	B	C
DATE	04/04/11	26/10/11	17/02/12



Tolerances (Except as noted)	Part Number:-	Date:-
Dimensions in mm	USB3080	04 APR 11
X.X ± 0.4 X.X* ± 2°	Description:-	
X.XX ± 0.25 X.XX* ± 1°	μ USB RECEPTACLE, TYPE B, SMT, R/A, BOTTOM MOUNT, OPTIONAL PEG, WITH SHELL STAKES	
X.XXX ± 0.05 X.XXX* ± 0.5°		
Third Angle Projection	© THIS DRAWING IS CONFIDENTIAL AND MUST NOT BE COPIED OR DISCLOSED WITHOUT WRITTEN CONSENT	



www.globalconnectortechology.com				
Scale	Revision	Material	Drawn by	Sheet No.
NTS	C	See Note	SA	E & OE 1/2

Global Connector Technology Ltd. - USB3080: Micro USB Receptacle, Type B, SMT, Horizontal, Bottom Mount (Standard), with Optional Plastic Locating Peg and Inner Shell Stakes

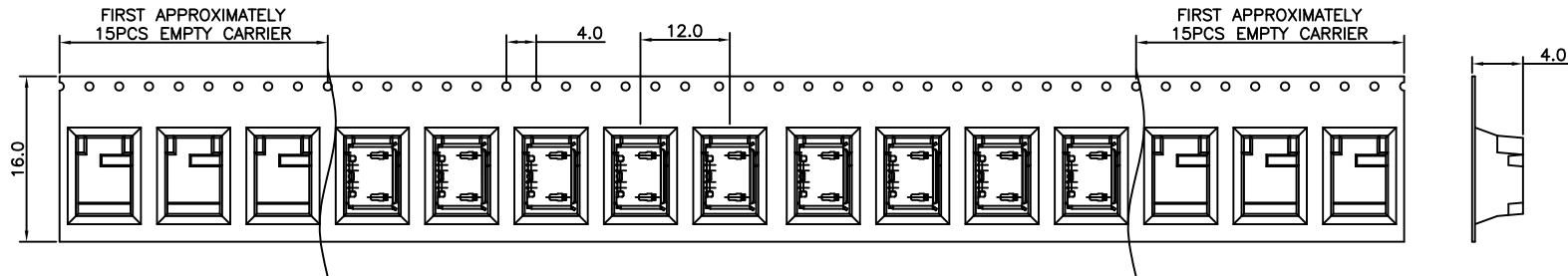

Products P/N	PCS/Reel	Reels/Carton	PCS/Carton
USB3080-30-XX-A	1500	5	7500

Notes 注意:

1. Peeling off force of top tape: 0.1-1.3N
2. Part Conforms to EIA-481-C Standards 产品符合EIA-481-C标准
3. All dimensions in millimeters 所有尺寸均是毫米
4. 10 sprocket hole pitch cumulative tolerance±0.2mm

I/O Direction
卷盤繞逆時針方向轉動

Cover Tape
盖带

Peel of Angle
剥皮角度

Carrier Tape
载带

Reel 卷筒

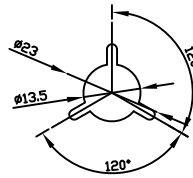

Detail F

Protection Tape
保护胶带

Label
标签

1500 pieces/reel
1500 件/卷

5 Reels
5 卷轴

700x600x0.08

Waterproof bag
防水袋

Cardboard
纸板

Triangle Liner
三角形班轮

Carton
纸箱

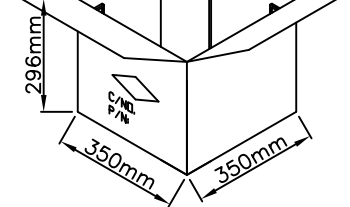

By	SA	CM	ASE
DETAIL	DRAWING RELEASE	DRAWING UPDATE	AMENDED PEG
REV DATE	A 04/04/11	B 26/10/11	C 17/02/12



Tolerances (Except as noted)	Part Number:- USB3080	Date:- 04 APR 11
Dimensions in mm	Description:- μ USB RECEPTACLE, TYPE B, SMT, R/A, BOTTOM MOUNT, OPTIONAL PEG, WITH SHELL STAKES	
Third Angle Projection	© THIS DRAWING IS CONFIDENTIAL AND MUST NOT BE COPIED OR DISCLOSED WITHOUT WRITTEN CONSENT	

GCT

www.globalconnectortechnology.com

Scale NTS	Revision C	Material See Note	Drawn by SA	E & OE	Sheet No. 2/2
--------------	---------------	----------------------	----------------	--------	------------------