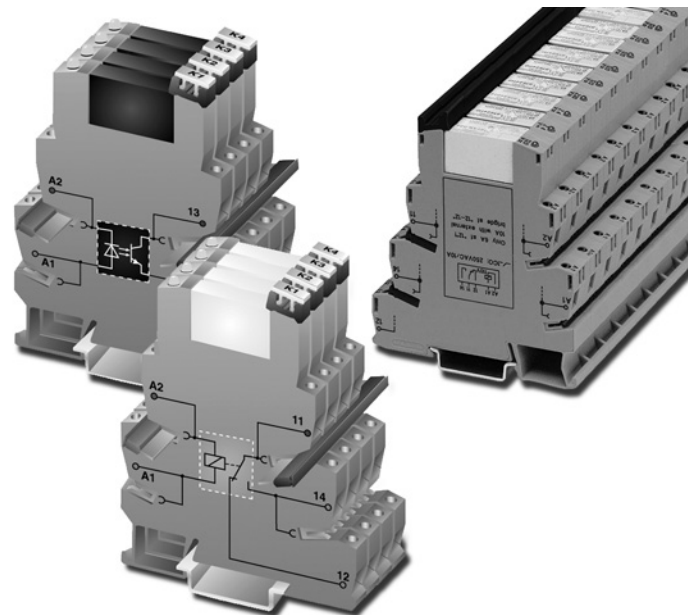


# XR Series Terminal Block Relays

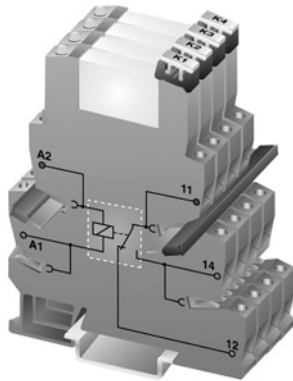
## Contents

<i>Description</i>	<i>Page</i>
Standard Terminal Block Relays .....	2
OptoCoupler Terminal Block Relays .....	7
High Current Terminal Block Relays .....	9
Accessories .....	11

**Note:** Supplement to Publication No. CA08102001E, Tab 49.



**XR Series Terminal Block Relays**



Standard Terminal  
Block Relay

## Product Description

The new **XR Series Terminal Block Relays** are ideal for applications that require a high switching capacity and long electrical service life. The relays are plug-in interfaces that connect to basic terminal blocks. The **XR Series** utilizes screw or spring-cage technology, as well as offers quick system wiring, superior safety features, clear labeling and a high level of modularity.

## Application Description

Used in automation systems, electro-mechanical relays guarantee a safe connection between process I/O and electronic controls. The following functions are covered by relay coupling elements:

- Electrical isolation between the input and output circuits
- Independence of the type of switching current (AC and DC)
- High short-term overload resistance in the event of short circuits or voltage peaks
- Low switching losses
- Ease of operation

## Features

- Pluggable relay allows for field replacement
- Functional plug-in bridges
- Choice of screw connections or spring-cage connection
- LED status indication
- DIN Rail Mount
- Only 6.2 mm wide for single pole versions, 14 mm wide for double pole
- All common input voltages between 12V DC to 120V AC

- Gold plated contacts available
- Equipped with a robust, miniature relay:
  - IP67 protection
  - Environmentally friendly, cadmium-free contact material
  - Easy, cost-effective installation and replacement using the engagement lever

## Standards and Specifications

- cUL<sub>US</sub> Listed
- CE

## Product Selection

Table 1. Standard Terminal Block Relays Product Selection

Gold Plated Contacts	Rated Current	Supply Voltage	Standard Pack	Catalog Number	Price U.S. \$
<b>1PDT Screw Connection</b>					
No	6A	12V DC	10	XRU1D12	19.50
No	6A	120V AC/110V DC	10	XRU1D120U	26.00
Yes	6A	120V AC/110V DC	10	XRU1D120UG	30.50
No	6A	24V DC	10	XRU1D24	19.50
No	6A	24V AC/DC	10	XRU1D24U	22.50
Yes	6A	24V AC/DC	10	XRU1D24UG	26.50
<b>1PDT Spring Cage Connection</b>					
No	6A	12V DC	10	XRP1D12	24.50
No	6A	120V AC/110V DC	10	XRP1D120U	31.00
No	6A	24V DC	10	XRP1D24	24.50
No	6A	24V AC/DC	10	XRP1D24U	27.50
<b>DPDT Screw Connection</b>					
No	6A	12V DC	10	XRU2D12	32.00
No	6A	120V AC/110V DC	10	XRU2D120U	40.00
No	6A	24V DC	10	XRU2D24	32.00
No	6A	24V AC/DC	10	XRU2D24U	35.00

Table 2. Standard Replacement Relays

Gold Plated Contacts	Rated Current	Supply Voltage	Standard Pack	Catalog Number	Price U.S. \$
<b>1PDT</b>					
No	6A	12V DC	10	XRR1D12	9.00
No	6A	120V AC/110V DC	10	XRR1D120U	14.00
Yes	6A	120V AC/110V DC	10	XRR1D120UG	17.00
No	6A	24V DC	10	XRR1D24	9.00
Yes	6A	24V DC	10	XRR1D24G	12.00
<b>DPDT</b>					
No	6A	12V DC	10	XRR2D12	9.00
No	6A	120V AC/110V DC	10	XRR2D120U	14.00
No	6A	24V DC	10	XRR2D24	9.00

Discount Symbol ..... 1CD1

March 2006

## Technical Data and Specifications

**Table 3. Standard 1PDT Screw Connection Terminal Block Relays Technical Data**

Catalog Number	XRU1D12	XRU1D24	XRU1D24U	XRU1D120U
Replacement Relay	XRR1D12	XRR1D24	XRR1D24	XRR1D120U
Input Voltage	12V DC	24V DC	24V AC/DC	120V AC/ 110V DC

### Connection Data

Rigid Solid AWG (mm <sup>2</sup> )	26 – 14 (0.14 – 2.5)			
Flexible Stranded AWG (mm <sup>2</sup> )	26 – 14 (0.14 – 2.5)			

### Input Data for 1PDT Screw Connection Versions

Input Voltage	12V DC	24V DC	24V AC/DC	120V AC/ 110V DC
Permissible Range See <b>Page 6</b>	See <b>Figure 5</b>	See <b>Figure 7</b>	See <b>Figure 8</b>	See <b>Figure 6</b>
Typical Input Current	15.3 mA	9 mA	11 mA (24V AC)/ 8.5 mA (24V DC)	3.5 mA (120V AC)/ 3 mA (110V DC)
Typical Response Time	5 mS	5 mS	6 mS	6 mS
Typical Release Time	8 mS	8 mS	15 mS	15 mS
Input Protection	Polarity Protection Diode, Free-Wheeling Diode		Bridge Rectifier	

### Output Data

Contact Type	1PDT
Contact Material	AgSnO
Max. Switching Voltage	250V AC/DC <sup>①</sup>
Min. Switching Voltage	12V AC/DC
Limiting Continuous Current	6A
Min. Switching Current	10 mA
Min. Switching Power	120 mW

### Miscellaneous Data

Test Voltage I/O	4 kV, 50 Hz, 1 min	4 kV	50 Hz
Ambient Temp Range	-4° to 140°F (-20° to 60°C)		
Rated Operating Mode	100% Operating Factor		
Inflammability Class	V0, in Accordance with UL 94		
Mechanical Service Life	2 x 10 <sup>7</sup> Cycles		

<sup>①</sup> The separating plate, XRAPLCEsk, should be installed for voltages greater than 250V (L1, L2, L3) between identical terminal points of adjacent modules. Potential bridging is then possible with the XRAFBST bridge system.

**Table 4. Standard 1PDT Screw Connection Terminal Block Relays with Gold Contacts Technical Data**

Catalog Number	XRU1D24UG	XRU1D120UG
Replacement Relay	XRR1D24G	XRR1D120UG
Input Voltage	24V AC/DC	120V AC/110V DC

### Connection Data

Rigid Solid AWG (mm <sup>2</sup> )	26 – 14 (0.14 – 2.5)	
Flexible Stranded AWG (mm <sup>2</sup> )	26 – 14 (0.14 – 2.5)	

### Input Data for 1PDT Screw Connection Versions with Gold Contacts

Input Voltage	24V AC/DC	120V AC/110V DC
Permissible Range See <b>Page 6</b>	See <b>Figure 8</b>	See <b>Figure 6</b>
Typical Input Current	11 mA (24V AC)/ 8.5 mA (24V DC)	3.5 mA (120V AC)/ 3 mA (110V DC)
Typical Response Time	6 mS	6 mS
Typical Release Time	15 mS	15 mS
Input Protection	Bridge Rectifier	

### Output Data

Contact Type	1PDT
Contact Material	AgSnO, Gold Plated <sup>②</sup>
Max. Switching Voltage	30V AC/36V DC (250V AC/DC) <sup>③</sup>
Min. Switching Voltage	100 mV (12V AC/DC) <sup>③</sup>
Limiting Continuous Current	50 mA (6A) <sup>③</sup>
Min. Switching Current	1 mA (10 mA) <sup>③</sup>
Min. Switching Power	100 (120 mW) <sup>③</sup>

### Miscellaneous Data

Test Voltage I/O	4 kV, 50 Hz, 1 min	50 Hz
Ambient Temp Range	-4° to 140°F (-20° to 60°C)	-40° to 131°F (-20° to 55°C)
Rated Operating Mode	100% Operating Factor	
Inflammability Class	V0, in Accordance with UL 94	
Mechanical Service Life	2 x 10 <sup>7</sup> Cycles	

<sup>②</sup> The separating plate, XRAPLCEsk, should be installed for voltages greater than 250V (L1, L2, L3) between identical terminal points of adjacent modules. Potential bridging is then possible with the XRAFBST bridge system.

<sup>③</sup> If the maximum values are exceeded, the gold layer is destroyed and the values in parentheses apply.

**Table 5. Standard 1PDT Spring Cage Terminal Block Relays Technical Data**

Catalog Number	XRP1D12	XRP1D24	XRP1D24U	XRP1D120U
Replacement Relay	XRR1D12	XRR1D24	XRR1D24	XRR1D120U
Input Voltage	12V DC	24V DC	24V AC/DC	120V AC / 110V DC

**Connection Data**

Rigid Solid AWG (mm <sup>2</sup> )	26 – 14 (0.14 – 2.5)			
Flexible Stranded AWG (mm <sup>2</sup> )	26 – 14 (0.14 – 2.5)			

**Input Data for 1PDT Spring Cage Versions**

Input Voltage	12V DC	24V DC	24V AC/DC	120V AC / 110V DC
Permissible Range See Page 6	See Figure 5	See Figure 7	See Figure 8	See Figure 6
Typical Input Current	15.3 mA	9 mA	11 mA (24V AC) / 8.5 mA (24V DC)	3.5 mA (120V AC) / 3 mA (110V DC)
Typical Response Time	5 mS	5 mS	6 mS	6 mS
Typical Release Time	8 mS	8 mS	15 mS	15 mS
Input Protection	Polarity Protection Diode, Free-Wheeling Diode		Bridge Rectifier	

**Output Data**

Contact Type	1PDT
Contact Material	AgSnO
Max. Switching Voltage	250V AC/DC ①
Min. Switching Voltage	12V AC/DC
Limiting Continuous Current	6A
Min. Switching Current	10 mA
Min. Switching Power	120 mW

**Miscellaneous Data**

Test Voltage I/O	4 kV, 50 Hz, 1 min	4 kV	50 Hz
Ambient Temp Range	-4° to 140°F (-20° to 60°C)		-4° to 131°F (-20° to 55°C)
Rated Operating Mode	100% Operating Factor		
Inflammability Class	V0, in Accordance with UL 94		
Mechanical Service Life	2 x 10 <sup>7</sup> Cycles		

① The separating plate, XRAPLCEsk, should be installed for voltages greater than 250V (L1, L2, L3) between identical terminal points of adjacent modules. Potential bridging is then possible with the XRAFBSST bridge system.

**Table 6. Standard DPDT Screw Connection Terminal Block Relays Technical Data**

Catalog Number	XRU2D12	XRU2D24	XRU2D24U	XRU2D120U
Replacement Relay	XRR2D12	XRR2D24	XRR2D24	XRR2D120U
Input Voltage	12V DC	24V DC	24V AC/DC	120V AC / 110V DC

**Connection Data**

Rigid Solid AWG (mm <sup>2</sup> )	26 – 14 (0.14 – 2.5)			
Flexible Stranded AWG (mm <sup>2</sup> )	26 – 14 (0.14 – 2.5)			

**Input Data**

Input Voltage	12V DC	24V DC	24V AC/DC	120V AC / 110V DC
Permissible Range See Page 6	See Figure 9	See Figure 11	See Figure 12	See Figure 10
Typical Input Current	33 mA	18 mA	17.5 mA	4.5 mA (120V AC) / 4.2 mA (110V DC)
Typical Response Time	8 mS	8 mS	8 mS	7 mS
Typical Release Time	10 mS			
Input Protection	Polarity Protection Diode, Free-Wheeling Diode		Bridge Rectifier	

**Output Data:**

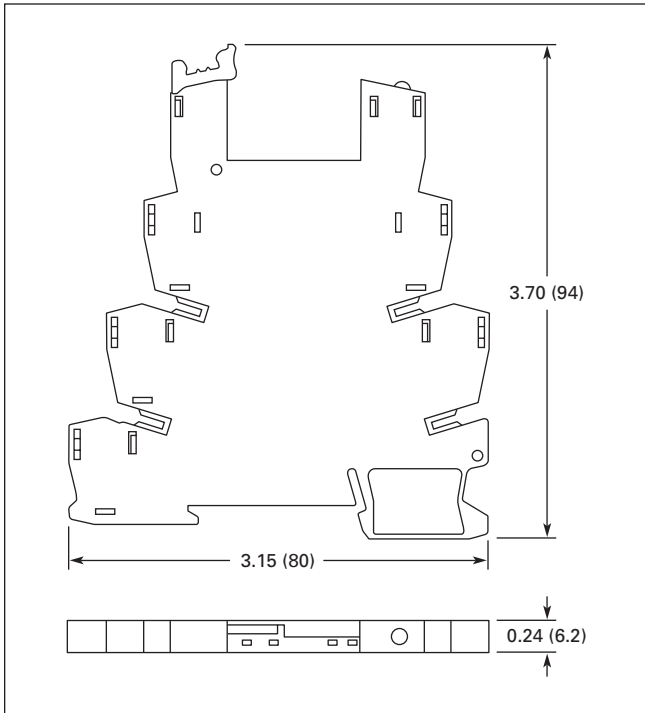
Contact Type	2PDT	Single Contact, 2PDT
Contact Material	AgNi	
Max. Switching Voltage	250V AC/DC	
Min. Switching Voltage	5V	
Limiting Continuous Current	6A	
Max. Inrush Current	15A (300 mS)	
Min. Switching Current	10 mA	
Min. Switching Power	50 mW	

**General Data**

Test Voltage I/O	4 kV, 50 Hz, 1 min / 2.5 kV, 50 Hz, 1 Min. (Between the PDTs)
Ambient Temp Range	-4° to 140°F (-20° to 60°C)
Rated Operating Mode	100% Operating Factor
Inflammability Class	V0, in Accordance with UL 94
Mechanical Service Life	3 x 10 <sup>7</sup> cycles

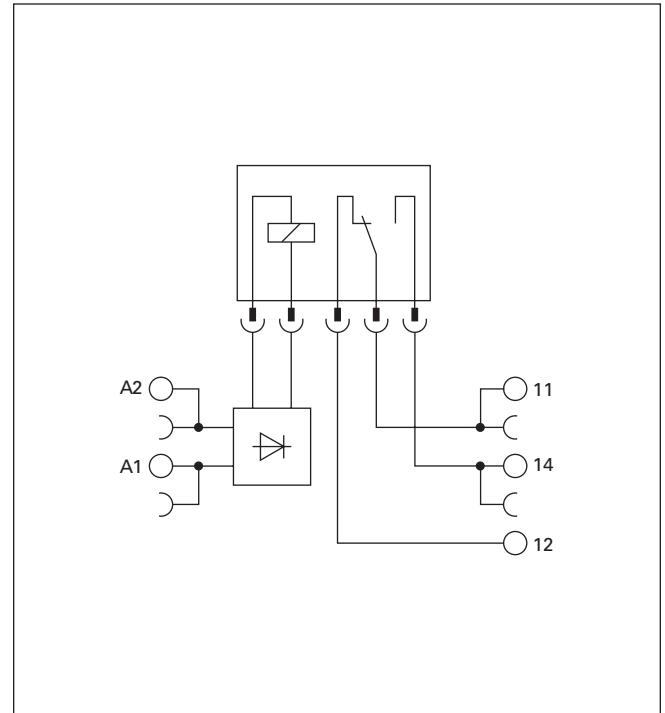
March 2006

**Dimensions**

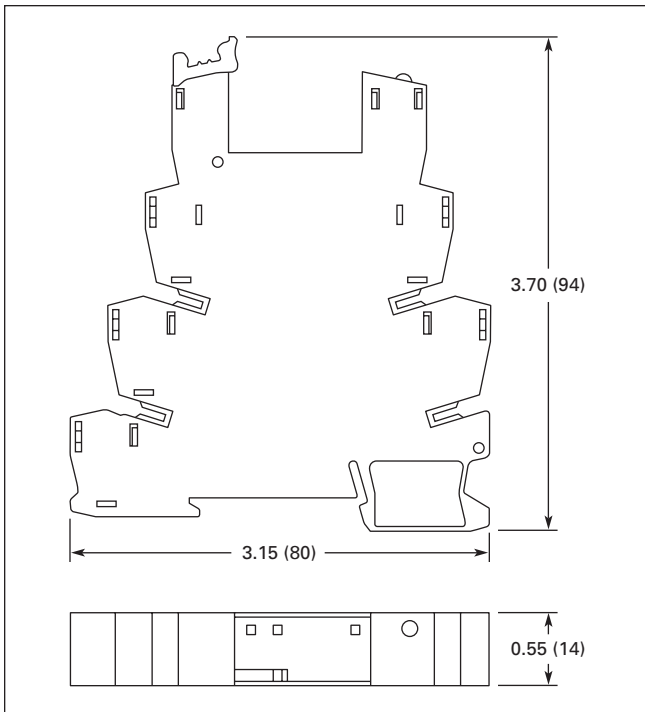


**Figure 1. Standard 1PDT Terminal Block Relays — Approximate Dimensions in Inches (mm)**

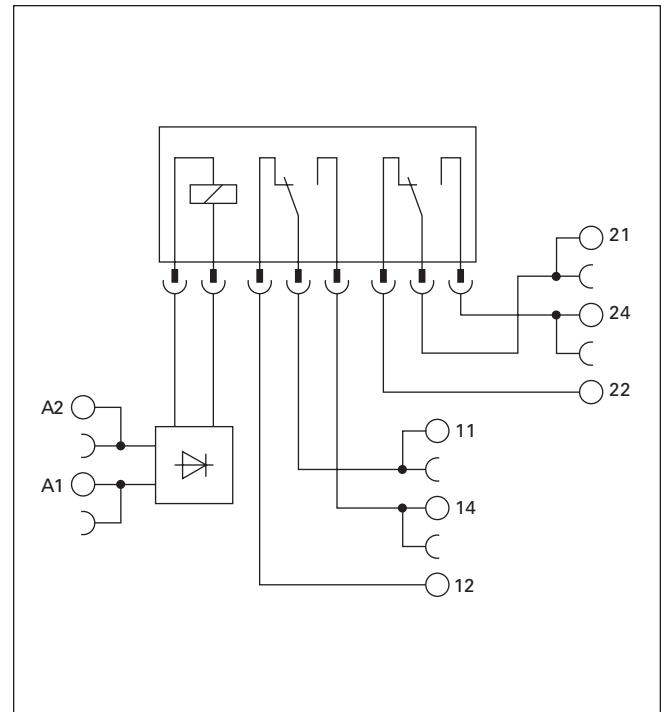
**Schematics**



**Figure 3. Schematics for 1PDT Terminal Block Relays**



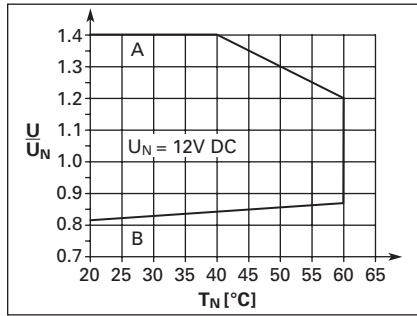
**Figure 2. Standard DPDT Terminal Block Relays — Approximate Dimensions in Inches (mm)**



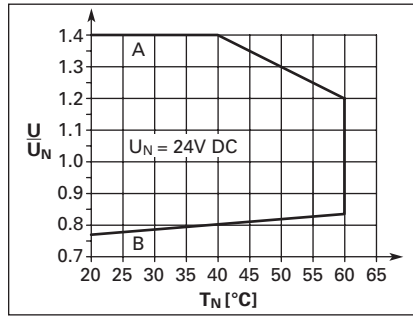
**Figure 4. Schematic for DPDT Terminal Block Relays**

**Permissible Range Diagrams**

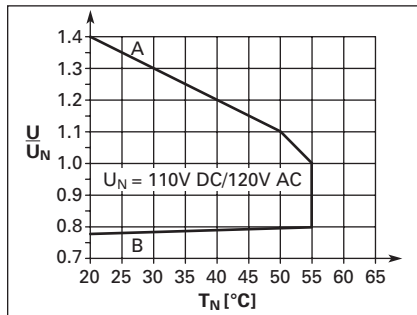
**1PDT**



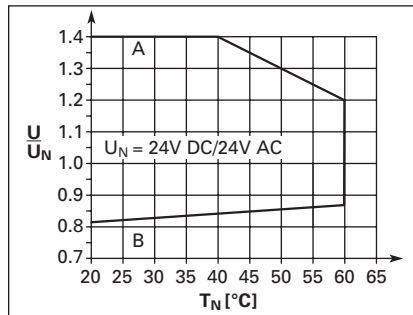
**Figure 5. Operating Range Voltage for 12V DC 1PDT Relay Module**



**Figure 7. Operating Range Voltage for 24V DC 1PDT Relay Module**



**Figure 6. Operating Range Voltage for 120V AC/110V DC 1PDT Relay Module**



**Figure 8. Operating Range Voltage for 24V AC/DC 1PDT Relay Module**

**Notes:**

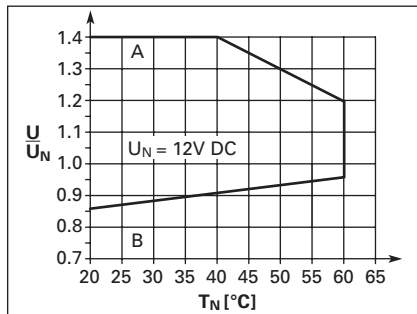
**General Conditions** — Direct alignment in the block, all devices 100% operating factor, horizontal or vertical mounting.

**Curve A** — Maximum permissible continuous operating voltage  $U_{max}$  with limiting continuous current on the contact side (see respective technical data).

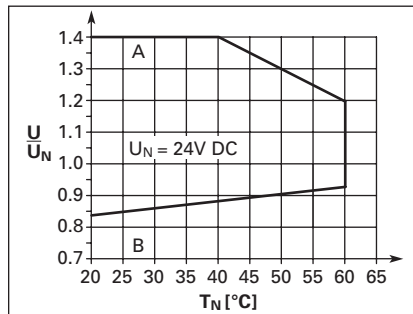
**Curve B** — Minimum permissible relay operate voltage  $U_{op}$  after pre-excitation ① (see respective technical data).

① Pre-excitation: Relay has been operated in a thermally steady state at the ambient temperature  $T_U$  with nominal voltage  $U_N$  and limiting continuous current on the contact side (see respective technical data) (warm coil). After being switched off for a short time, the relay must reliably pick up again at  $U_{op}$ .

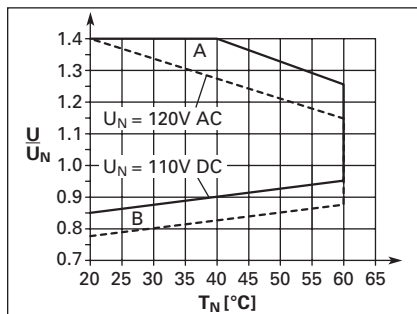
**DPDT**



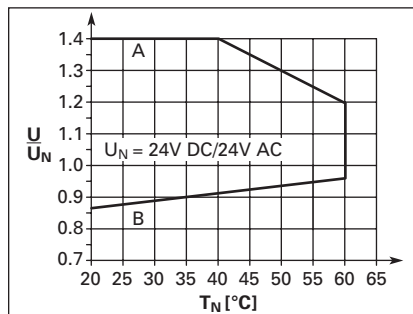
**Figure 9. Operating Range Voltage for 12V DC DPDT Relay Module**



**Figure 11. Operating Range Voltage for 24V DC DPDT Relay Module**

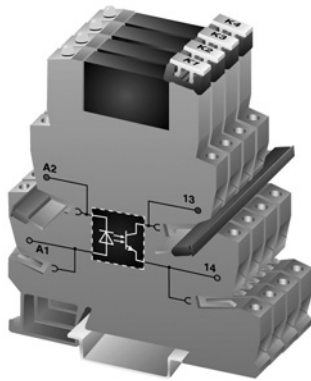


**Figure 10. Operating Range Voltage for 120V AC/110V DC DPDT Relay Module**



**Figure 12. Operating Range Voltage for 24V AC/DC DPDT Relay Module**

March 2006



*OptoCoupler Terminal Block Relay*

**Product Description**

The new **XR** Series OptoCoupler Terminal Block Relays can be used in all applications and consist of a pluggable miniature OptoCoupler and a basic terminal block. The **XR** Series utilizes screw or spring-cage technology, as well as offers quick system wiring, superior safety features, clear labeling and a high level of modularity.

**Application Description**

The **XR** Series OptoCoupler relays can be used as an input or output interface. They provide the typical reliability of OptoCouplers and are especially suited for high operating frequencies.

**Features**

- Pluggable relay allows for field replacement
- Functional plug-in bridges
- LED status indication
- DIN Rail Mount
- Only 6.2 mm wide
- Switching capacity up to 24V DC/3A
- IP67-protected optical electronics

- Wear-resistant and bounce-free switching
- Insensitive to shock and vibration
- Integrated protection circuit
- Zero voltage switch at AC output

**Standards and Certifications**

- cUL<sub>US</sub> Listed
- CE

**Product Selection**

**Table 7. OptoCoupler Terminal Block Relays Product Selection**

Rated Current	Supply Voltage	Standard Pack	Catalog Number	Price U.S. \$
2A	120V AC/110V DC	10	XRU1S120U	58.00
2A	24V DC	10	XRU1S24	55.00

**Table 8. OptoCoupler Replacement Relays**

Rated Current	Supply Voltage	Standard Pack	Catalog Number	Price U.S. \$
2A	24V DC	18	XRR1S24	45.00
2A	120V AC/110V DC	10	XRR1S120U	48.00

Discount Symbol ..... 1CD1

## Technical Data and Specifications

**Table 9. Pluggable Power OptoCoupler (Solid-State) Terminal Block Relays Technical Data**

Catalog Number	XRU1S24	XRU1S120U
Replacement Relay	XRR1S24	XRR1S120U
Input Voltage	24V DC	120V AC/110V DC

### Connection Data

Rigid Solid AWG (mm <sup>2</sup> )	26 – 14 (0.14 – 2.5)
Flexible Stranded AWG (mm <sup>2</sup> )	26 – 14 (0.14 – 2.5)

### Input Data

Input Voltage	24V DC	120V AC/110V DC
Permissible Range	0.8 – 1.2	0.8 – 1.1
Typical input current	9 mA	4 mA
Switching Level 1 signal ("H")	≥ 0.8	≥ 0.8
Switching Level 0 signal ("L")	≤ 0.4	≤ 0.25
Typical Switch-On Time	20 μS	6 mS
Typical Turn-Off Time	500 μS	10 mS
Input Protection	Polarity Protection Diode, Free- Wheeling Diode	Bridge Rectifier

### Output Data

Max. Switching Voltage	33V DC	33V DC
Min. Switching Voltage	3V DC	3V DC
Limiting Continuous Current	3A (See Figure 13)	
Max. Inrush Current	15A (10 mS)	
Output Circuit	2-Conductor Floating	
Output Protection	Polarity Protection, Surge Protection	
Voltage Drop at Max. Limiting Continuous Current	≤ 200 mV	

### General Data

Test Voltage I/O	2.5 kV, 50 Hz, 1 min
Ambient Temp Range	-4° to 140°F (-20° to 60°C)
Rated Operating Mode	100% Operating Factor
Inflammability Class	V0, in Accordance with UL 94
Mechanical Service Life	2 x 10 <sup>7</sup> cycles

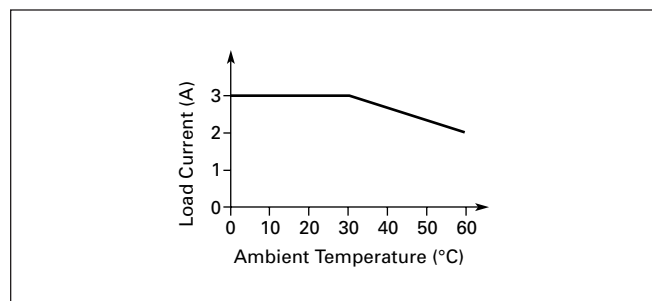


Figure 13. Derating Curve

## Dimensions

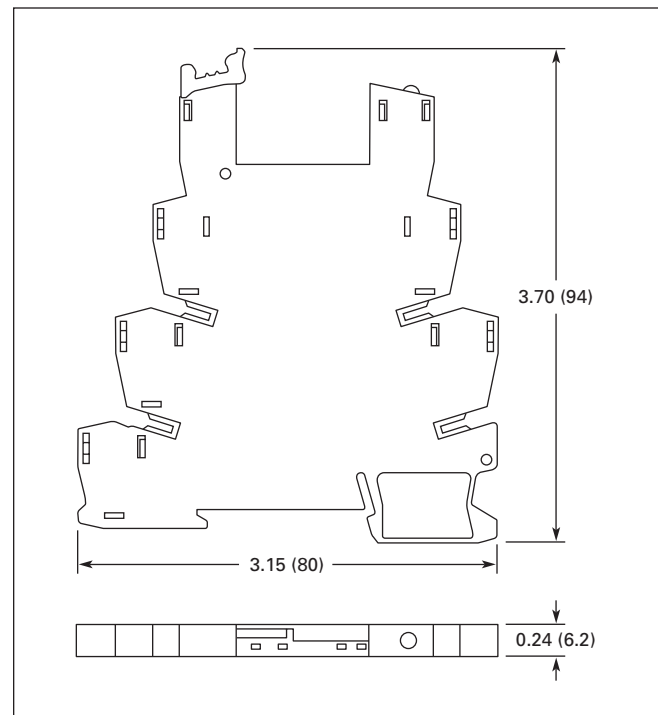


Figure 14. Pluggable Power OptoCoupler (Solid-State) Terminal Block Relays — Approximate Dimensions in Inches (mm)

## Schematic

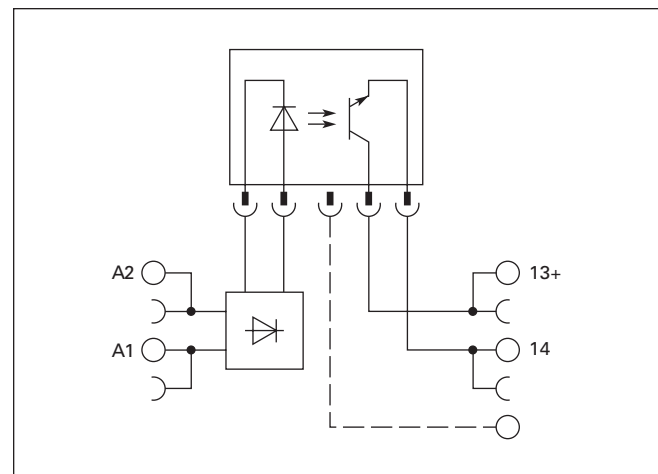
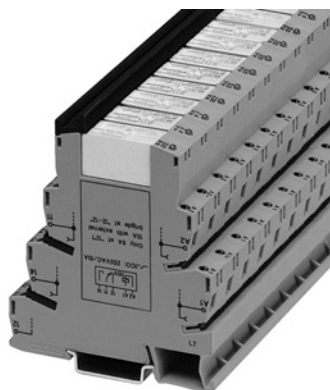


Figure 15. Schematic for Pluggable Power OptoCoupler (Solid-State) Terminal Block Relays





**High Current Terminal Block Relay**

**Product Description**

The new **XR Series Relays** include products designed to meet high continuous current and/or long electrical service life applications. The **XR Series Relays** are plug-in interfaces that connect to basic terminal blocks that use screw connection technology. Overall width is 14 mm.

**Application Description**

These relays are best suited for applications that require higher continuous load currents than miniature relays can carry and switch. They can withstand inrush currents or brief overloads without damage, and allow for continuous load currents of up to 10A. The **XR Series Relay** boasts an average service life of the contacts that is two or three times the normal life of a less powerful relay, resulting in service cost savings.

**Features**

- 14 mm wide
- Pluggable relay allows for field replacement
- Convenient plug-in bridge system
- LED status indication
- DIN Rail Mount
- IP67-protected optical electronics
- Wear-resistant and bounce-free switching

- Insensitive to shock and vibration
- Integrated protection circuit
- Zero voltage switch at AC output
- Environmentally friendly, cadmium-free contact material
- Electrical isolation between input and output

**Standards and Certifications**

- cUL<sub>us</sub> Listed
- CE

**Product Selection**

**Table 10. High Current Terminal Block Relays Product Selection**

Rated Current	Supply Voltage	Standard Pack	Catalog Number	Price U.S. \$
10A	12V DC	10	XRU1H12	28.50
10A	120V AC/110V DC	10	XRU1H120U	35.00
10A	24V DC	10	XRU1H24	28.50
10A	24V AC/DC	10	XRU1H24U	30.00

**Table 11. High Current Replacement Relays**

Rated Current	Supply Voltage	Standard Pack	Catalog Number	Price U.S. \$
10A	24V DC	10	XRR1H24	13.00
10A	24V AC/DC	10	XRR1H24U	13.50
10A	12V DC	10	XRR1H12	13.00
10A	120V AC/110V DC	10	XRR1H120U	16.00

Discount Symbol ..... 1CD1

## Technical Data and Specifications

**Table 12. Information for High Current Terminal Block Relays (1PDT)**

Catalog Number — Assembled Unit	XRU1H12	XRU1H24	XRU1H24U	XRU1H120U
Replacement Relay	XRR1H12	XRR1H24	XRR1H24U	XRR1H120U
Input Voltage	12V DC	24V DC	24V AC/DC	120V AC/ 110V DC

### Connection Data

Rigid Solid AWG (mm <sup>2</sup> )	26 – 14 (0.14 – 2.5)
Flexible Stranded AWG (mm <sup>2</sup> )	26 – 14 (0.14 – 2.5)

### Input Data (Permissible Range — See Page 6)

Input Voltage	12V DC	24V DC	24V AC/DC	120V AC/ 110V DC
Permissible Range See Page 6	See Figure 9	See Figure 11	See Figure 12	See Figure 10
Typical Input Current	33 mA	18 mA	17.5 mA	4.5 mA (120V AC)/ 4.2 mA (110V DC)
Typical Response Time	8 mS	8 mS	8 mS	7 mS
Typical Release Time	10 mS			
Input Protection	Polarity Protection Diode, Free-Wheeling Diode		Bridge Rectifier	

### Output Data

Contact Type	Single Contact, 1PDT
Contact Material	AgNi
Max. Switching Voltage	250V AC/DC ①
Min. Switching Voltage	12V AC/DC
Limiting Continuous Current	10A (6)A ②
Max. Inrush Current	30A (300 mS)
Min. Switching Current	100 mA
Min. Switching Power	1.2W

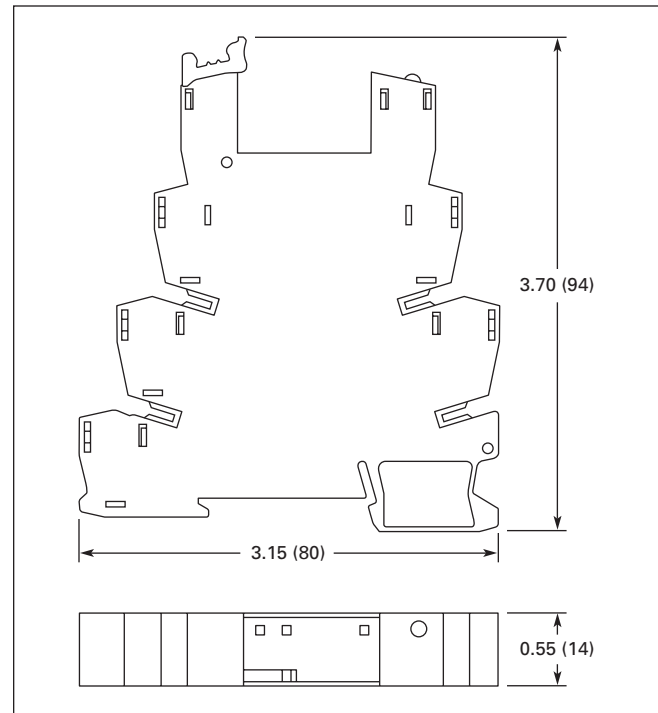
### Miscellaneous Data

Test Voltage I/O	4 kV, 50 Hz, 1 min
Ambient Temp Range	-4° to 140°F (-20° to 60°C)
Rated Operating Mode	100% Operating Factor
Inflammability Class	V0, in Accordance with UL 94
Mechanical Service Life	3 x 10 <sup>7</sup> cycles

① The separating plate, XRAPLCEK, should be installed for voltages greater than 250V (L1, L2, L3) between identical terminal points of adjacent modules. Potential bridging is then possible with the XRAFBST bridge system.

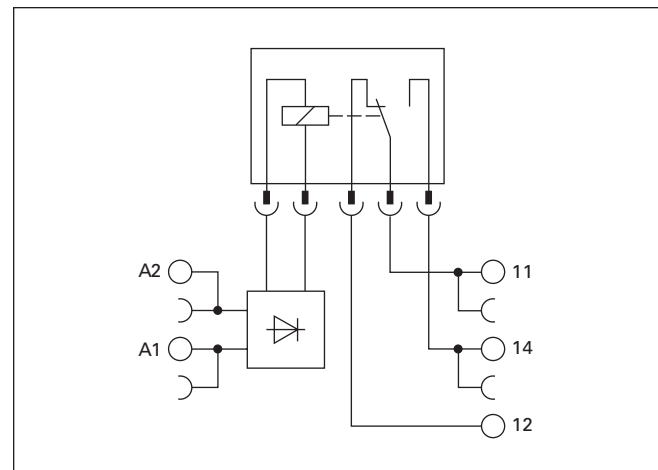
② The current rating for the normally open contact (#14) is 10A. The current rating for the normally closed contact (#12) is 6A and can be increased to 10A by bridging the two #12 contact connections.

## Dimensions



**Figure 16. High Current Terminal Block Relays — Approximate Dimensions in Inches (mm)**

## Schematic



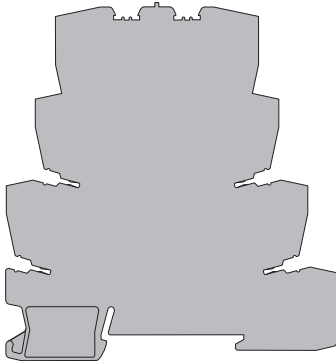
**Figure 17. Schematic for High Current Terminal Block Relays**

March 2006

**Product Description**

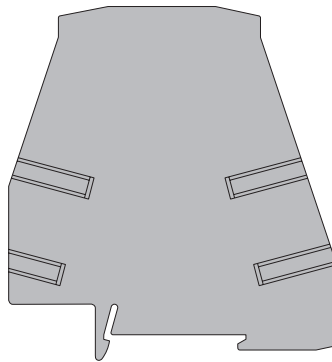
**Power Terminal Block**

The XRAPLCEK power terminal block has the same shape as the relay modules and is used to feed in the bridging potentials. The nominal current is 32A. When the total current is less than or equal to 6A, supply can take place directly at the connecting terminal blocks of one of the connected relays.



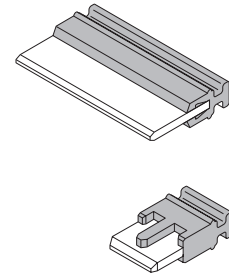
**End Cover**

The XRAATPBK end cover is required at the start and stop of a relay strip. It can also be used for visual separation of groups of relays as well as separating relays with voltages greater than 250V and separating neighboring bridges with different potentials. It is equipped with pre-scored break out points at the bridging positions so that individual bridges can be passed through as needed. It may also be necessary to use the end cover between adjacent relays when three phases (L1, L2, L3) are used on the contact side of the relay.



**Bridges**

The XRAFBST colored, insulated plug-in bridge system reduces wiring time by up to 70% compared to conventionally wired relays. The XRAFBST2, 2-position bridges, are suited for bridging a smaller number of relays and total currents ≤ 6A. When a circuit is supplied from both sides, the circuit can be opened at any point, allowing all other modules to continue being supplied at the same time. The XRAFBST500 allow up to 80 modules to be bridged at one time. If bridges with different potentials meet in neighboring modules, the end cover XRAATPBK should be used. All bridges are equipped with a groove for removal with a standard screwdriver.



**Product Selection**

**Table 13. Product Selection Table for XR Series Accessories**

Description	Color	Standard Pack	Catalog Number	Price U.S. \$
2-Position Snap-In Jumper	Red	10	XRAFBST2RD	1.40
2-Position Snap-In Jumper	Blue	10	XRAFBST2BU	1.40
2-Position Snap-In Jumper	Gray	10	XRAFBST2GY	1.40
80-Position Snap-In Jumper	Red	5	XRAFBST500RD	22.00
80-Position Snap-In Jumper	Blue	5	XRAFBST500BU	22.00
80-Position Snap-In Jumper	Gray	5	XRAFBST500GY	22.00
Power Terminal Block	Gray	5	XRAPLCEK	27.00
End Cover	Black	5	XRAATPBK	5.75

**Table 14. Power Terminal Block Technical Specifications**

Description	Specification
<b>Connection Data</b>	
Rigid Solid AWG (mm <sup>2</sup> )	24 – 10 (0.2 – 4)
Flexible Stranded AWG (mm <sup>2</sup> )	24 – 10 (0.2 – 4)
<b>Miscellaneous Data</b>	
Max. Current	32A
Max. Voltage	250V AC <sup>①</sup>
Approvals	c  us

<sup>①</sup> The separating plate, XRAPLCEK, should be installed for voltages greater than 250V (L1, L2, L3) between identical terminal points of adjacent modules. Potential bridging is then possible with the XRAFBST bridge system.

Discount Symbol ..... 1CD1

Eaton Electrical Inc.  
1000 Cherrington Parkway  
Moon Township, PA 15108-4312  
USA  
tel: 1-800-525-2000  
[www.EatonElectrical.com](http://www.EatonElectrical.com)



© 2006 Eaton Corporation  
All Rights Reserved  
Printed in USA  
Publication No. CA04900001E/CPG  
March 2006