

Designed to comply with physical, electrical and environmental requirements of full size USB Standard Compliance (USB3.0).

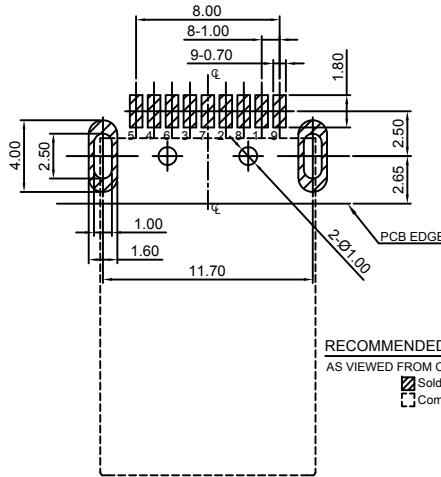

RECOMMENDED P.C.B LAYOUT
AS VIEWED FROM COMPONENT SIDE

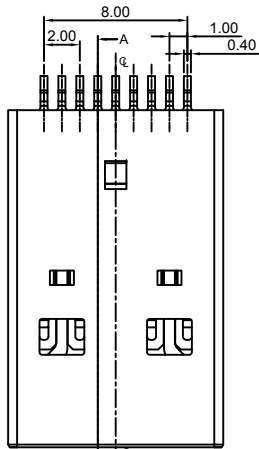
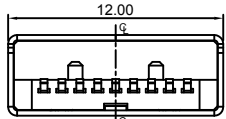
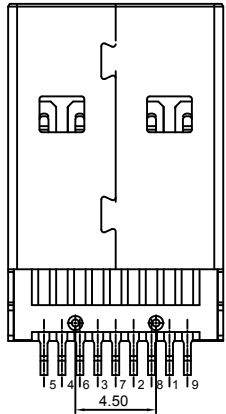
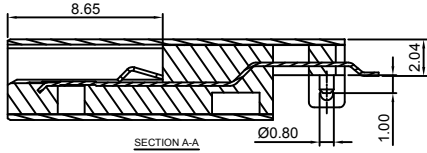
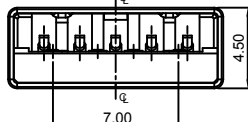
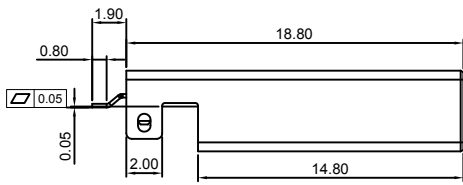
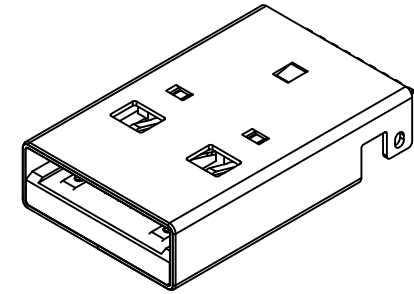
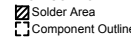

Ordering Grid
USB1065 - **30** - **A** **REQUEST SAMPLES AND QUOTATION**

Contact Plating
30 = 30µ" Gold

Packing Options
A = Tape & Reel
(0.9K per Reel) **B**

Specifications 规格:

Materials 材料:

Plastic Housing 塑胶外壳: LCP, UL94V-0, Blue 黑色
Contact Terminal 接触端子: Copper Alloy 铜合金
Metallic Shell 金属外壳: SPCC

Finish 表面处理:

Underplating 底层电镀: Nickel
Plating 电镀:

Contact Area 接触面积: 30µ" Gold
Solder Tails 焊接末端: 100µ" Min. Tin
Metallic Shell 金属外壳: Nickel

Electrical 电气规格:

Voltage Rating 电压额定值: 30 V AC
Current Rating 电流额定值: 1.8A AC/DC
Operating Temperature 工作温度: -20°C to +80°C
Contact Resistance 接触电阻值: 30mΩ Max.
Insulating Resistance 绝缘电阻值: 500MΩ Min.
Dielectric Withstand Voltage 耐电压: 500V AC/Minute

Mechanical 机械性规格:

Mating Force 插入力: 35N Max.
Unmating Force 拨出力: 10N Min.
Durability 耐久性: 5000

By	ASE	ASE
DETAIL	DRAWING RELEASE	PACKING AMENDED
REV DATE	A 09/05/11	B 20/02/12



Tolerances (Except as noted)	Part Number:-	Date:-
Dimensions in mm	USB1065	09 MAY 11
X.X ± 0.4	X.X° ± 2°	Description:- USB 3.0 PLUG, TYPE A, SMT, HORIZONTAL, 9 PIN, TOP MOUNT W/PLASTIC LOCATING PEGS & OUTER SHELL STAKES
X.XX ± 0.25	X.XX° ± 1°	
X.XXX ± 0.05	X.XXX° ± 0.5°	
Third Angle Projection	THIS DRAWING IS CONFIDENTIAL AND MUST NOT BE COPIED OR DISCLOSED WITHOUT WRITTEN CONSENT	Scale NTS



www.globalconnectortechnology.com

Revision B	Material See Note	Drawn by ASE	E & OE	Sheet No. 1/2
------------	-------------------	--------------	--------	---------------

Global Connector Technology Ltd. - USB1065: USB 3.0 Plug, Type A, SMT, Horizontal, 9 Pin, Top Mount, W/Plastic Locating Pegs & Outer Shell Stakes

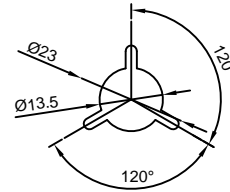
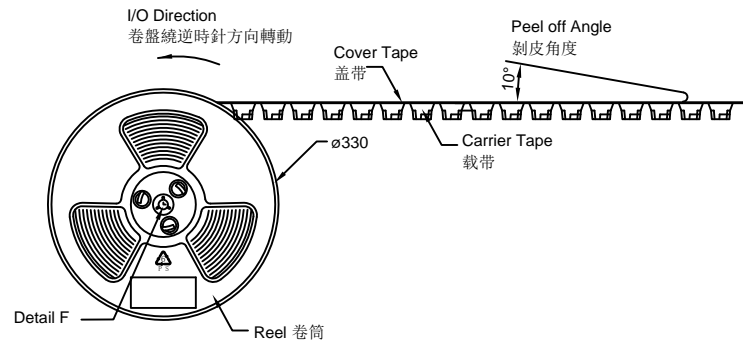
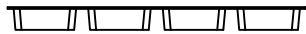
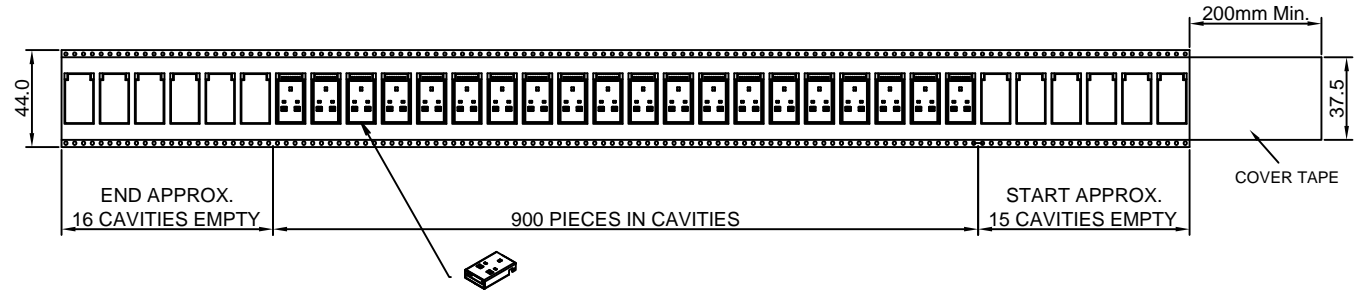
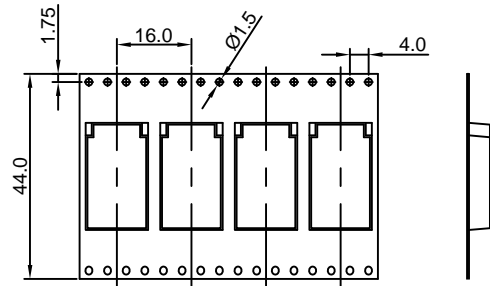

Products P/N	PCS/Reel	Reels/Carton	PCS/Carton
USB1065-30-A	900	5	4500

- Notes注意:
1. Peeling off force of top tape: 0.1-1.3N
 2. Part Conforms to EIA-481-C Standards 产品符合EIA-481-C标准
 3. All dimensions in millimeters 所有尺寸均是毫米

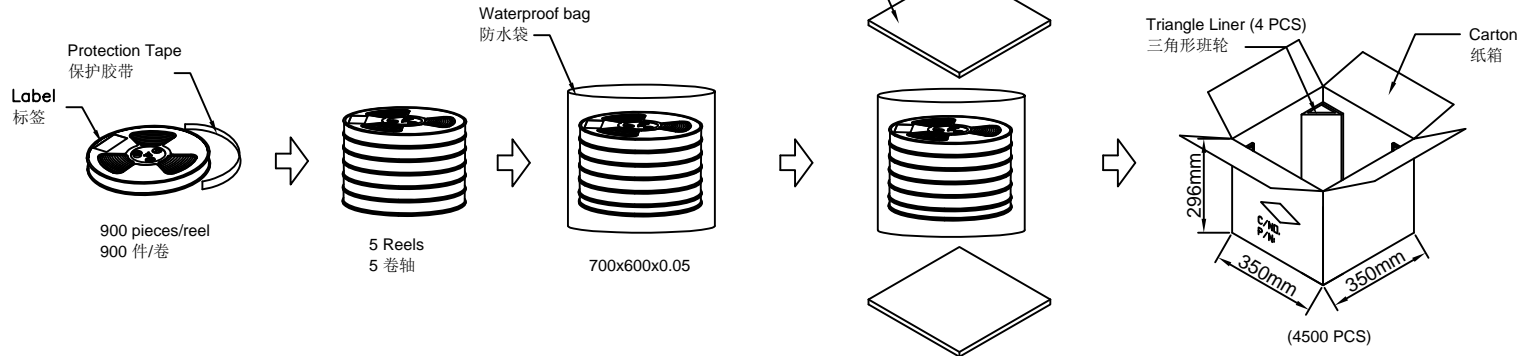

By	ASE	ASE
DETAIL	DRAWING RELEASE	PACKING AMENDED
REV DATE	A 09/05/11	B 20/02/12



Tolerances (Except as noted)		Part Number:-	Date:-
Dimensions in mm		USB1065	09 MAY 11
X.X ± 0.4	X.X° ± 2°	Description:-	
X.XX ± 0.25	X.XX° ± 1°	USB 3.0 PLUG, TYPE A, SMT, HORIZONTAL, 9 PIN, TOP MOUNT W/PLASTIC LOCATING PEGS & OUTER SHELL STAKES	
X.XXX ± 0.05	X.XXX° ± 0.5°	© THIS DRAWING IS CONFIDENTIAL AND MUST NOT BE COPIED OR DISCLOSED WITHOUT WRITTEN CONSENT	
Third Angle Projection		Scale NTS	Revision B

GCT

www.globalconnectortechology.com

Material	Drawn by	Sheet No.
See Note	ASE	E & OE 2/2