



PART NO.

MC0002 - Series

REVISIONS

ECN #	REV	DESCRIPTION	DRAWN	DATE	CHECKD	DATE	APPRVD	DATE
-	A	RELEASED	Asha	12/10/11	Veena	12/10/11		24/10/11

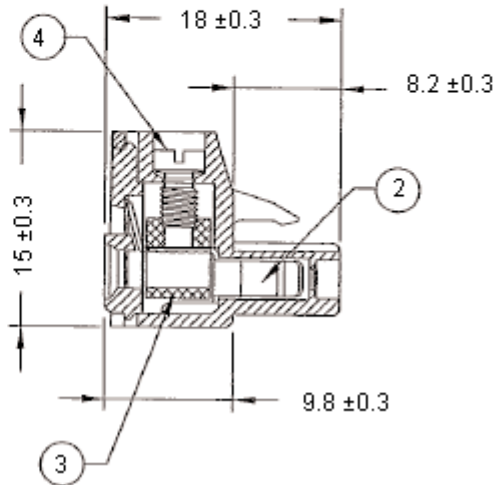
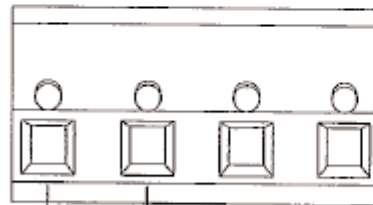
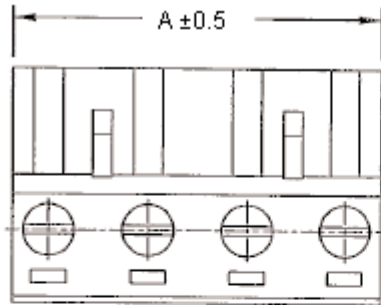

Dimensions : Millimetres

Specifications:

Current rating	: 15 amperes, 300 V ac
Minimum insulation withstand voltage	: 2,000 V ac
Insulation resistance	: > 2,000 MΩ 500 V dc
Operating temperature	: -40°C to +105°C
Wire strip length	: 4 to 5 mm
Wire range	: 14 to 24 AWG
Screw torque	: 4.5 lb-inch

Important Notice : This data sheet and its contents (the "Information") belong to the members of the Premier Farnell group of companies (the "Group") or are licensed to it. No licence is granted for the use of it other than for information purposes in connection with the products to which it relates. No licence of any intellectual property rights is granted. The Information is subject to change without notice and replaces all data sheets previously supplied. The Information supplied is believed to be accurate but the Group assumes no responsibility for its accuracy or completeness, any error in or omission from it or for any use made of it. Users of this data sheet should check for themselves the information and the suitability of the products for their purpose and not make any assumptions based on information included or omitted. Liability for loss or damage resulting from any reliance on the Information or use of it (including liability resulting from negligence or where the Group was aware of the possibility of such loss or damage arising) is excluded. This will not operate to limit or restrict the Group's liability for death or personal injury resulting from its negligence. Multicomp is the registered trademark of the Group. © Premier Farnell plc 2011.

TOLERANCES:

UNLESS OTHERWISE SPECIFIED, DIMENSIONS ARE FOR REFERENCE PURPOSES ONLY.

DRAWN BY:	DATE:
Asha	12/10/11
CHECKED BY:	DATE:
Veena	12/10/11
APPROVED BY:	DATE:
	26/10/11

DRAWING TITLE:			
7.62 mm Pluggable - Straight Plug			
SIZE	DWG NO.	ELECTRONIC FILE	REV
A	M10002719	MC100-762-B_DWG	A
SCALE: NTS		U.O.M.: mm (Inches)	SHEET: 1 OF 2



PART NO.

MC0002 - Series

REVISIONS

ECN #	REV	DESCRIPTION	DRAWN	DATE	CHECKD	DATE	APPRVD	DATE
-	A	RELEASED	Asha	12/10/11	Veena	12/10/11		24/10/11

Specification Table

Item No	Material		Plating / Finish	Remark
1	Insulating Body	Polyamide 66	-	Green
2	Contact	Phosphor Bronze	Tin plated	-
3	Cage Clamp	Brass	Ni plated	-
4	Screw	Steel	Zinc+Cr ⁺³	-

Dimensions Table

Pitch : 7.62 mm (0.3 inch)		
Poles	A (mm)	A (Inch)
2	13.22	0.52
3	20.84	0.82
4	28.46	1.12
5	36.08	1.42
6	43.7	1.72
8	58.94	2.32
10	74.18	2.92
12	89.42	3.52

Part Number Table

Description	Part Number
Plug 7.62 mm Straight 16A 02 Way	MC000216
Plug 7.62 mm Straight 16A 03 Way	MC000217
Plug 7.62 mm Straight 16A 04 Way	MC000218
Plug 7.62 mm Straight 16A 05 Way	MC000219
Plug 7.62 mm Straight 16A 06 Way	MC000220
Plug 7.62 mm Straight 16A 08 Way	MC000221
Plug 7.62 mm Straight 16A 10 Way	MC000222
Plug 7.62 mm Straight 16A 12 Way	MC000223

www.element14.com
www.farnell.com
www.newark.com

Important Notice : This data sheet and its contents (the "Information") belong to the members of the Premier Farnell group of companies (the "Group") or are licensed to it. No licence is granted for the use of it other than for information purposes in connection with the products to which it relates. No licence of any intellectual property rights is granted. The Information is subject to change without notice and replaces all data sheets previously supplied. The Information supplied is believed to be accurate but the Group assumes no responsibility for its accuracy or completeness, any error in or omission from it or for any use made of it. Users of this data sheet should check for themselves the information and the suitability of the products for their purpose and not make any assumptions based on information included or omitted. Liability for loss or damage resulting from any reliance on the Information or use of it (including liability resulting from negligence or where the Group was aware of the possibility of such loss or damage arising) is excluded. This will not operate to limit or restrict the Group's liability for death or personal injury resulting from its negligence. Multicomp is the registered trademark of the Group. © Premier Farnell plc 2011.

TOLERANCES: UNLESS OTHERWISE SPECIFIED, DIMENSIONS ARE FOR REFERENCE PURPOSES ONLY.	DRAWN BY:	DATE:	DRAWING TITLE: 7.62 mm Pluggable - Straight Plug			
	Asha	12/10/11				
	CHECKED BY:	DATE:	SIZE A	DWG NO. M10002719	ELECTRONIC FILE MC100-762-B_DWG	REV A
	Veena	12/10/11				
APPROVED BY:	DATE:	SCALE: NTS		U.O.M.: mm (Inches)		SHEET: 2 OF 2
	26/10/11					