

Specification for Approval

Customer :

Part Name : AC ADAPTER

Description : 15.0 Volts / 0.5 Amps

Model No. : STD-15005B(U.K./ Level V)

P / N : SW3521

Product P / N : RXTD15005B418201

Issued Date : 05-Aug.-2010

Version : A1

Issued Stamp :

Customer's Approval Signature

7.5W
Switching Power Adapter
SPECIFICATION

Model No. : **STD-15005B(U.K./Level V)**

Description : **15.0 Volts / 0.5 Amps**

Part No. : **RXTD15005B418201**

Version : **A1**

Date : **05-Aug.-2010**

Approved	Checked	Prepared

■ Approval Documents/Spec. Revised Records

■ Customer : PowerPax UK

■ Model No. : STD-15005B

■ Original Documents Content : SPEC. 11 Page(s), Attachment 2 Pages

Revised Records : No.	Date (mm/dd/yyyy)	Description (Before / After)	Page(s) Revised	Revised By (Adapter/Customer)	Remark
1	Feb./04/2008	ISSUE		Chihwei	1.0
2	Dec./01/2009	Label revise P/N: to SW3521	P1,P7,P8	Chihwei	1.1
3	Dec./01/2009	FERRITE CORE FROM BIG TO SMALL	P6,A1	Chihwei	1.1
4	Aug./05/2010	Version updated to LEVEL V	P1,P2,P4,P7 P9-11	Chihwei	A1
5					
6					
7					
8					
9					
10					
11					
12					
13					
14					
15					

1. Feature :

- ◆ **Input** : **Universal 100 ~ 240 Vac / 47 ~ 63 Hz Input, without any slide switch.**
- ◆ **Output** : **+15.0V / 0~0.5A**
- ◆ **Case Dimension** : **52 (L) * 50 (W) * 72.5 (H) mm**
- ◆ **Efficiency** : **Eff (av) \geq 74.89%**
- ◆ **Safety** : **CE / CB**
- ◆ **EMI** : **CE /EMC Class B ; Conduction & Radiation Meet.**
- ◆ **Protection** : **OVP(Over Voltage Protection) 、SCP(Short Circuit Protection)
OCP (Over Current Protection)**
- ◆ **High frequency design , less power consumption.**
- ◆ **Suitable for usage at Telecommunication, Computer, Industrial Controller, & OA System.**
- ◆ **Meet Energy Star V / Erp (Stage 2) / MEPS V .**

2. Input :

2.1 Voltage	Universal 100~240Vac, single phase
2.2 Frequency	47 ~ 63 Hz
2.3 Current	0.19A Max.
2.4 Inrush Current	60A Max. / 240Vac (Cold start At 25 °C , full load)
2.5 Efficiency	Eff (av) \geq 74.89 % (At 115 Vac & 230 Vac)
2.6 Power Consumption	Pi \leq 0.3 W (At 115 Vac & 230Vac & No Load)

$$\text{※Eff}_{(av)} = \frac{E_1 + E_2 + E_3 + E_4}{4}$$

E1=efficiency with 25% rated load ; E2= efficiency with 50% rated load
E3=efficiency with 75% rated load ; E4= efficiency with 100% rated load

3. Output :

3.1 DC Output	Voltage	+15.00V \pm 5%
	Current	0.5A Max.
	Regulation	14.25Vmin. ~ 15.0Vtyp. ~ 15.75Vmax.
	Ripple & Noise	150 mVpp Max.
	Total Power	7.5W Max.

Remark : For ripple & noise measurement, use a 20MHz bandwidth frequency oscilloscope, and add a 0.1 μ F multilayer Cap. and a Low ESR Electrolytic Cap. (10 μ F) at output connector terminals. (At nominal line voltage, full load)

4. Protection :

4.1 Over Voltage Protection (OVP)	V out *180%(Max)
4.2 Short Circuit Protection (SCP)	Automatic recovery after short-circuit fault being removed
4.3 Over Current Protection(OCP)	1.3 (Max)(Auto Recovery)

Remark : When Short Circuit Protection is activated, the power supply will shutdown automatically. Once the abnormal condition resulting in the failure being removed, the power supply will restart accordingly. When over voltage Protection is working, the power supply will shutdown .

5. Safety 、 EMI and EMC Requirement :

5.1 Safety Requirement

- a. Safety : CE / CB
- b. Dielectric Strength : Cut off current 10mA

(1)	Primary to Secondary	3000Vac for 1 Minute
-----	----------------------	----------------------

c. Insulation Resistance :

(1)	Primary to Secondary	10 M ohm for 500Vdc
-----	----------------------	---------------------

5.2 EMI Requirement : CE /EMC Class B ; Conduction & Radiation Meet.

5.3 Leakage Current : Less than 0.25mA

6. Operation and Environment Performance :

6.1 Temperature Range

Operating	+ 0°C ~ + 40°C
Storage	- 20 °C ~ + 60 °C

6.2 Humidity Range(Non-condensing)

Operating	20% ~ 80% RH
Storage	10% ~ 90% RH

6.3 Cooling : By natural air.

7. M.T.B.F. : 50,000 hours min. (at 25°C, by MIL-HDBK-217F)

8.Mechanical :

8.1 Weight : 100 g Typical

8.2 Cable Type : Black UL2468 22AWG
(Wire + Plug)

Plug : $\phi 5.5 * \phi 2.1 * 12\text{mm}$
(Tuning Fork & Cannelure)

Cable Drawing No. : ADT-1173

8.3 Cable Length : 1800mm

8.4 Case Dimension : 52mm(L)*50mm(W)*75.2mm(H)

8.5 Material Flammability : UL 94V-0

8.6 External Apperance : As drawing below (Scale \rightarrow mm)

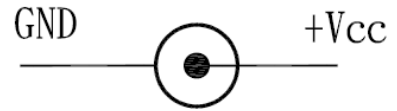

Output Cable Plug Pin Assignment

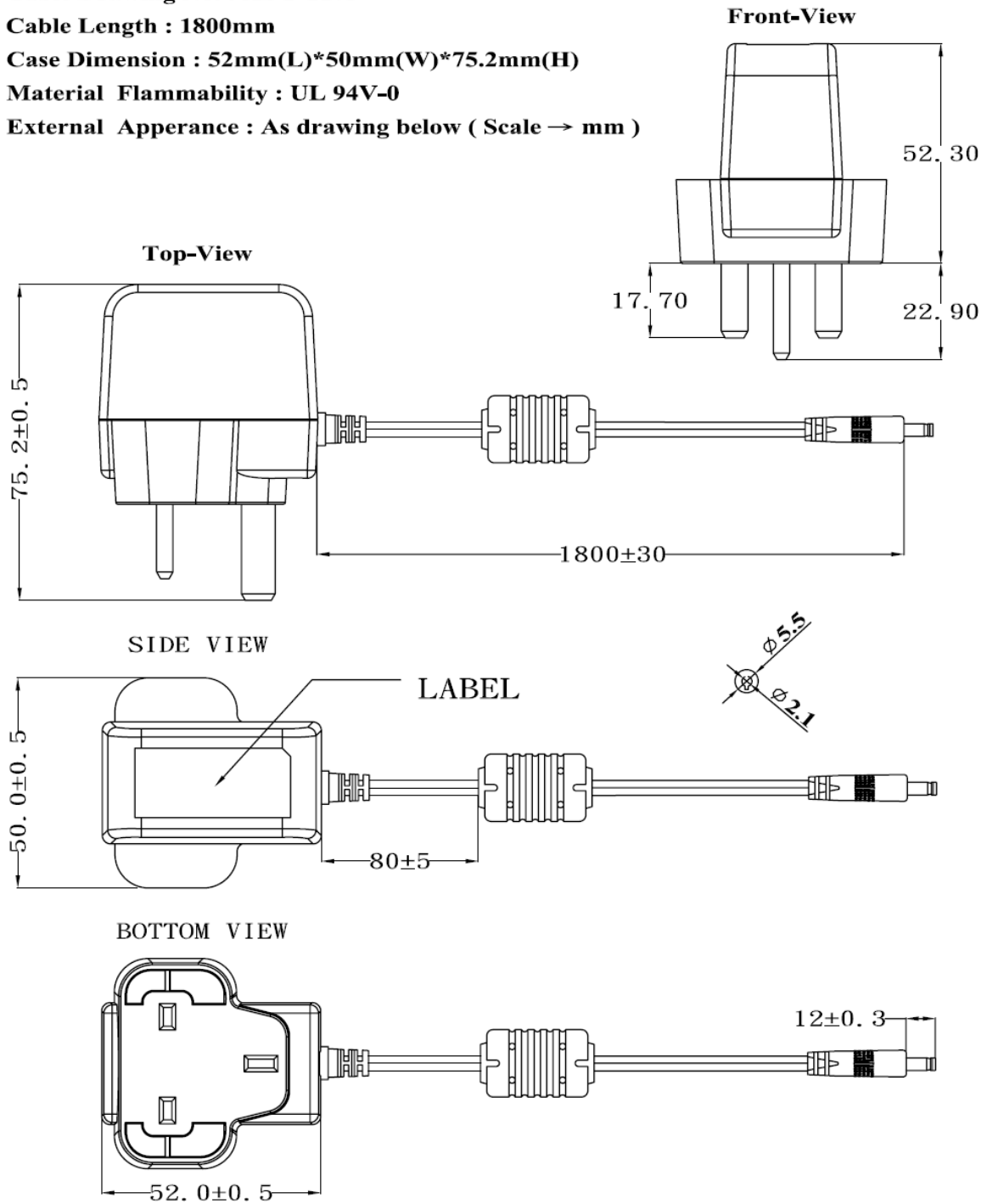

8.7 Spec. Label Materials : Metalized Polyester Label (Silver Gloss)
 Color : Black Background with Silver Printing
 Label Dimension : 16.0mm(L)*36.5mm(W)+/-0.1mm
 Label Thickness : #75

100%



300%



"XXX"

Label supplier's code.
 It is accurate that the number
 of words depends on the real
 finished product.

ID NO."X"

Manufacturer's code.
 It is accurate that the number
 of words depends on the real
 finished product.

Label Part No. :9443022180
REV:A

8.8 White Box Label Materials : Art paper + Gloss
Color : White Background with Black Printing
Label Dimension : 46.5mm(L)*12.5mm(W)+/-0.1mm
Label Thickness : 0.1mm

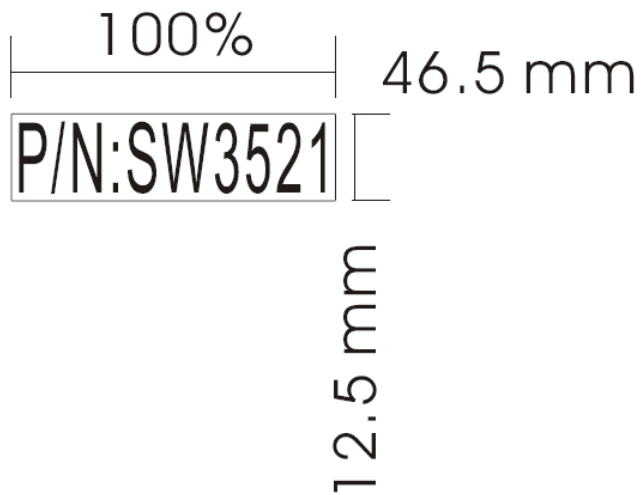

Label Part No. :9443010591
REV:B

A. Line Regulation Test

Test Result :

Test condition	Spec.	Reading 1	Reading 2	Reading 3
90Vac / 50 % Load	14.25 V ~ 15.75 V	15.117 V	15.107 V	15.117 V
115Vac / 50 % Load	14.25 V ~ 15.75 V	15.117 V	15.107 V	15.117 V
132Vac / 50 % Load	14.25 V ~ 15.75 V	15.117 V	15.107 V	15.117 V
180Vac / 50 % Load	14.25 V ~ 15.75 V	15.106 V	15.107 V	15.106 V
230Vac / 50 % Load	14.25 V ~ 15.75 V	15.106 V	15.107 V	15.106 V
264Vac / 50 % Load	14.25 V ~ 15.75 V	15.106 V	15.107 V	15.106 V

B. Efficiency Test

Test Result :

Test condition	Spec.	Reading 1	Reading 2	Reading 3
115Vac	74.89 % Min.	79.37 %	78.59 %	79.37 %
230Vac	74.89 % Min.	76.49 %	75.33 %	76.49 %

$$\text{Eff}_{(av)} = \frac{E_1 + E_2 + E_3 + E_4}{4}$$

E1=efficiency with 25% rated load ; E2= efficiency with 50% rated load
E3=efficiency with 75% rated load ; E4= efficiency with 100% rated load

C. Load Regulation Test

Test Result :

Test condition	Spec.	Reading 1	Reading 2	Reading 3
115Vac / 0 % Load	14.25 V ~ 15.75 V	15.176 V	15.187 V	15.176 V
115Vac / 50 % Load	14.25 V ~ 15.75 V	15.117 V	15.107 V	15.117 V
115Vac / 100 % Load	14.25 V ~ 15.75 V	15.062 V	15.035 V	15.062 V
230Vac / 0 % Load	14.25 V ~ 15.75 V	15.166 V	15.181 V	15.166 V
230Vac / 50 % Load	14.25 V ~ 15.75 V	15.106 V	15.107 V	15.106 V
230Vac / 100 % Load	14.25 V ~ 15.75 V	15.050 V	15.039 V	15.050 V

D. Ripple & Noise Test

Test Result :

Test condition	Spec.	Reading 1	Reading 2	Reading 3
115Vac / 100 % Load	150mVpp Max.	18.6 mVpp	19.7 mVpp	18.6 mVpp
230Vac / 100 % Load	150mVpp Max.	21.6 mVpp	22.1 mVpp	21.6 mVpp

E. Inrush Current

Test Result :

Test condition	Spec.	Reading 1	Reading 2	Reading 3
115Vac / 100 % Load	30A Max	15.0A	15.3A	17.1A
230Vac / 100 % Load	60A Max	29.3A	30.3A	33.8A

F. Over Current Protection

Test Result :

Test condition	Spec.	Reading 1	Reading 2	Reading 3
115Vac / 100 % Load	1.3A (Max)	0.78 A	0.76 A	0.73 A
230Vac / 100 % Load	1.3A (Max)	0.90 A	0.87 A	0.90 A

G. Short Circuit Protection

Test Result :

Test condition	Spec.	Reading 1	Reading 2	Reading 3
115Vac / 100 % Load	Auto Recovery	OK	OK	OK
230Vac / 100 % Load	Auto Recovery	OK	OK	OK

H. Input Power Consumption(No Load)

Test Result :

Test condition	Spec.	Reading 1	Reading 2	Reading 3
115Vac / 0 % Load	≤ 0.3 W	0.11W	0.11W	0.11W
230Vac / 0 % Load	≤ 0.3 W	0.13W	0.14W	0.13W

Efficiency Test Report

- A. **Model Number** : STD-15005X (X=B,C,E,K,U)(15.0V /0.5A /7.5W)
- B. **DC Power Cord** : UL2468 , 22AWG , 1.8M
- C. **Average Efficiency** :
- Energy Star V $(0.0626 * \ln(\text{Nameplate OutputW}) + 0.622) = 74.81 \%$ Min.
- Erp (Stage 2) $(0.063 * \ln(\text{Nameplate OutputW}) + 0.622) = 74.89 \%$ Min.
- MEPS V $(0.0626 * \ln(\text{Nameplate OutputW}) + 0.622) = 74.81 \%$ Min.
- D. **NO Load Power Consumption** :
- Energy Star V 0.3W max.
- Erp (Stage 2) 0.3W max.
- MEPS V 0.3W max.
- E. **Testing Dequpment** :
1. AC Power Source : " Zentech " 2700M-10
2. Electronic Load : " PRODIGIT " 3311C
3. Power Meter : " YOKOGAWA " WT210
4. Digital Meter : " FLUKE " 45
- F. **AC Input Voltage** : 115Vac/60Hz

Load Conditions Reported Quantity	100%* I ₀	75%* I ₀	50%* I ₀	25%* I ₀	0%* I ₀
Rms Output Current(mA)	500mA	375mA	250mA	125mA	0mA
Rms Output Voltage(V)	15.062V	15.089V	15.117V	15.147V	15.176V
Active Output Power(W)	7.53W	5.66W	3.78W	1.89W	0.00W
Rms Input Voltage(V)	115V	115V	115V	115V	115V
Rms Input Current(A)	0.142A	0.110A	0.081A	0.049A	0.005A
Rms Input Power(W)	9.32W	6.90W	4.70W	2.55W	0.11W
Voltage T.H.D.(%)	0.12	0.11	0.11	0.11	0.11
True Power Factor	0.571	0.543	0.505	0.448	0.177
Power Consumed by UUT(W)	1.79W	1.24W	0.92W	0.66W	0.11W
Efficiency	80.80%	82.01%	80.41%	74.25%	*
Average Efficiency	79.37%				*

- G. **AC Input Voltage** : 230Vac/50Hz

Load Conditions Reported Quantity	100%* I ₀	75%* I ₀	50%* I ₀	25%* I ₀	0%* I ₀
Rms Output Current(mA)	500mA	375mA	250mA	125mA	0mA
Rms Output Voltage(V)	15.050V	15.078V	15.106V	15.137V	15.166V
Active Output Power(W)	7.53W	5.65W	3.78W	1.89W	0.00W
Rms Input Voltage(V)	230V	230V	230V	230V	230V
Rms Input Current(A)	0.092A	0.073A	0.055A	0.033A	0.007A
Rms Input Power(W)	9.39W	7.02W	4.97W	2.73W	0.13W
Voltage T.H.D.(%)	0.10	0.10	0.09	0.09	0.09
True Power Factor	0.443	0.418	0.388	0.361	0.078
Power Consumed by UUT(W)	1.87W	1.37W	1.19W	0.84W	0.13W
Efficiency	80.14%	80.54%	75.99%	69.31%	*
Average Efficiency	76.49%				*

Tester : Chihwei

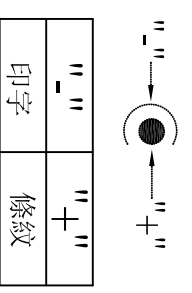
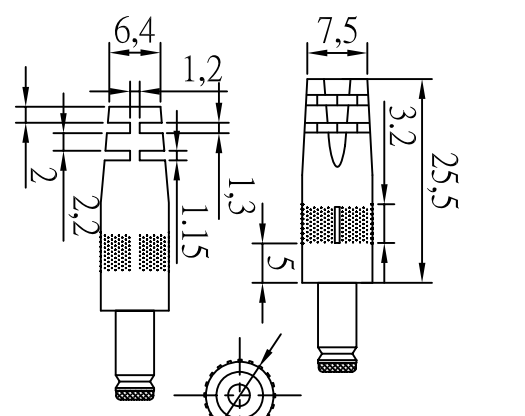
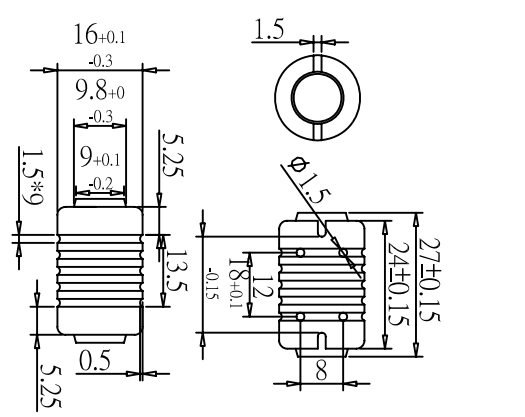
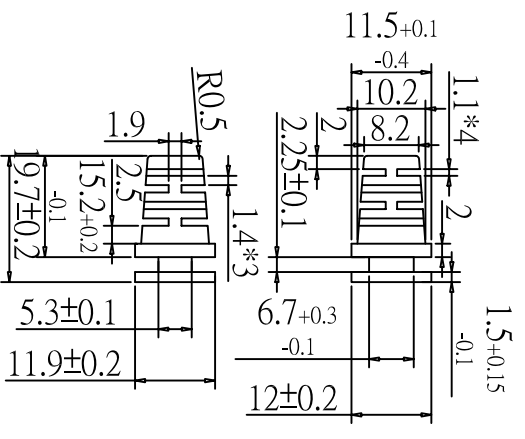
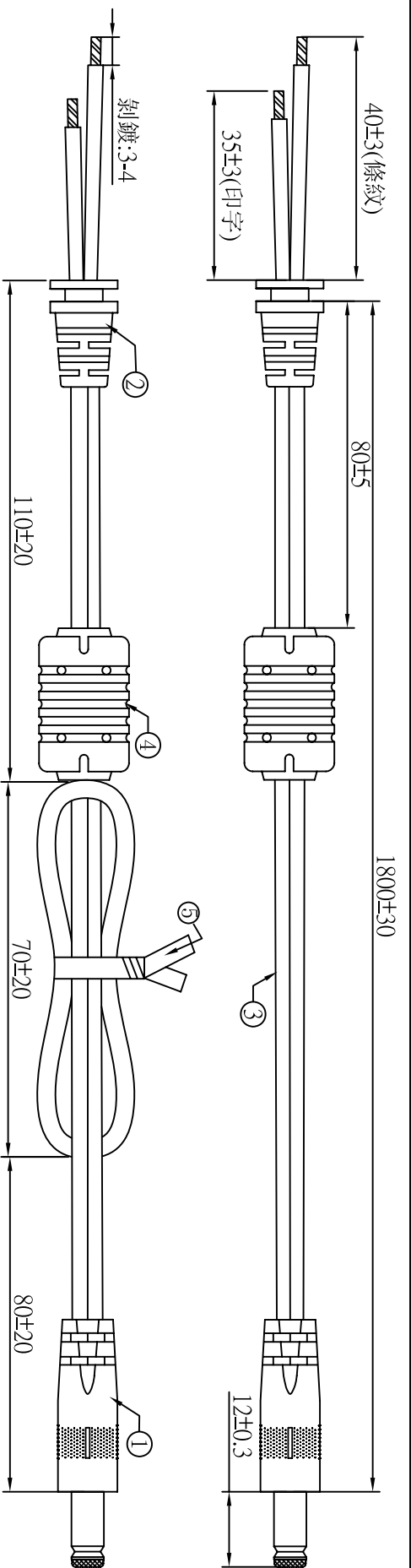

注意:此圖面所需材料符合"ROHS"標準

- ① 5.5*2.1*23音叉車溝黑色半邊,外模P-146號模(二次成型),用料外PVC60P黑色(YY-PV-00009)
- ② SR-380號模,用料PVC60P黑色(YY-PV-00009),吊重:1米/20磅/60秒
- ③ UL 2468 22AWG(0.16*17)*2C BK OD:1.8*3.6(YY-DC-00025) 裁線長度:1860+10/-0
- ④ 鐵芯:12*20*5.6,外模P-136號模(二次成型),用料外PVC40P黑色(YY-PV-00009)
- ⑤ PE有鐵芯紫帶12CM,黑色(YY-ES-00001)
- ⑥ 絕緣阻抗:20Ω,導通阻抗:1.5Ωmax
- ⑦ 單位:MM

版次	變更內容	圖號	日期
02	變更繞線尺寸	ADT-1173	2010/08/05

料號	R44M1C1801K		
客戶	阿達特	制圖	吳遠松
版次	02	初審	
頁數	01	審核	
泰岳電子有限公司			
批準			

SHOW	REV	DESCRIPTION	DATE	APPROVED
△	A	初版制作	Jun./25/2009	

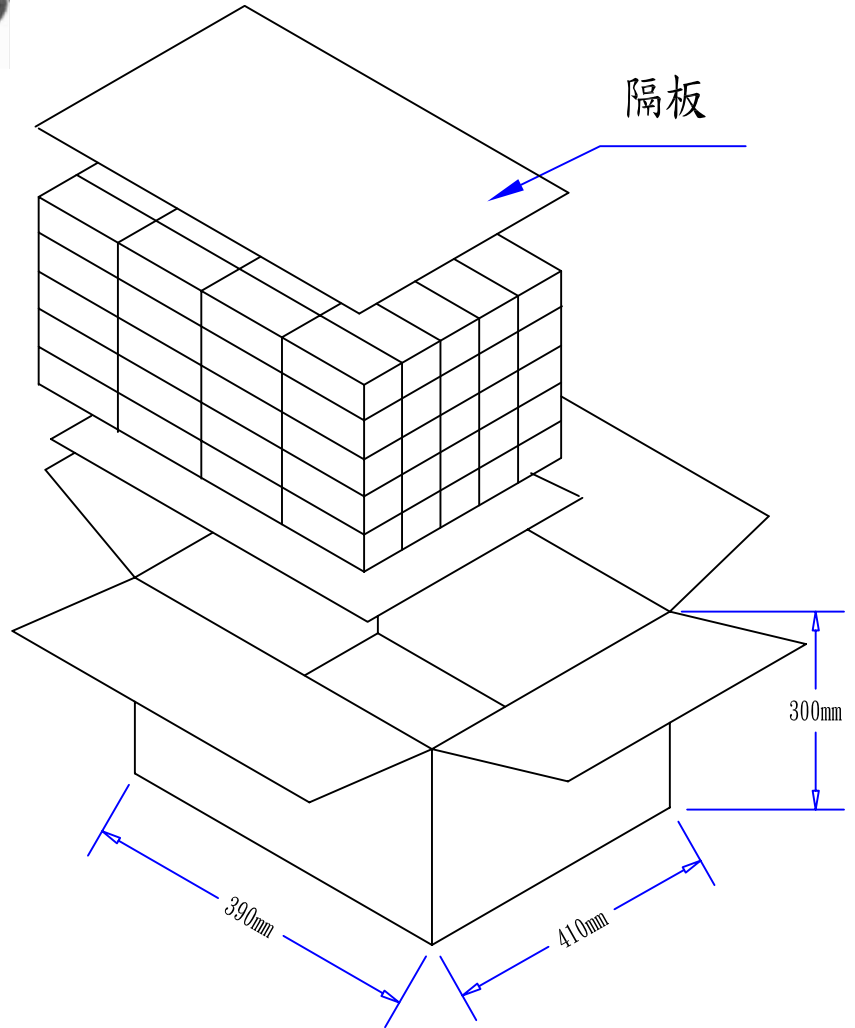
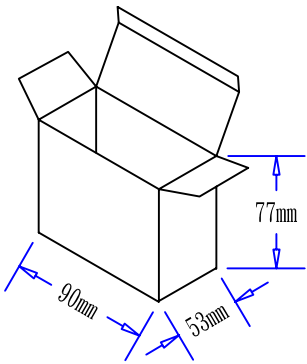
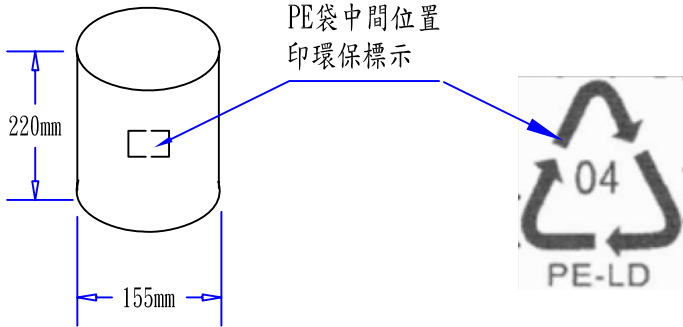

零件料號

9550001501

1. 隔板:400*380*6mm B=B 2/100

2. 數量:20*5=100PCS

9520000202

3. 外箱:L*W*H=410*390*300mm K=K 1/100

9510001302

4. 紙盒:L*W*H=90*53*77mm 白盒 350P+CE(即C9紙加裱350磅白板紙)

9540003001

5. 環保PE袋:220*155*0.09mm 無色透明,長邊中間位置印環保標示,短邊單端開口

6. 成品裝入PE袋后,用小膠紙封口

7. 外箱,紙盒標注為外徑尺寸

阿達特科技股份有限公司

DRAWING NO. PIS5W000002		APPROVAL 1 BY	
UNIT mm	MODEL NO. 5W.10W(美規)	APPROVAL 2 BY	
	FILE NO. PACKAGE_Y_159	CHECKED BY(ENGINEER)	廖志偉(Chihwei) DATE: 2009/06/25
SCALE	REV. A	SHEET 1/1	DRAWN BY sun DATE: 2009/06/25