

MR45V256A

Preliminary

256k(32,768-Word × 8-Bit) FeRAM (Ferroelectric Random Access Memory) SPI

GENERAL DESCRIPTION

The MR45V256A is a nonvolatile 32,768-word x 8-bit ferroelectric random access memory (FeRAM) developed in the ferroelectric process and silicon-gate CMOS technology. The MR45V256A is accessed using Serial Peripheral Interface. Unlike SRAMs, this device, whose cells are nonvolatile, eliminates battery backup required to hold data. This device has no mechanisms of erasing and programming memory cells and blocks, such as those used for various EEPROMs. Therefore, the write cycle time can be equal to the read cycle time and the power consumption during a write can be reduced significantly.

The MR45V256A can be used in various applications, because the device is guaranteed for the write/read tolerance of 10^{12} cycles per bit and the rewrite count can be extended significantly.

FEATURES

- 32,768-word × 8-bit configuration (Serial Peripheral Interface : SPI)
- A single 3.3 V ± 0.3 V power supply
- Operating frequency: 15MHz
- Read/write tolerance: 10^{12} cycles/bit
- Data retention: 10 years
- Guaranteed operating temperature range: -40 to 85°C (Extended temperature version)
- Package options:
 - 8-pin plastic SOP (P-SOP8-200-1.27-T2K)

PIN CONFIGURATION

8-pin plastic SOP

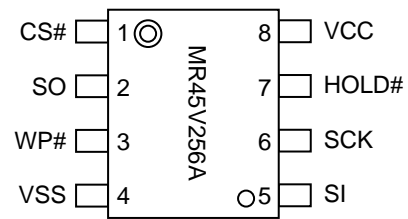
**Note:**

Signal names that end with # indicate that the signals are negative-true logic.

PIN DESCRIPTIONS

Pin Name	Description
CS#	Chip Select (input, negative logic) Latches an address by low input, activates the FeRAM, and enables a read or write operation.
WP#	Write Protect(input , negative logic) Write Protect pin controls write-operation to the status-register(BP0,BP1). This pin should be fixed low or high in write-operations.
HOLD#	HOLD(input , negative logic) Hold pin is used when the serial-communication suspended without disable the chip select. When HOLD# is low ,the serial-output is in High-Z status and serial-input/serial-clock are "Don' t Care" . CS# should be low in hold operation.
SCK	Serial Clock Serial Clock is the clock input pin for setting for serial data timing. Inputs are latched on the rising edge and output occur on the falling edge.
SI	Serial input SI pins are serial input pins for Operation-code , addresses ,and data-inputs .
SO	Serial output SO pins are serial output pins.
V _{CC} , V _{SS}	Power supply Apply the specified voltage to V _{CC} . Connect V _{SS} to ground.

SPI mode0 (CPOL=0, CPHA=0)

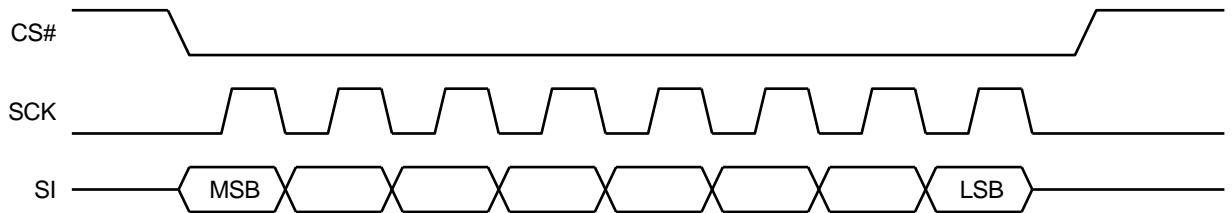

SPI mode3 (CPOL=1, CPHA=1)

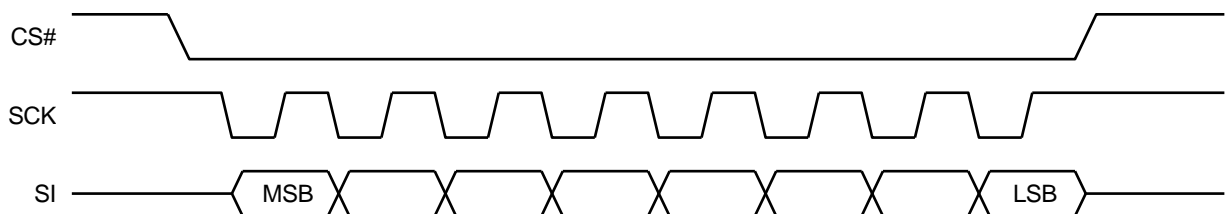

Status Register

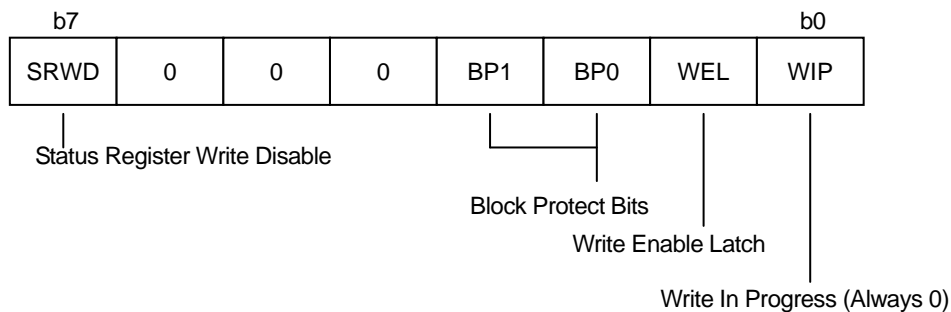

Name	Function
WIP	Fixed to 0.
WEL	Write Enable Latch. This indicates internal WEL condition.
BP0,BP1	Block Protect :These bits can be changed protect area . This is the software protect.
SRWD	Status Register Write Disable (SRWD) : SRWD controls the effect of the hardware WP# pin. This device will be in hardware-protect by combination of SRWD and WP#.
0	Fixed to 0.

Status Register data are volatile.

Set Status Register data by WRSR(Write status register) command, after power on.

Operation-Code

Operation codes are listed in the table below. If the device receives invalid operation code, the device will be deselected.

Instruction	Description	Instruction format
WREN	Write Enable	0000 0110
WRDI	Write Disable	0000 0100
RDSR	Read Status Register	0000 0101
WRSR	Write Status Register	0000 0001
READ	Read from Memory Array	0000 0011
WRITE	Write to Memory Array	0000 0010

Commands

WREN(Write Enable)

It is necessary to set Write Enable Latch (WEL) bit before write-operation (WRITE and WRSR).

WREN command sets WEL bit.

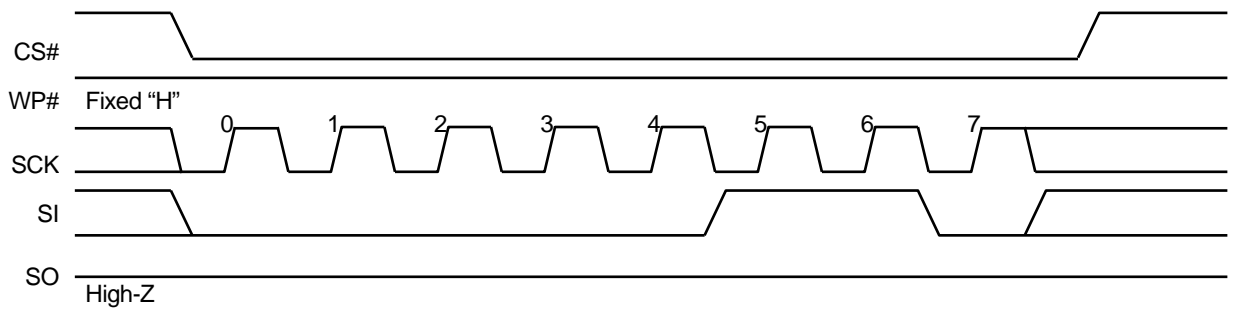

WRDI(Write Disable)

WRDI command resets WEL bit.

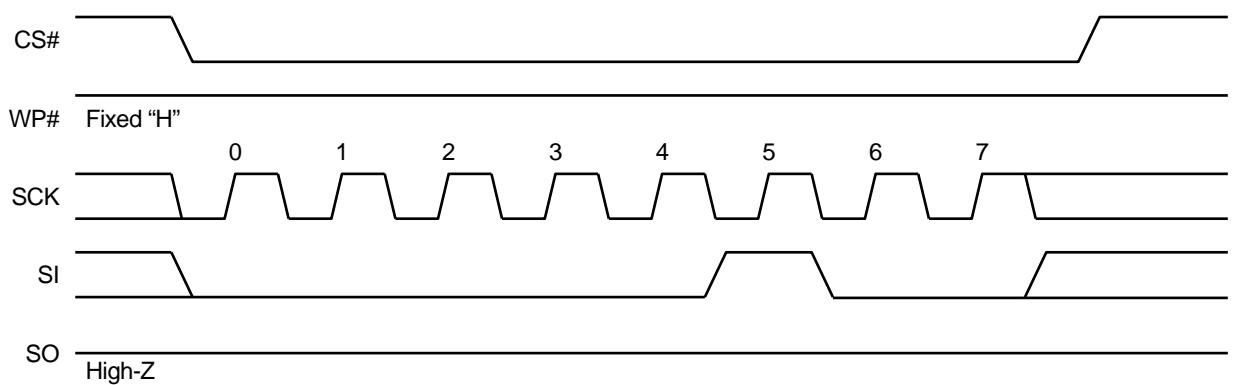

RDSR(READ Status Register)

The RDSR command allows to read data of status register.

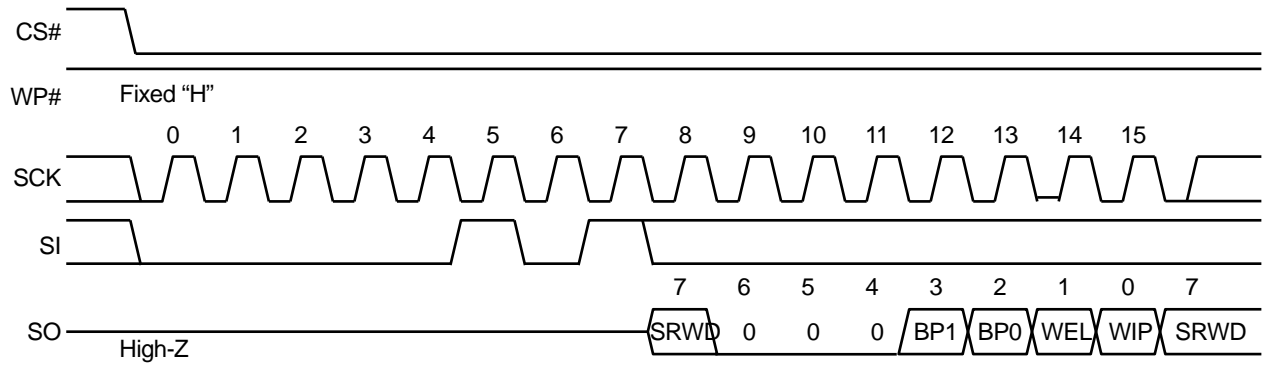

WRSR(WRITE Status Register)

WRSR command allows to write data to status register(SRWD,BP0,BP1). It is necessary to set Write Enable Latch (WEL) bit by WREN command before executing WRSR.

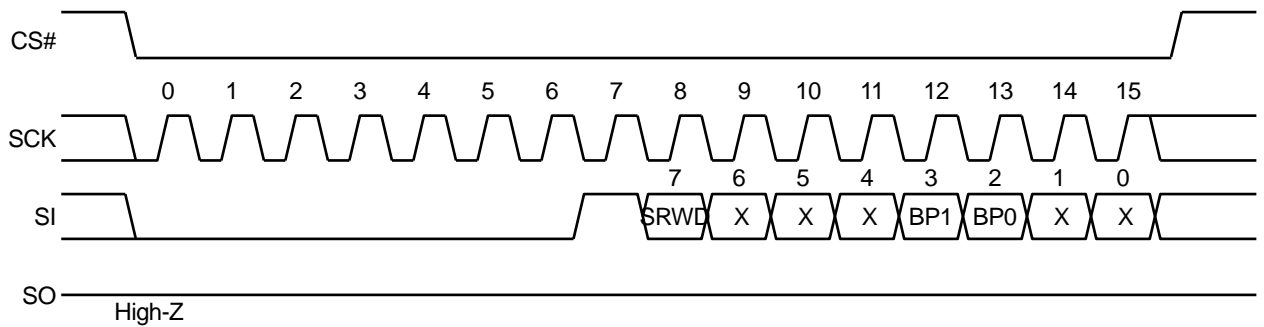

Note:

WP# = Fix "H"

READ(Read from Memory Array)

READ command can be valid when CS# goes "L", then the op-code and 16bit-addresses are inputted to serial input "SI". The inputted addresses are loaded to internal register, then the data from corresponded address is output at serial-output "SO". If CS# will keep "L", the internal address will be increased automatically after 8 clocks and will output the data from new-address. When it reaches the most significant address, the address counter rolls over to starting address, and reading cycle can be continued infinitely.

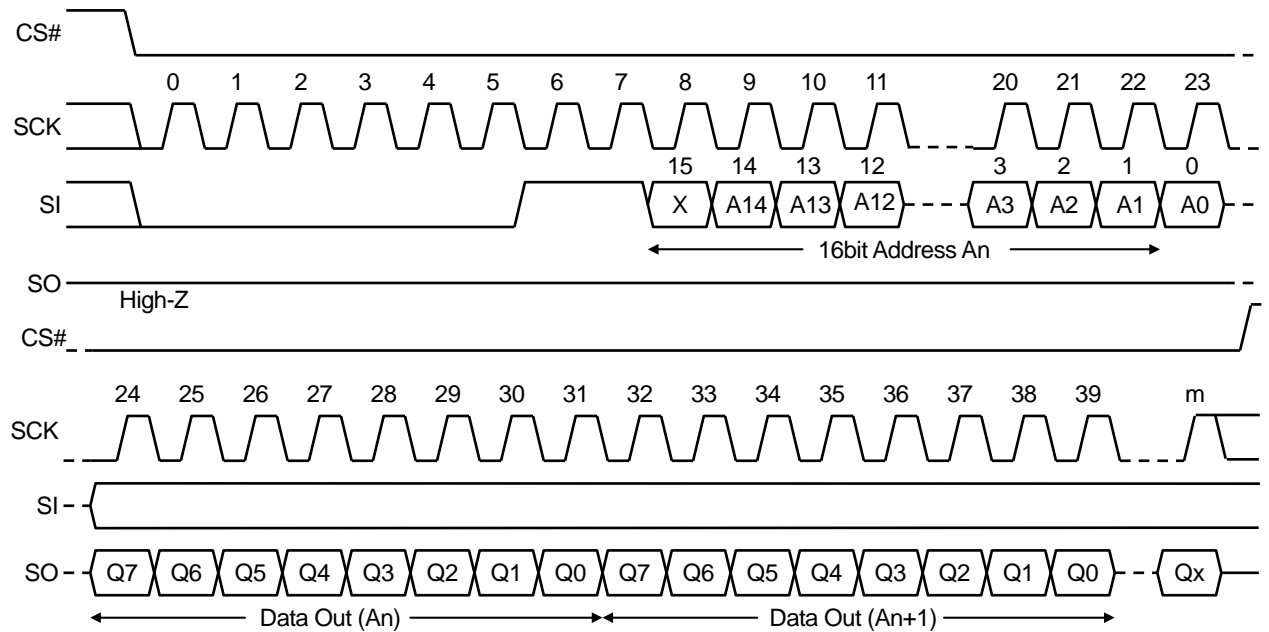

Note : WP# = fixed "H"

WRITE(Write to Memory Array)

Write command can be valid when CS# goes “L”, then the op-code and 16bit-addresses are inputted to serial input “SI”. Writing is terminated when CS# goes high after data-input. If CS# will keep “L”, the internal address will be increased automatically. When it reaches the most significant address, the address counter rolls over to starting address 0000h, and writing cycle (overwriting) can be continued infinitely.

WRITE(1Byte)

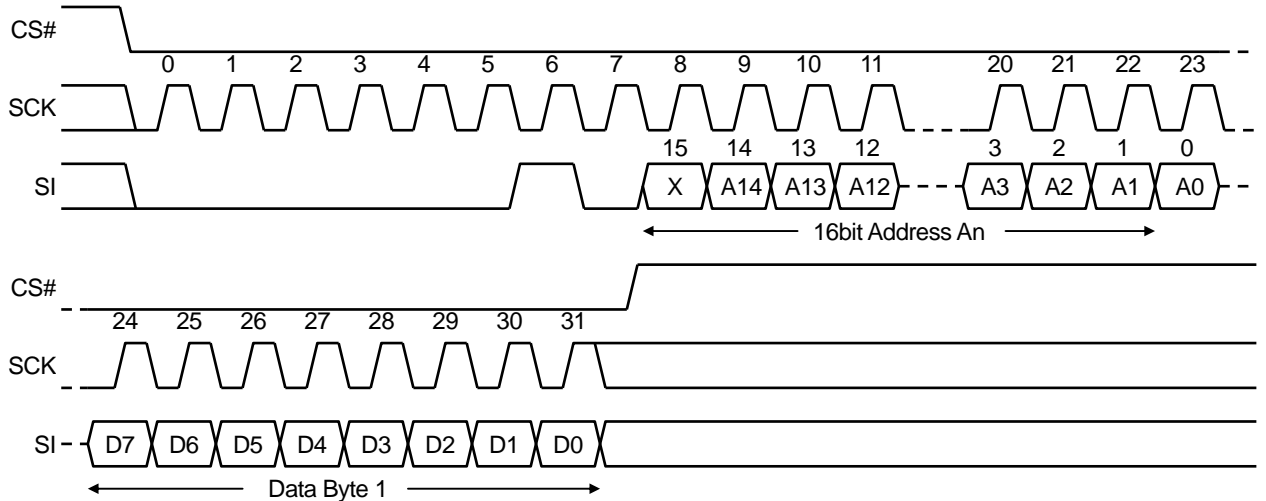

Note : WP# = Fixed "H" , SO=High-Z

WRITE(Page)

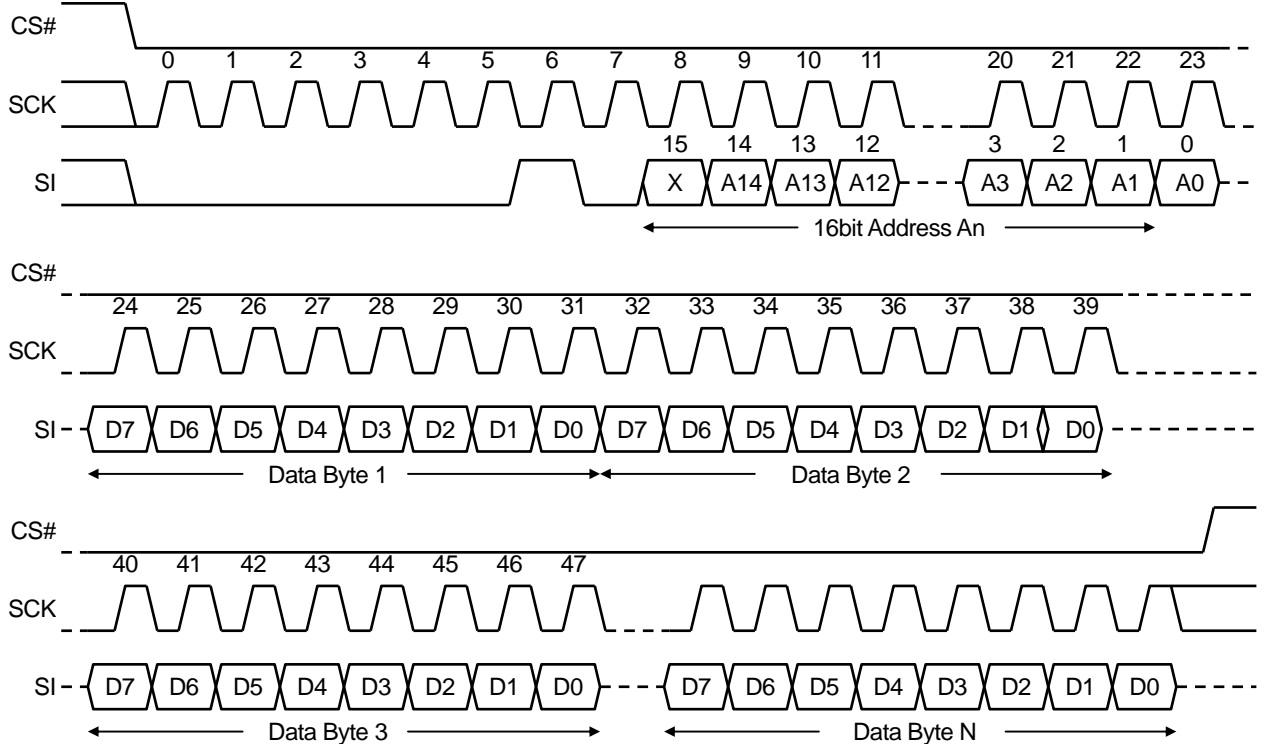

Note : WP# = Fixed "H" , SO=High-Z

Write Protection

Writing protection block is shown as follows:

Protect Block size

Block Protect BIT		Protected Block	Protected Address Area
BP1	BP0		
0	0	None	None
0	1	Upper 1/4 block	6000h – 7FFFh
1	0	Upper 1/2 block	4000h – 7FFFh
1	1	All	0000h – 7FFFh

Writing Protect

WP#	SRWD	mode	Writing protection status in status register	Protection status in memory	
				Protected blocks	Unprotected blocks
1	0	Software protection (SPM)	Status register is unprotected when WEL-bit is set by WREN command. BP0 and BP1 are unprotected.	Protected	Unprotected
0	0				
1	1				
0	1	Hardware protection (HPM)	Status register is protected. BP0 and BP1 are protected.	Protected	Unprotected

HOLD

Hold status is used for suspending serial communication without disable the chip. SO becomes "High-Z" and SI is "Don't care" during the hold status. It is necessary to keep CS#=L in hold status.

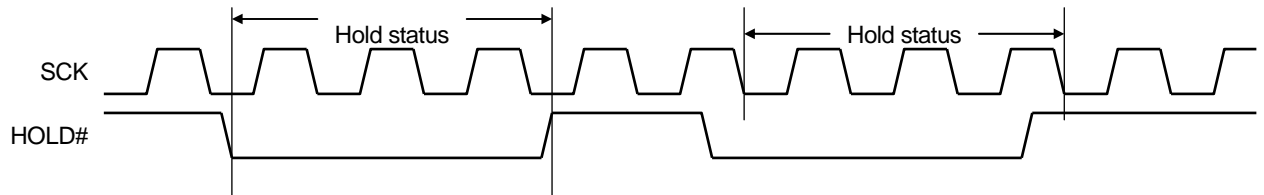

ELECTRICAL CHARACTERISTICS**Absolute Maximum Ratings**

The application of stress (voltage, current, or temperature) that exceeds the absolute maximum rating may damage the device. Therefore, do not allow actual characteristics to exceed any one parameter ratings

Pin voltages

Parameter	Symbol	Rating		Unit
		Min.	Max.	
Pin Voltage (Input Signal)	V_{IN}	-0.5	$V_{CC} + 0.5$	V
Pin Voltage (Input/Output Voltage)	V_{INQ}, V_{OUTQ}	-0.5	$V_{CC} + 0.5$	V
Power Supply Voltage	V_{CC}	-0.5	4.0	V

Temperature Range

Parameter	Symbol	Rating		Unit	Note
		Min.	Max.		
Storage Temperature (Extended Temperature Version)	Tstg	-55	125	°C	
Operating Temperature (Extended Temperature Version)	Topr	-40	85	°C	

Others

Parameter	Symbol	Rating	Unit
Power Dissipation	P_D	1,000mW	
Allowable Input Current	I_{IN}	+/- 20mA	Ta=25°C
Allowable Output Current	I_{OUT}	+/- 20mA	Ta=25°C

Recommended Operating Conditions**Power Supply Voltage**

[V]

Parameter	Symbol	Min.	Typ.	Max.	Note
Power Supply Voltage	V_{CC}	3.0	3.3	3.6	
Ground Voltage	V_{SS}	0	0	0	

DC Input Voltage

[V]

Parameter	Symbol	Min.	Max.	Note
Input High Voltage	V_{IH}	$V_{CC} \times 0.8$	$V_{CC} + 0.3$	
Input Low Voltage	V_{IL}	-0.3	$V_{CC} \times 0.2$	

Overshoot/Undershoot tolerance

Parameter	Symbol	Pulse Width	Peak
"H" input	V_{IH} OVERSHOOT	$\leq 20\text{ns}$	$V_{CC} + 1.0\text{V}$
"L" input	V_{IL} UNDERSHOOT	$\leq 20\text{ns}$	-1.0V

DC Characteristics**DC Input/Output Characteristics**

Parameter	Symbol	Condition	Min.	Max.	Unit	Note
Output High Voltage	V_{OH}	$I_{OH} = -2\text{mA}$	$V_{CC} \times 0.85$	—	V	
Output Low Voltage	V_{OL}	$I_{OL} = 2\text{mA}$	—	$V_{CC} \times 0.15$	V	
Input Leakage Current	I_{LI}	—	-10	10	μA	
Output Leakage Current	I_{LO}	—	-10	10	μA	

Power Supply Current $V_{CC} = \text{Max. to Min.}, T_a = \text{Topr}$

Parameter	Symbol	Condition	Max.	Unit	Note
Power Supply Current (Standby)	I_{CCS}	$V_{IN} = 0.2\text{V}$ or $V_{CC} - 0.2\text{V}$	400	μA	
Power Supply Current (Operating)	I_{CCA}	$V_{IN} = 0.2\text{V}$ or $V_{CC} - 0.2\text{V}$, $SCK = 15\text{MHz}$, $I_{OUT} = 0\text{mA}$	10	mA	

MR45V256A**AC Characteristics (Read Cycle)**V_{CC}=Max. to Min., Ta=Topr.

Parameter	Symbol	MR45V256A		Unit	Note
		Min.	Max.		
Clock frequency	f _C	D.C.	15	MHz	
CS# Active setup time	t _{SLCH}	10	—	ns	
CS# In-active setup-time	t _{SHCH}	10	—	ns	
CS# De-select time	t _{SHSL}	10	—	ns	
CS# Active hold time	t _{CHSH}	10	—	ns	
CS# In-active hold-time	t _{CHSL}	10	—	ns	
SCK High time	t _{CH}	30	—	ns	1
SCK Low time	t _{CL}	30	—	ns	1
SCK Rise time	t _{CLCH}	—	1	ns	2
SCK Fall time	t _{CHCL}	—	1	ns	2
Data Setup time	t _{DVCH}	5	—	ns	
Data Hold time	t _{CHDX}	5	—	ns	
SCK Low Hold time after HOLD# inactive	t _{HHCH}	10	—	ns	
SCK Low Hold time after HOLD# active	t _{HLCH}	10	—	ns	
SCK High Setup time before HOLD# active	t _{CHHL}	10	—	ns	
SCK High Setup time before HOLD# inactive	t _{CHHH}	10	—	ns	
Output disable time	t _{SHQZ}	—	20	ns	2
SCK Low to Output Valid time	t _{CLQV}	—	35	ns	
Output Hold time	t _{CLQX}	0	—	ns	
Output Rise time	t _{QLQH}	—	50	ns	2
Output Fall time	t _{QHQL}	—	50	ns	2
HOLD# High to Output Low impedance time	t _{HHQX}	—	20	ns	2
HOLD# High to Output High impedance time	t _{HLQZ}	—	20	ns	2

Note: 1. t_{CH}+t_{CL} ≥ 1/f_C
2. sample value

Timing Diagrams

Serial Input Timing

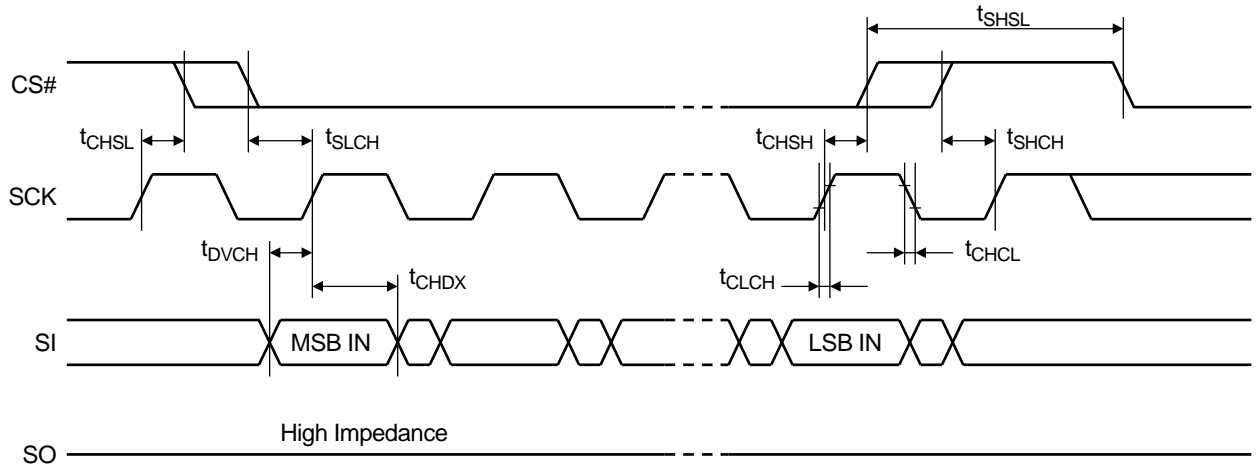

Hold Timing

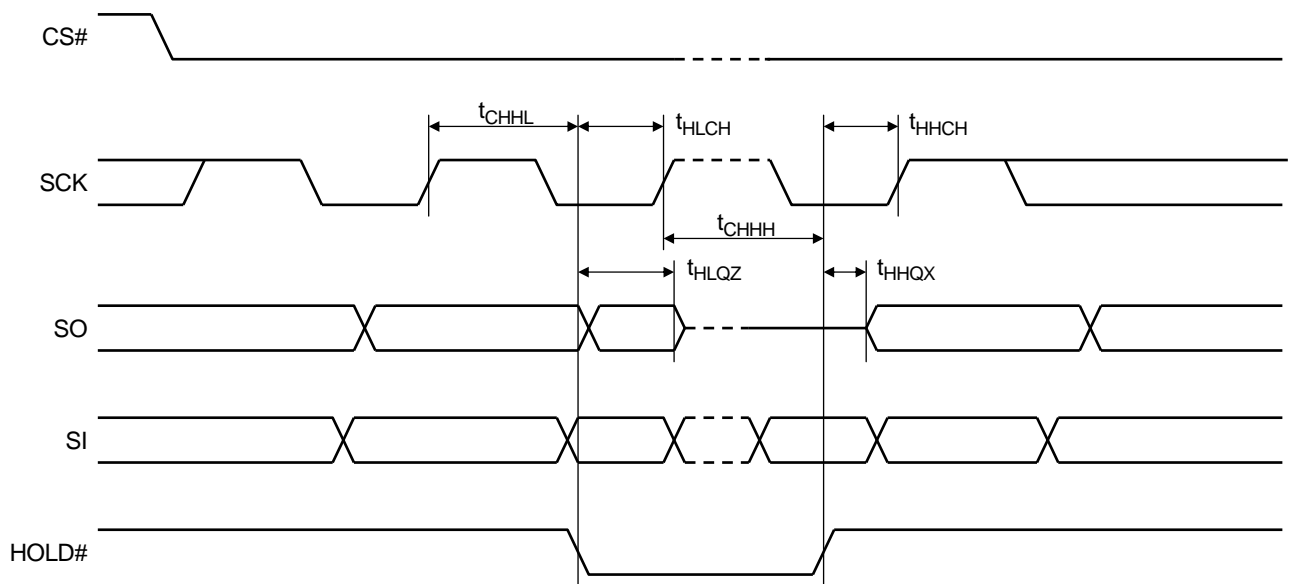

Output Timing

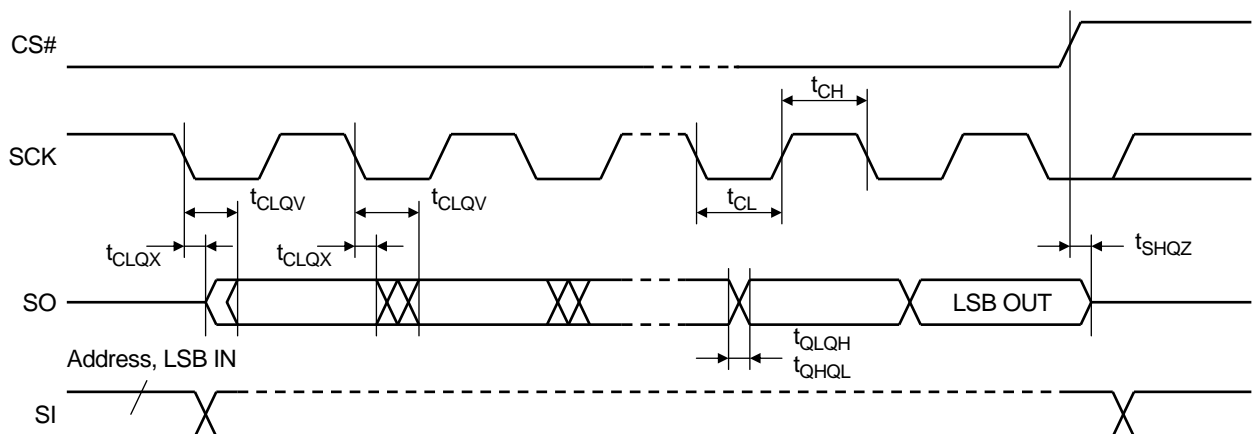

•Power-On and Power-Off Characteristics

(Under recommended operating conditions)

Parameter	Symbol	Min.	Max.	Unit	Note
Power-On CS# High Hold Time	t_{VHEL}	50	—	μs	1, 2
Power-Off CS# High Hold Time	t_{EHVL}	100	—	ns	1
Power-On Interval Time	t_{VLVH}	1	—	μs	2

Notes:

1. To prevent an erroneous operation, be sure to maintain CS#="H", and set the FeRAM in an inactive state (standby mode) before and after power-on and power-off.
2. Powering on at the intermediate voltage level will cause an erroneous operation; thus, be sure to power up from 0 V.
3. Enter all signals at the same time as power-on or enter all signals after power-on.

•Power-On and Power-Off Sequences

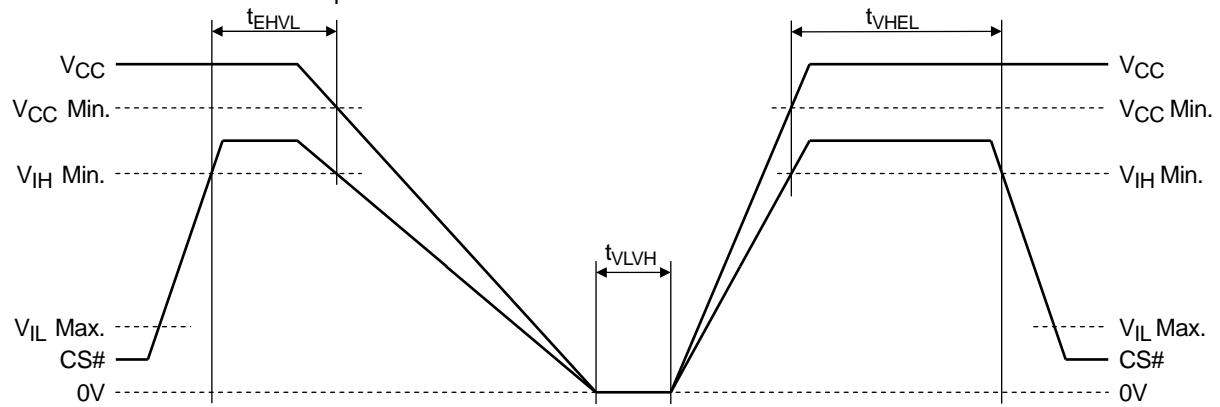

Read/Write Cycles and Data Retention

(Under recommended operating conditions)

Parameter	Min.	Max.	Unit	Note
Read/Write Cycle	10^{12}	—	Cycle	
Data Retention	10	—	Year	

Capacitance

Signal	Symbol	Min.	Max.	Unit	Note
Input Capacitance	C_{IN}	—	10	pF	1
Input/Output Capacitance	C_{OUT}	—	10	pF	1

Note:

Sampling value. Measurement conditions are $V_{IN} = V_{OUT} = GND$, $f = 1\text{MHz}$, and $T_a = 25^\circ\text{C}$

REVISION HISTORY

Document No.	Date	Page		Description
		Previous Edition	Current Edition	
PEDR45V256A-01	Jun. 03, 2010	–	–	Preliminary edition 1 from PJDR45V256A-03
PEDR45V256A-02	Sep. 10, 2010	1,13	1,13	Input Voltage
		7,8,9	7,8,9	fixed CS# waveform
		14	14	I _{CCS} I _{CCA}
PEDR45V256A-03	Mar. 04, 2011	1,12	1,12	temperature version ⇒ Extended version
PEDR45V256A-04	Sep. 05, 2011	4	4	Status Register
		17	17	Input signal state in power-on

NOTICE

1. The information contained herein can change without notice owing to product and/or technical improvements. Before using the product, please make sure that the information being referred to is up-to-date.
2. The outline of action and examples for application circuits described herein have been chosen as an explanation for the standard action and performance of the product. When planning to use the product, please ensure that the external conditions are reflected in the actual circuit, assembly, and program designs.
3. When designing your product, please use our product below the specified maximum ratings and within the specified operating ranges including, but not limited to, operating voltage, power dissipation, and operating temperature.
4. **OKI SEMICONDUCTOR assumes no responsibility or liability whatsoever for any failure or unusual or unexpected operation resulting from misuse, neglect, improper installation, repair, alteration or accident, improper handling, or unusual physical or electrical stress including, but not limited to, exposure to parameters beyond the specified maximum ratings or operation outside the specified operating range.**
5. Neither indemnity against nor license of a third party's industrial and intellectual property right, etc. is granted by us in connection with the use of the product and/or the information and drawings contained herein. No responsibility is assumed by us for any infringement of a third party's right which may result from the use thereof.
6. The products listed in this document are intended for use in general electronics equipment for commercial applications (e.g., office automation, communication equipment, measurement equipment, consumer electronics, etc.). These products are not authorized for use in any system or application that requires special or enhanced quality and reliability characteristics nor in any system or application where the failure of such system or application may result in the loss or damage of property, or death or injury to humans. Such applications include, but are not limited to, traffic and automotive equipment, safety devices, aerospace equipment, nuclear power control, medical equipment, and life-support systems.
7. Certain products in this document may need government approval before they can be exported to particular countries. The purchaser assumes the responsibility of determining the legality of export of these products and will take appropriate and necessary steps at their own expense for these.
8. No part of the contents contained herein may be reprinted or reproduced without our prior permission.

Copyright 2010 OKI SEMICONDUCTOR CO., LTD..

