

10 9 8 7 6 5 4 3 2 1

F

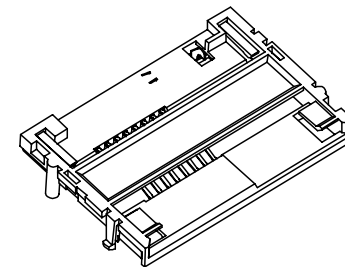
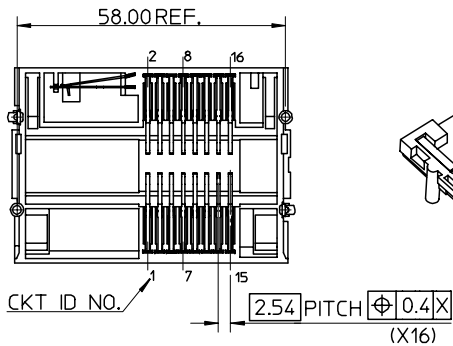
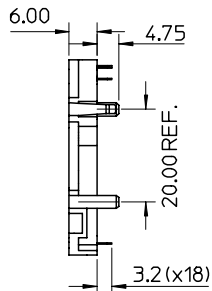
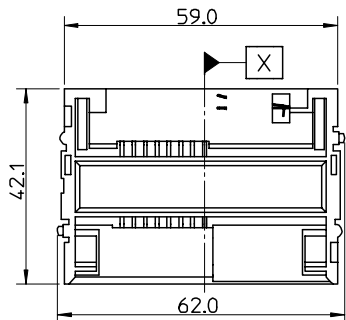

E

D

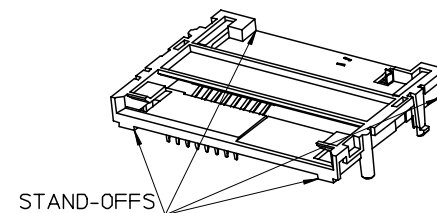
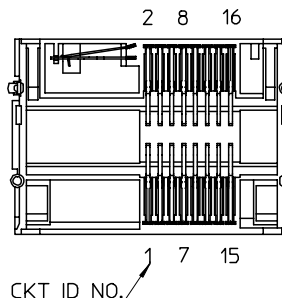
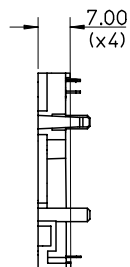
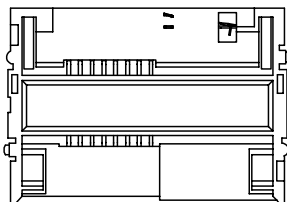

C

B

NOTES:

1. PRODUCT SPECIFICATION PS-91506-001
2. PACKAGING: TRAYS (99025-0062)
3. MATERIAL: HOUSING: GLASS-FILL PBT UL94 V-0.
TERMINAL: COPPER ALLOY.
PLATING: GOLD PLATED.
4. 91506-1001/-1002 USE A ZERO STAND-OFF HOUSING.
91506-1003/-1004 USE A 1mm STAND-OFF HOUSING.
5. CKTS NUMBERED 1 - 8 ON DRAWING ARE USED IN
91506-1001/-1003 & CKTS 1 - 16 SHOWN ABOVE ARE
USED FOR 91506-1002/-1004.

A

| PART NO | CKT SIZE | STAND OFF |
|------------|----------|-----------|
| 91506-1001 | 8 | 0 |
| 91506-1002 | 16 | 0 |
| 91506-1003 | 8 | 1mm |
| 91506-1004 | 16 | 1mm |

| | | | | | | | |
|--|---------------------------------|---|--|--|---------------------------|------------------------|--------------------|
| MODIFIED CROWN POSN EC NO: E2003-0809 DRWN:DBYRNES 2003/02/07 CHKD: 2003/02/07 APPR: MWILHITE 2003/02/12 | QUALITY SYMBOLS ▽ -0 ▽ -0 | GENERAL TOLERANCES (UNLESS SPECIFIED) | | SCALE 1:1 | DESIGN UNITS METRIC | THIRD ANGLE PROJECTION | REVISE ON CAD ONLY |
| | | 4 PLACES ± --- ± --- 3 PLACES ± --- ± --- 2 PLACES ± 0.1 ± --- 1 PLACE ± 0.2 ± --- ANGULAR ± 2 ° | DIMENSION STYLE MM ONLY | TITLE THOLE FRICTION SMARTCARD READER WITH NC SWITCH 8/16CKT | | MOLEX INCORPORATED | |
| | | DRAFT WHERE APPLICABLE MUST REMAIN WITHIN DIMENSIONS | DRAWN BY DMCNAMAR DATE 01/05/17 CHECKED BY ROCONNOR DATE 01/05/17 APPROVED BY MWILHITE DATE 01/05/17 | MATERIAL NO. SEE CHART | DOCUMENT NO. SD-91506-001 | SHEET NO. 1 OF 2 | |
| | | THIS DRAWING CONTAINS INFORMATION THAT IS PROPRIETARY TO MOLEX INCORPORATED AND SHOULD NOT BE USED WITHOUT WRITTEN PERMISSION | | | | | A3 |

9 8 7 6 5 4 3 2 1

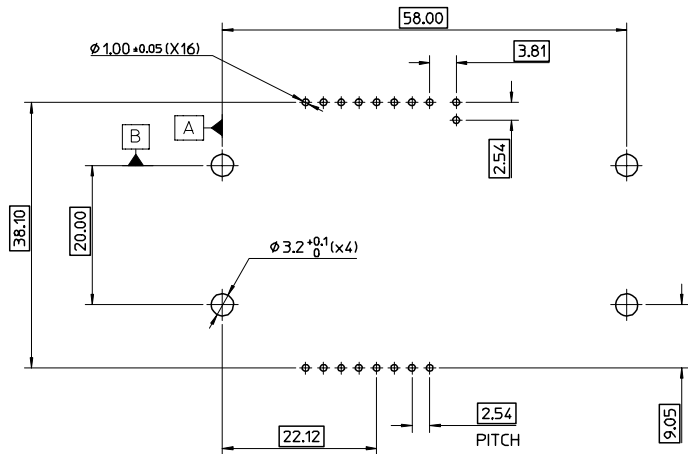

RECOMMENDED 16CKT PCB LAYOUT
 RECOMMENDED BOARD THICKNESS 1.57±0.1
 ALL HOLE POSITIONAL TOLERANCES ARE $\pm \phi 0.1$
 (VIEW FROM CONNECTOR SIDE)

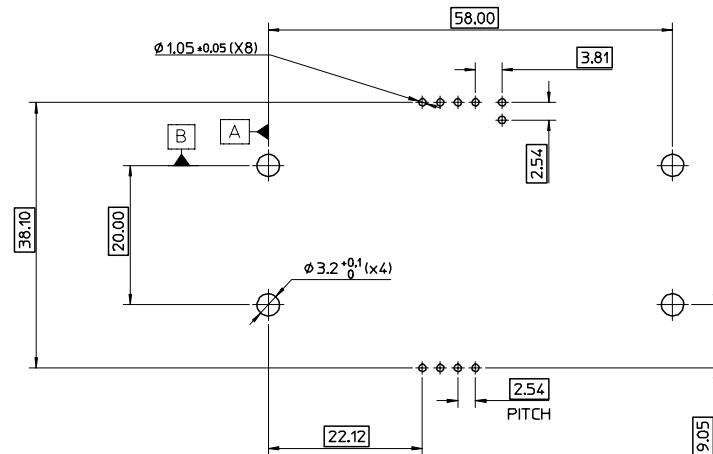

RECOMMENDED 8CKT PCB LAYOUT
 RECOMMENDED BOARD THICKNESS 1.57±0.1
 ALL HOLE POSITIONAL TOLERANCES ARE $\pm \phi 0.1$
 (VIEW FROM CONNECTOR SIDE)

| | | | | | | | | | | |
|-------------|-----------|-------------------------------|-----------------|---|----------|----------|--|------------------------|--------------------|----|
| SEE SHEET 1 | EC NO: | 2003/02/07 | QUALITY SYMBOLS | GENERAL TOLERANCES (UNLESS SPECIFIED) | | SCALE | DESIGN UNITS | THIRD ANGLE PROJECTION | REVISE ON CAD ONLY | |
| | DRAWN BY: | DBYRNES | | mm | INCH | 2:1 | METRIC | | | |
| | CHKD: | | | 4 PLACES | ± --- | ± --- | DIMENSION STYLE | | TITLE | |
| | APPR: | | | 3 PLACES | ± --- | ± --- | MM ONLY | | | |
| REV | | 2 PLACES | ± 0.1 | ± --- | DRAWN BY | DATE | THOLE FRICTION SMARTCARD READER WITH NC SWITCH 8/16CKT | | | |
| | | 1 PLACE | ± 0.2 | ± --- | DMCNAMAR | 01/05/17 | | | | |
| | | ANGULAR ± 2 ° | | CHECKED BY | | DATE | MOLEX INCORPORATED | | | |
| | | DRAFT WHERE APPLICABLE | | ROCONNOR | | 01/05/17 | | | | |
| | | MUST REMAIN WITHIN DIMENSIONS | | APPROVED BY | | DATE | MATERIAL NO. | DOCUMENT NO. | SHEET NO. | |
| | | | | MWILHITE | | 01/05/17 | SEE CHART | SD-91506-001 | 2 OF 2 | |
| | | | | THIS DRAWING CONTAINS INFORMATION THAT IS PROPRIETARY TO MOLEX INCORPORATED AND SHOULD NOT BE USED WITHOUT WRITTEN PERMISSION | | | | | | A2 |