

REVISIONS		
ISS	ZONE	DESCRIPTION\PER REQUEST\DATE

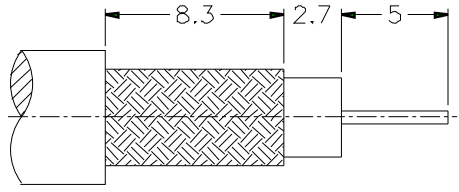

RECOMMENDED
CABLE STRIPPING DIM'S

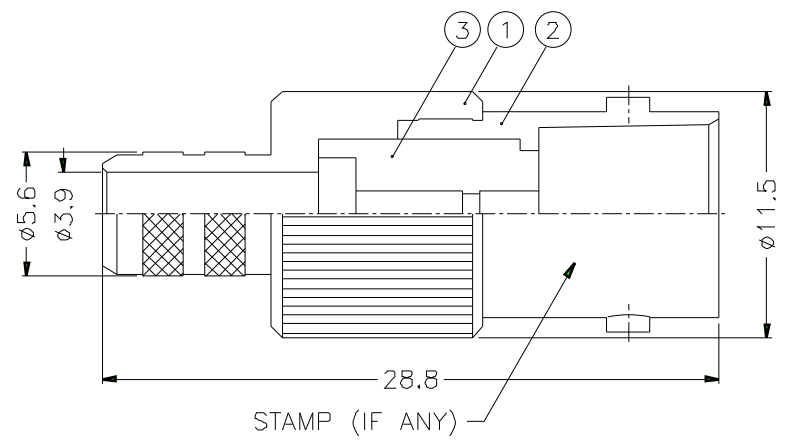
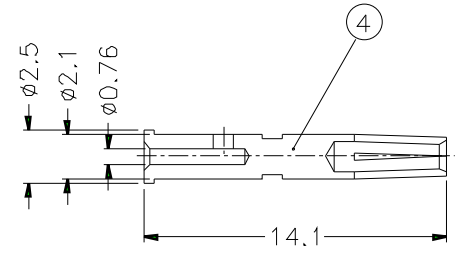
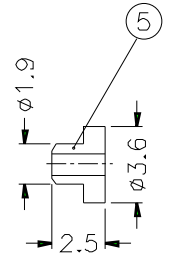
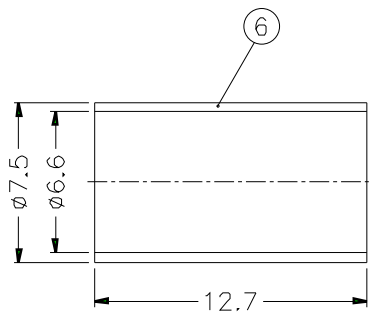

STAMP (IF ANY)

- NOTES: FINISH (PLATING THICKNESS IN MICRO-INCHES)
1. BRASS PER QQ-B-626
 2. NICKEL PL. 100 MIN. THICK OVER COPPER STRIKE
 3. PHOSPHOR BRONZE PER QQ-B-750
 4. GOLD PL. 3 MIN THICK OVER NICKEL PL 100 MIN. THICK OVER COPPER STRIKE
 5. TEFLON MIL-P-19468
 6. JIS H3250, C 2700

1. CRIMPED FERRULE
HEX CRIMP SIZE .255"
2. CRIMPED CONTACT PIN
HEX CRIMP SIZE .068"

NO.	DESCRIPTION	MATERIAL	FINISH	Q'TY	DRAWING NO.
6	FERRULE	NOTE 6	NOTE 2	1	FR-75/66X127
5	INSULATOR	DELFIN	NATURAL	1	B50000-11-36/1
4	CONTACT PIN	NOTE 3	NOTE 4	1	B74000-8-25/076
3	INSULATOR	NOTE 5	NATURAL	1	B74000-3T-75
2	BODY	NOTE 1	NOTE 2	1	B74000-2
1	HOUSING	NOTE 1	NOTE 2	1	B70000-1-56/39

DIMENSIONS ARE IN MILLIMETERS			
UNLESS OTHERWISE SPECIFIED TOLERANCES			
0.5-6	=	±0.2	
6-30	=	±0.4	
30-120	=	±0.6	
120-315	=	±1	
315-1000	=	±1.6	
1000-2000	=	±2.4	

PART NO.	B6121A1-NT3G-3-75	
APPROVED	DATE	10-11-01'
CHECKED	DATE	10-11-01'
DRAWN	DATE	10-11-01'
FILE NO.		

Amphenol	
TITLE	BNC CRIMP JACK
DRAWING NO.	KJ-B6121A1-NT3G-62AU-75
ITEM NO.	