

Series 330 - 1206 with Lens

thin film technology

preliminary

Features

- with lens. mounting from backside of PCB
- view angle 40°
- size 1206: 3.2(L) x 1.6(W) x 1.9(H) mm
- circuit substrate: glass laminated epoxy
- devices are ROHS conform
- lead free solderable. soldering pads: gold plated
- taped in 8 mm blister tape. cathode to transporting perforation
- all devices sorted into luminous intensity classes
- taping: face-up (TU) or face-down (TD) possible
- high luminous intensity types
- on request sorted in color classes

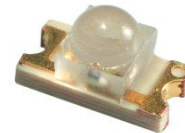

Absolute Maximum Ratings

| $I_{F, max}$ [mA] | $I_{F, P}$ [mA] $tp \leq 100 \mu s$ $\tau=1: 10$ | V_R [V] | $I_{R, max}$ [μA] | Thermal resistance R_{thJA} [K / W] | T_{Op} [°C] | T_{St} [°C] |
|-------------------|--|-----------|--------------------------|---------------------------------------|---------------|---------------|
| 30 | 70 | 5 | 100 | 450 | -40...85 | -40...85 |

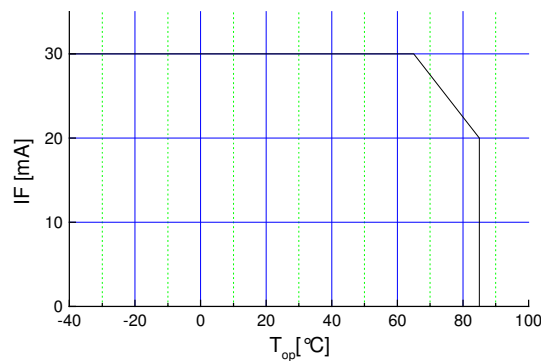

Maximal forward current (DC) characteristic

Electro-Optical Characteristics

| Type | Emitting color | Marking at | Measurement I_F [mA] | V_F [V] | | λ_d / λ_p^* [nm] | I_v [mcd] | |
|-------------|----------------|------------|------------------------|-----------|-----|--------------------------------|-------------|------|
| | | | | typ | max | | min | typ |
| OLS-330 MY | yellow | anode | 20 | 2.1 | 2.6 | 589 | 900 | 1400 |
| OLS-330 MD | orange | anode | 20 | 2.1 | 2.6 | 615 | 1400 | 2500 |
| OLS-330 MSD | red | anode | 20 | 2.1 | 2.6 | 624 | 900 | 1400 |

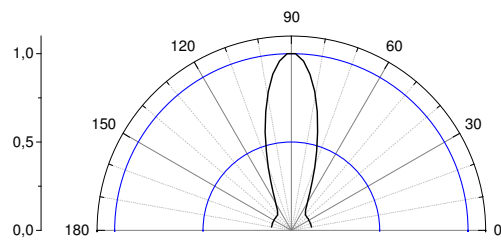

view angle

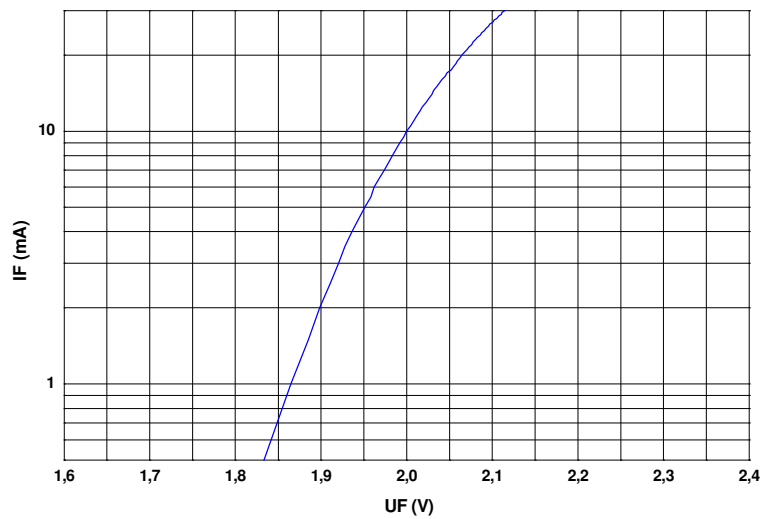

$U_F - I_F$
characteristic

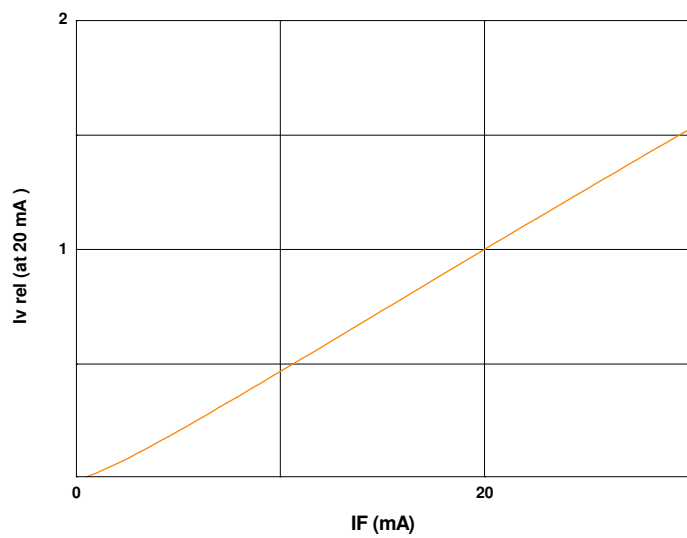

$I_F - I_{v,rel}$
characteristic

Outline Drawing

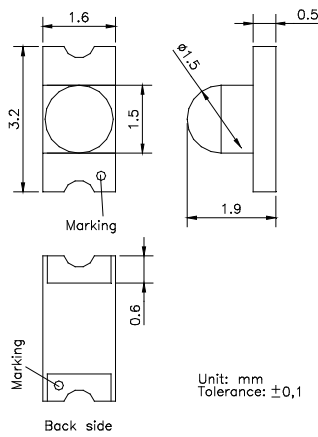

Recommended Soldering Patterns

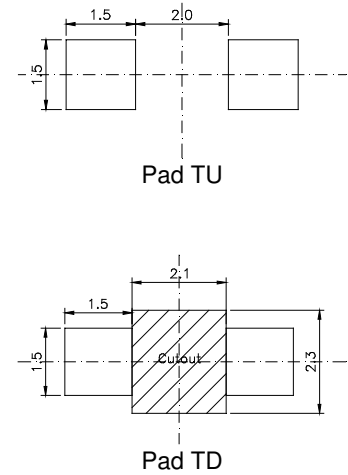

Soldering Conditions

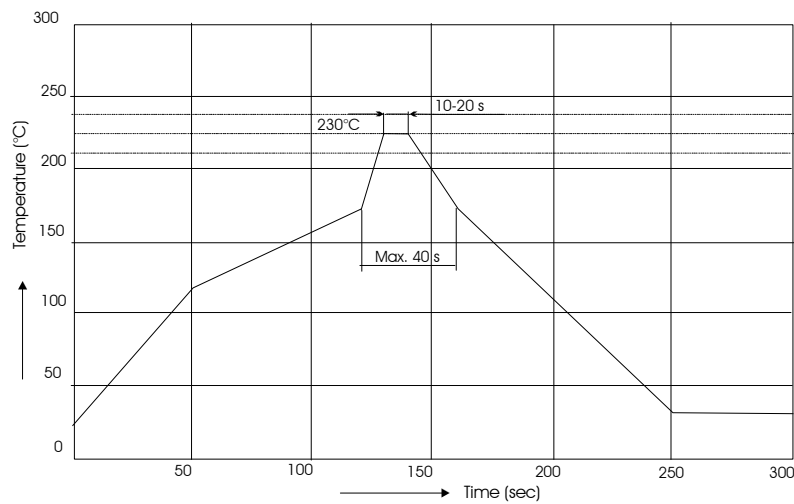

IR reflow
soldering
profile

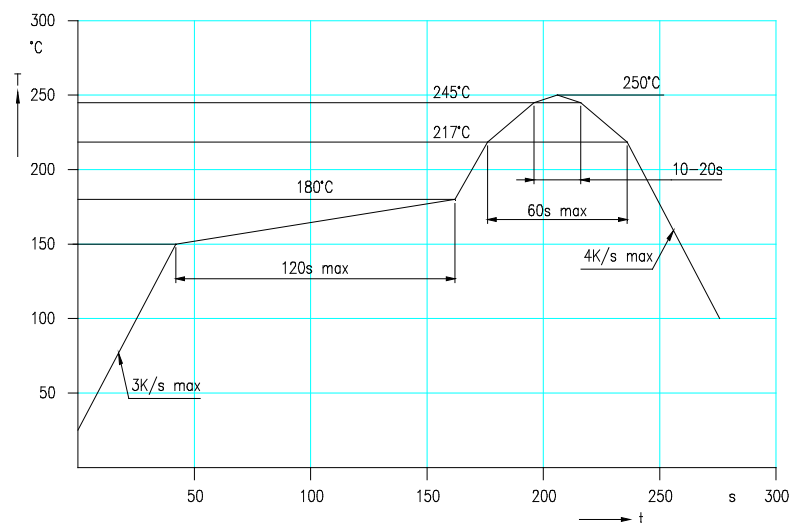

IR reflow
soldering
profile for lead
free soldering

Manual soldering: max power of iron 25W/ 3s/ 300°C

Ordering Code For Parts

Series Color Encapsulation Packaging

OLS-330

-

???????

-

X

-

?

TU - taped up

TD - taped down

X - uncolored clear

Type definition, e.g. OLS-330 MY-X -TU

LED Luminous Intensity Groups And Subgroups [mcd]

(general information – not this device specific)

| | | | | | | | | | | | |
|----|-------|---|-------|-----|-------|---|-------|-----|------|---|------|
| C: | 0.28 | - | 0.45 | C1: | 0.28 | - | 0.36 | P1: | 45 | - | 56 |
| D: | 0.45 | - | 0.71 | C2: | 0.36 | - | 0.45 | P2: | 56 | - | 71 |
| E: | 0.71 | - | 1.12 | D1: | 0.45 | - | 0.56 | Q1: | 71 | - | 90 |
| F: | 1.12 | - | 1.80 | D2: | 0.56 | - | 0.71 | Q2: | 90 | - | 112 |
| G: | 1.80 | - | 2.80 | E1: | 0.71 | - | 0.90 | R1: | 112 | - | 140 |
| H: | 2.80 | - | 4.50 | E2: | 0.90 | - | 1.12 | R2: | 140 | - | 180 |
| J: | 4.50 | - | 7.10 | F1: | 1.12 | - | 1.40 | S1: | 180 | - | 224 |
| K: | 7.10 | - | 11.20 | F2: | 1.40 | - | 1.80 | S2: | 224 | - | 280 |
| L: | 11.20 | - | 18.00 | G1: | 1.80 | - | 2.24 | T1: | 280 | - | 355 |
| M: | 18 | - | 28 | G2: | 2.24 | - | 2.80 | T2: | 355 | - | 450 |
| N: | 28 | - | 45 | H1: | 2.80 | - | 3.55 | U1: | 450 | - | 560 |
| P: | 45 | - | 71 | H2: | 3.55 | - | 4.50 | U2: | 560 | - | 710 |
| Q: | 71 | - | 112 | J1: | 4.50 | - | 5.60 | V1: | 710 | - | 900 |
| R: | 112 | - | 180 | J2: | 5.60 | - | 7.10 | V2: | 900 | - | 1120 |
| S: | 180 | - | 280 | K1: | 7.10 | - | 9.00 | W1: | 1120 | - | 1420 |
| T: | 280 | - | 450 | K2: | 9.00 | - | 11.20 | W2: | 1420 | - | 1800 |
| U: | 450 | - | 710 | L1: | 11.20 | - | 14.00 | X1: | 1800 | - | 2250 |
| V: | 710 | - | 1120 | L2: | 14.00 | - | 18.00 | X2: | 2250 | - | 2800 |
| W: | 1120 | - | 1800 | M1: | 18.00 | - | 22.40 | Y1: | 2800 | - | 3550 |
| X: | 1800 | - | 2800 | M2: | 22.40 | - | 28.00 | Y2: | 3550 | - | 4500 |
| Y: | 2800 | - | 4500 | N1: | 28.00 | - | 35.50 | Z1: | 4500 | - | 5750 |
| Z: | 4500 | - | 7100 | N2: | 35.50 | - | 45.00 | Z2: | 5750 | - | 7100 |

Measured according to CIE 127. All SMD-LEDs are 100% measured and selected on full automated equipment with an accuracy of ± 11 %.

**Special service: Brightness selection in sub selections possible.
Color selection in 3 sub selections possible (each subgroup per reel).**

Tape And Reel Packing

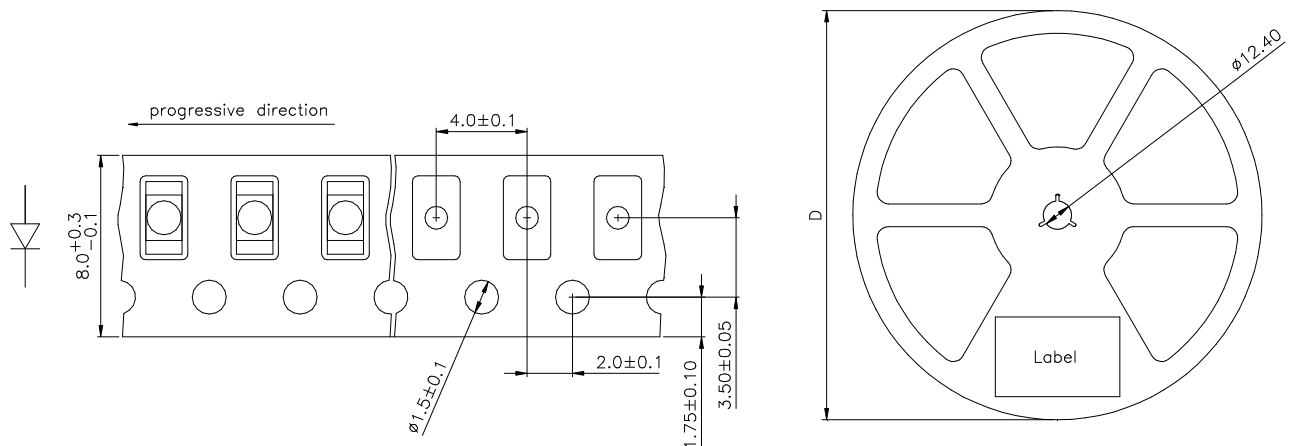

| D | Parts/reel |
|--------|------------|
| 180 mm | 2000 |
| 330 mm | 8000 |

Packing: The reel is sealed in special plastic bag with integrate ESD protection (MIL - STD 81705) including a silica dry-pack

Label

| | | |
|-----------------|--------------------|---|
| Order No. | XXXXXXXXXX | Customer order No. |
| Type | OLS-330 ?????-??-T | |
| Intensity group | ZZ | Color class: CC |
| Charge No. | 1122-AAAAAA | 11 Week – 22 year – A internal identification |
| Quantity | 9999 | |

Attention please:

The information describes the type of component and shall not considered as assured characteristics. Terms of delivery and rights to change reserved. Due to technical requirements components may contain dangerous substances. The data sheet may changed without prior information; the valid issue will be on our webpage in internet. Parameters can vary in different applications. All operating parameters must be validated for each customer application by the customer. OSA opto light does not have the responsibility for the reliability and the degradation behaviour of products made with OSA opto light diodes because they depend not only on the diode but also on the conditions of manufacture or design of the final products.

Packaging: Please use the recycling operators known to you.

Components used in life support devices or systems and safety systems must be expressly authorized for such purpose!