

# Low Capacitance TVS Diode Array

## PROTECTION PRODUCTS

### Description

The LCDA15-1 is a low capacitance transient voltage suppressor (TVS) diode array. It is designed to protect sensitive CMOS ICs from the damaging effects of ESD and lightning. Each device will protect one line in common (line-to-ground) mode. They are low capacitance (< 15pF) making them suitable for use on high-speed telecom and datacom interfaces without signal degradation.

The configuration of the LCDA15-1 has been optimized for easy layout on high density boards. The small SOT-143 package minimizes required board space. These devices will handle up to 15 Amps for an 8/20μs lightning impulse. The low inductance construction minimizes voltage overshoot during high current surges.

The LCDA15-1 may be used to protect ADSL interfaces, portable electronics, and wireless systems.

### Features

- ◆ Transient protection for high-speed data lines to IEC 61000-4-2 (ESD) ±15kV (air), ±8kV (contact) IEC 61000-4-4 (EFT) 40A (5/50ns) IEC 61000-4-5 (lightning) 15A (8/20μs)
- ◆ Configuration optimized for easy board layout
- ◆ Protects one line
- ◆ Low capacitance (<15pF) for high-speed interfaces
- ◆ Low clamping voltage
- ◆ Low leakage current
- ◆ Operating voltage: 15V
- ◆ Solid-state silicon-avalanche technology

### Mechanical Characteristics

- ◆ JEDEC SOT-143 package
- ◆ Molding compound flammability rating: UL 94V-0
- ◆ Marking : Marking code
- ◆ Packaging : Tape and Reel per EIA 481

### Applications

- ◆ ADSL Interfaces
- ◆ Serial/Parallel Interfaces
- ◆ High-Speed Data Lines
- ◆ Portable Electronics
- ◆ WAN/LAN Equipment
- ◆ Wireless Systems

### Circuit Diagram

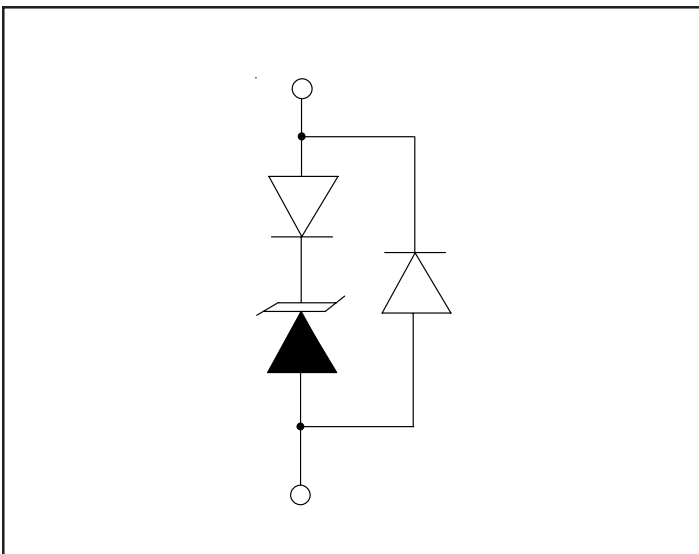

### Schematic & PIN Configuration

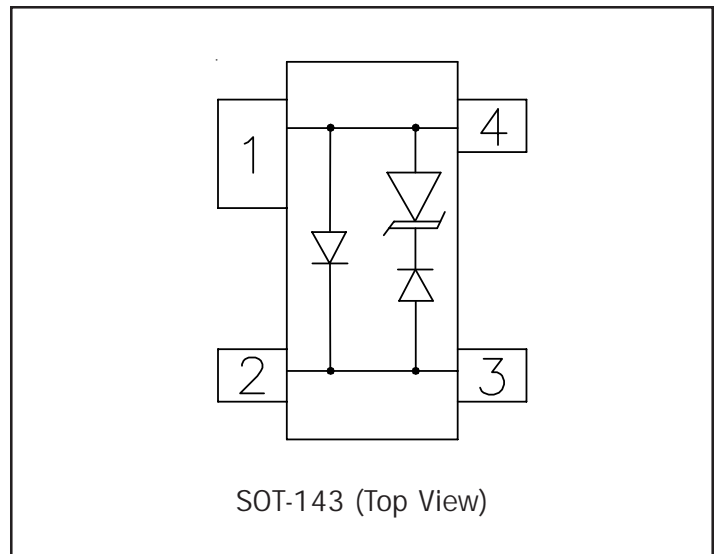

**PROTECTION PRODUCTS**
**Absolute Maximum Rating**

Rating	Symbol	Value	Units
Peak Pulse Power ( $t_p = 8/20\mu s$ )	$P_{pk}$	500	Watts
Peak Pulse Current ( $t_p = 8/20\mu s$ )	$I_{pp}$	15	A
Lead Soldering Temperature	$T_L$	260 (10 sec.)	$^{\circ}C$
Operating Temperature	$T_J$	-55 to +125	$^{\circ}C$
Storage Temperature	$T_{STG}$	-55 to +150	$^{\circ}C$

**Electrical Characteristics**

LCDA15-1						
Parameter	Symbol	Conditions	Minimum	Typical	Maximum	Units
Reverse Stand-Off Voltage	$V_{RWM}$				15	V
Reverse Breakdown Voltage	$V_{BR}$	$I_t = 1mA$	16.7			V
Reverse Leakage Current	$I_R$	$V_{RWM} = 15V, T=25^{\circ}C$			5	$\mu A$
Steering Diode Forward Voltage	$V_F$	$I_F = 1A$			1.5	V
Clamping Voltage	$V_C$	$I_{pp} = 1A, t_p = 8/20\mu s$			24	V
Clamping Voltage	$V_C$	$I_{pp} = 15A, t_p = 8/20\mu s$			33	V
Junction Capacitance	$C_j$	Between I/O pins and Ground $V_R = 0V, f = 1MHz$		8	15	pF

PROTECTION PRODUCTS

Typical Characteristics

Non-Repetitive Peak Pulse Power vs. Pulse Time

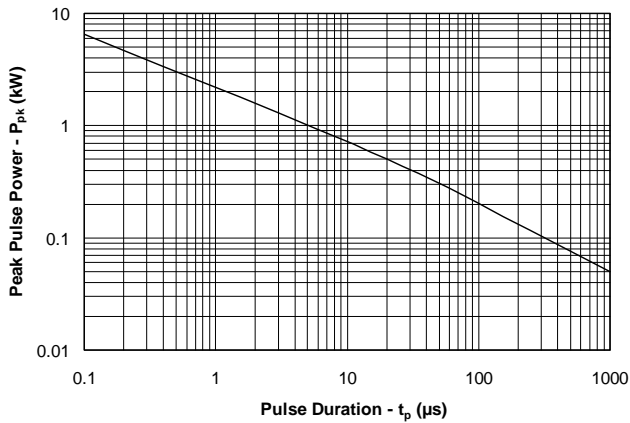

Power Derating Curve

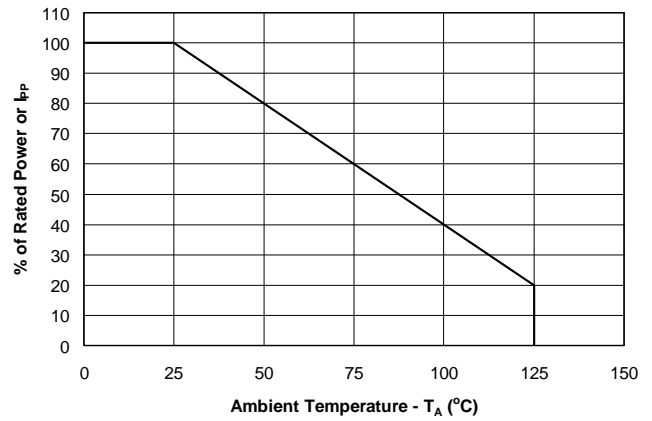

Pulse Waveform

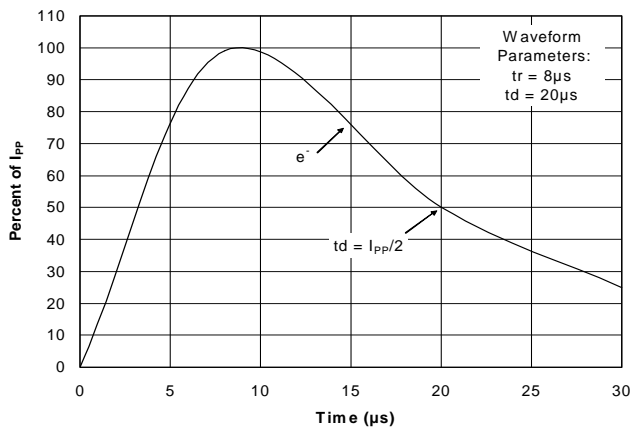

Clamping Voltage vs. Peak Pulse Current

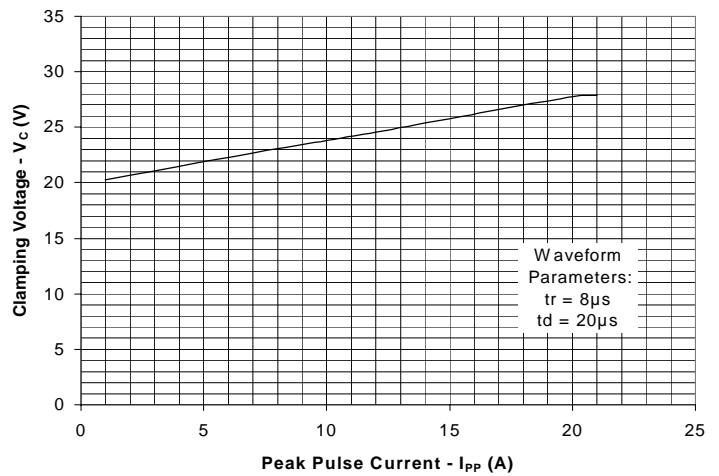

Capacitance vs. Reverse Voltage

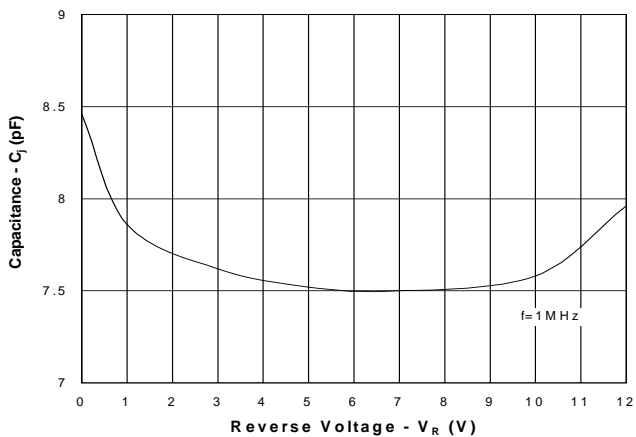

Forward Voltage vs. Forward Current

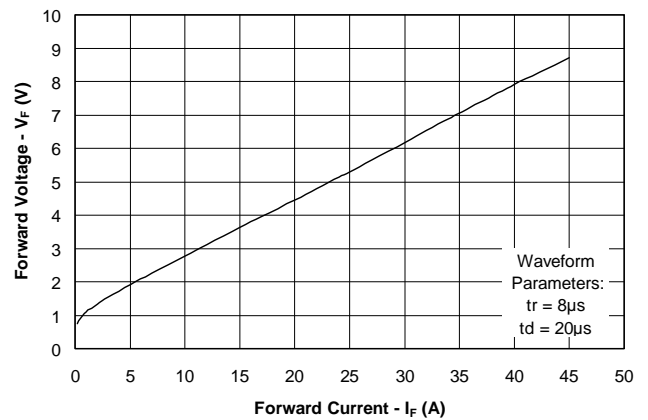

PROTECTION PRODUCTS

Applications Information

Device Connection for Protection of High-Speed Data Lines

The LCDA15-1 is designed to protect high-speed data lines from transient over-voltages which result from lightning and ESD. The device is designed to protect one unidirectional line in common mode (Line-to-Ground). For common mode protection, The signal is input at pins 2 and 3. Pins 1 and 4 are connected to ground. The ground connection should be made directly to the ground plane for best results.

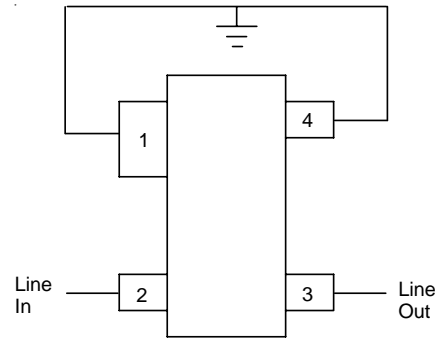

Figure 1 - Connection for Common Mode Protection (Line-to-Ground)

ADSL Protection

Figure 2 shows a typical ADSL schematic diagram with the LCDA15-1 configured to provide lightning and ESD protection for the sensitive ADSL line driver. The LCDA15-1 is connected from each line to ground on the IC side of the line. The LCDA15-1 should be grounded to the system ground to provide a proper reference.

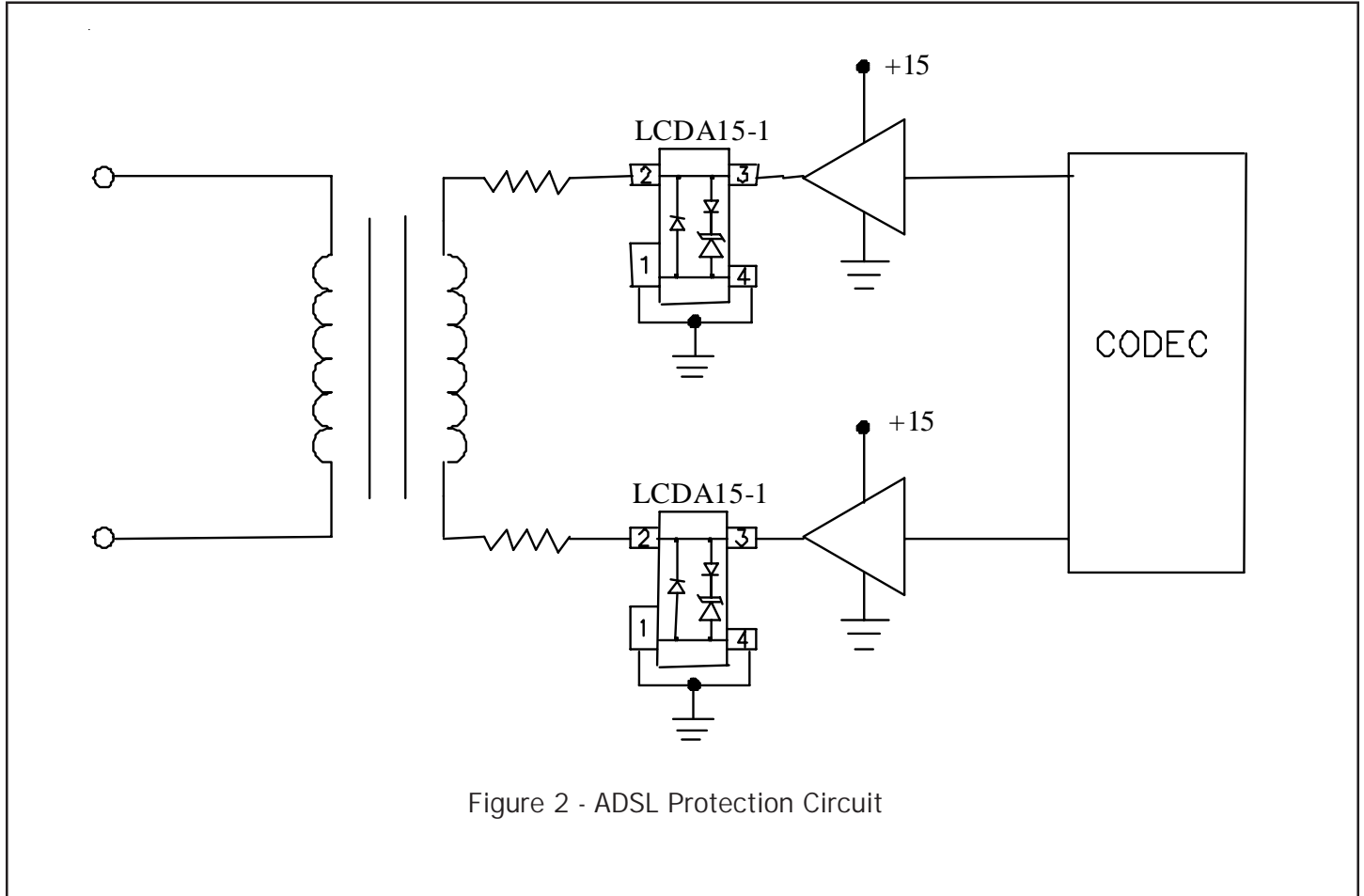
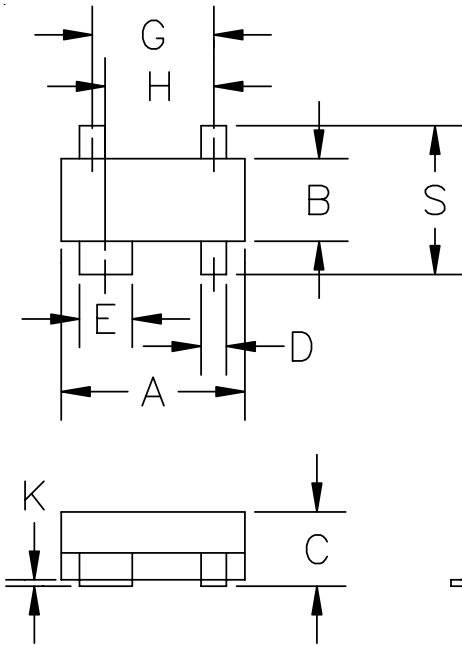

Figure 2 - ADSL Protection Circuit

PROTECTION PRODUCTS

Outline Drawing - SOT-143



DIM <sup>N</sup>	INCHES		MM		NOTE
	MIN	MAX	MIN	MAX	
A	.110	.120	2.80	3.04	—
B	.047	.055	1.20	1.40	—
C	.031	.047	.80	1.20	—
D	.014	.018	.37	.510	—
E	.030	.035	.76	.940	—
G	.076	BSC	1.92	BSC	—
H	.068	BSC	1.72	BSC	—
J	.003	.005	.085	.180	—
K	.002	.005	.013	0.10	—
L	.010	.022	—	.55	REF
S	.082	.104	2.10	2.64	—

Notes:

- (1) Controlling dimension: Inch (unless otherwise specified).
- (2) Dimension A and B do not include mold protrusions. Mold protrusions are .006" max.

Land Pattern - SOT-143

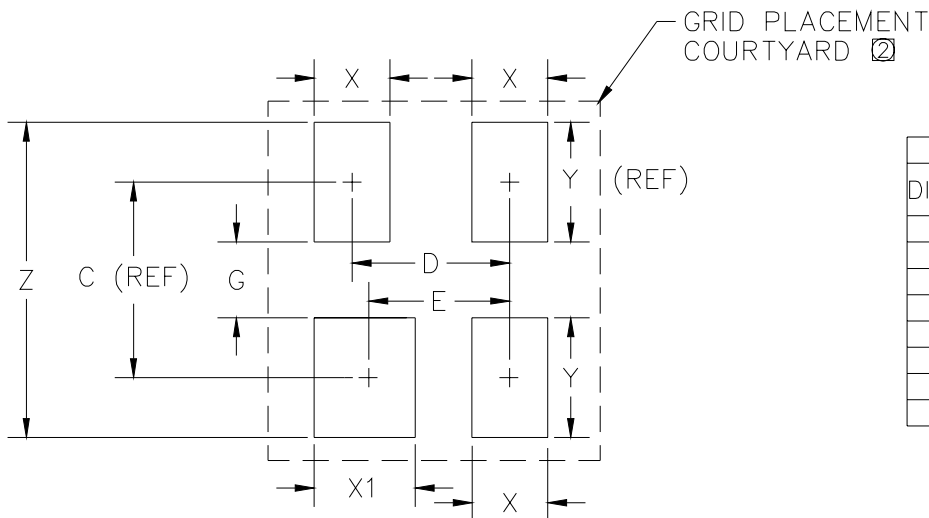

DIM <sup>N</sup>	INCHES		MM		NOTE
	MIN	MAX	MIN	MAX	
C	—	.087	—	2.20	—
D	.075	BSC	1.90	BSC	—
E	.067	BSC	1.70	BSC	—
G	.032	.040	.80	1.00	—
X	.032	.040	.80	1.00	—
X1	.040	.048	1.00	1.20	—
Y	—	.055	—	1.40	—
Z	.134	.140	3.40	3.60	—

② GRID PLACEMENT COURTYARD IS 8 X 8 ELEMENTS (4mm X 4mm) IN ACCORDANCE WITH THE INTERNATIONAL GRID DETAILED IN IEC PUBLICATION 97.

① CONTROLLING DIMENSION: MILLIMETERS.

**PROTECTION PRODUCTS****Marking Codes**

Part Number	Marking Code
LCDA15-1	15U

**Ordering Information**

Part Number	Working Voltage	Qty per Reel	Reel Size
LCDA15-1.TC	15V	3,000	7 Inch

**Contact Information**

Semtech Corporation  
Protection Products Division  
200 Flynn Road, Camarillo, CA 93012  
Phone: (805)498-2111 FAX (805)498-3804