

Hand Brushes

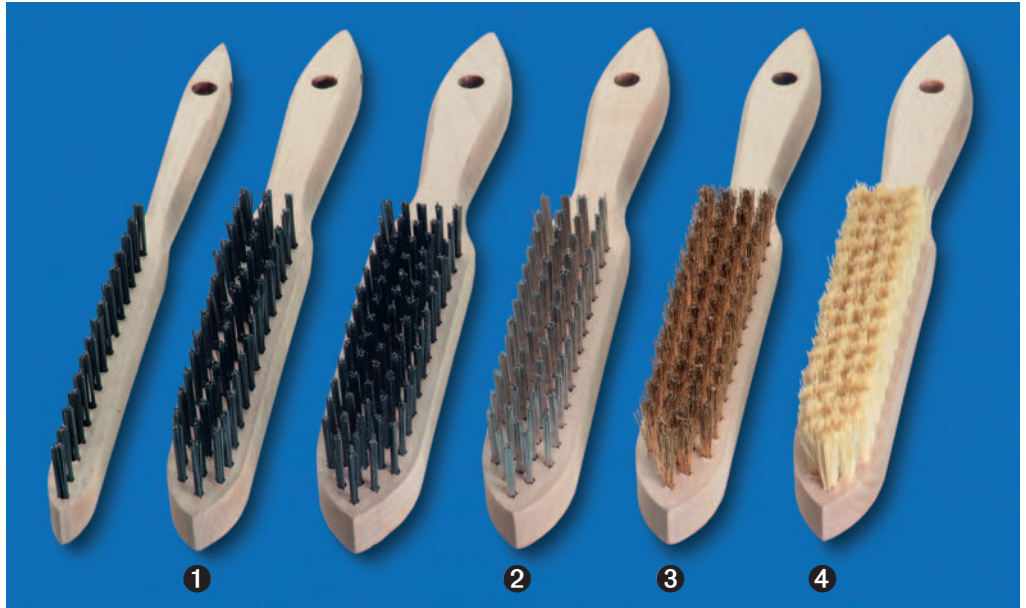
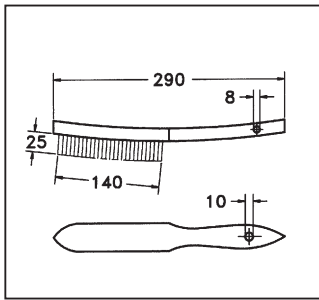

Hand Brushes

Filling	Rows Pack.	1 Art. No.	2 Art. No.	3 Art. No.	4 Art. No.	5 Art. No.	6 Art. No.
① steel straight 0.35/0.014"	12	100.011	100.021	100.031	100.041	100.051	100.061
steel straight 0.35/0.014"	100		100.020	100.030	100.040	100.050	
brassed steel 0.30/0.012"	12		105.421	105.431	105.441	105.451	105.461
brassed steel 0.30/0.012"	100		105.420	105.430	105.440	105.450	
steel crimped 0.20/0.008"	12		102.421	102.431	102.441		
steel crimped 0.30/0.012"	12	102.611	102.621	102.631	102.641	102.651	102.661
steel crimped 0.30/0.012"	100		102.620	102.630			
stainless crimped 0.15/0.006"	12		104.321	104.331	104.341	104.351	
stainless crimped 0.20/0.008"	12		104.421	104.431	104.441	104.451	
stainless crimped 0.35/0.014"	12	104.611	104.621	104.631	104.641	104.651	104.661
stainless crimped 0.35/0.014"	100			104.630	104.640		
② stainless straight 0.35/0.014"	12	103.711	103.721	103.731	103.741	103.751	103.761
stainless straight 0.35/0.014"	100		103.720	103.730	103.740		
stainless straight 0.30/0.012"-V4A	12		105.721	105.731	105.741	105.751	
brass crimped 0.15/0.006"	12		107.321	107.331	107.341	107.351	
brass crimped 0.25/0.010"	12	107.411	107.421	107.431	107.441	107.451	107.461
brass crimped 0.25/0.010"	100		107.420		107.440		
③ brass crimped 0.35/0.014"	12	107.611	107.621	107.631	107.641	107.651	107.661
brass crimped 0.35/0.014"	100			107.630	107.640		
brass straight 0.35/0.014"	12		106.621	106.631	106.641	106.651	
bronze crimped 0.20/0.008"	12			108.331	108.341	108.351	
nylon straight 0.40/0.016"	12		109.421	109.431	109.441	109.451	109.461
④ fibre white	12			109.731	109.741		
horse hair	12					109.851	

Other filling material and trim length on request.

Hand Brushes

Hand Brushes are used everywhere, in the metal industry, construction work, in the workshop. They are found in every tool box. The complete range contains all types of filling materials, from coarse steel to the finest brass

wire. The handles are made of beech wood with two hanging holes.

LESSMANN-Handbrushes are of superb quality and yet are economic due to a fully automated and efficient production facility. Using

modern marking systems individual printing of brands and EAN Bar Codes can be made. This is done by burning stamps or tampon printing at low cost. All above listed hand brushes have a bar code stamp.

Environmental hint:

LESSMANN hand brushes with a wooden body are certified in accordance with PEFC standards.

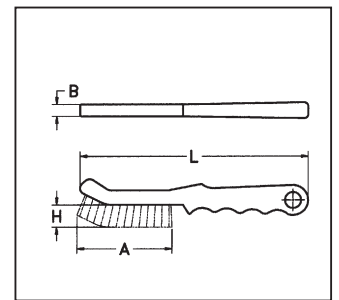

Special Hand Brushes

Filling	Rows	L	B	A	H	Pack.	Art. No.
		mm/inch	mm/inch	mm/inch	mm/inch		
Brake Caliper Brushes							
1 steel straight 0.35/0.014"	2 x 13	225 / 9	12 / 1/2	90 / 3 1/2	22 / 7/8	10	182.401
steel crimped 0.30/0.012"	2 x 13	225 / 9	12 / 1/2	90 / 3 1/2	22 / 7/8	10	182.411
2 stainless straight 0.35/0.014"	2 x 13	225 / 9	12 / 1/2	90 / 3 1/2	22 / 7/8	10	182.421
3 brass crimped 0.25/0.010"	2 x 13	225 / 9	12 / 1/2	90 / 3 1/2	22 / 7/8	10	182.451
steel straight 0.35/0.014"	2 x 13	225 / 9	12 / 1/2	90 / 3 1/2	14 / 5/8 / 22 / 7/8*	10	182.431

*Special hard brushes

Hand Brushes with Plastic Handles

steel straight 0.35/0.014"	2	285 / 11 1/4	23 / 1	130 / 5 1/8	25 / 1	10	185.121
steel straight 0.35/0.014"	3	285 / 11 1/4	31 / 1 1/4	130 / 5 1/8	25 / 1	10	185.131
steel straight 0.35/0.014"	4	285 / 11 1/4	36 / 1 1/2	130 / 5 1/8	25 / 1	10	185.141
stainless crimped 0.35/0.014"	2	285 / 11 1/4	23 / 1	130 / 5 1/8	25 / 1	10	185.421
stainless crimped 0.35/0.014"	3	285 / 11 1/4	31 / 1 1/4	130 / 5 1/8	25 / 1	10	185.431
5 stainless crimped 0.35/0.014"	4	285 / 11 1/4	36 / 1 1/2	130 / 5 1/8	25 / 1	10	185.441
brass straight 0.35/0.014"	2	285 / 11 1/4	23 / 1	130 / 5 1/8	25 / 1	10	185.621
brass straight 0.35/0.014"	3	285 / 11 1/4	31 / 1 1/4	130 / 5 1/8	25 / 1	10	185.631
brass straight 0.35/0.014"	4	285 / 11 1/4	36 / 1 1/2	130 / 5 1/8	25 / 1	10	185.641

Hand Brushes with Two-Components Handles

NEW 4 stainless crimped 0.35/0.014"	3	285 / 11 1/4	31 / 1 1/4	130 / 5 1/8	25 / 1	10	186.431
--	---	--------------	------------	-------------	--------	----	----------------

Brake Caliper Brushes ROKI

This brush has been manufactured in co-operation with the automobile industry. This brush is used for cleaning off clogged lining deposits when changing brake pad linings. Thus the brush is very slim with a heavy straight wire filling. Made in this way it prevents damage to sensitive brake areas during use.

The brush 182.431 has to the top a sloping filling and is therefore extra hard. New is the two-components-handle with the latest ergonomical aspects. Because of the design and the ergonomic handle this brush is remarkably versatile to use.

Hand Brushes with Plastic Body

The remarkable feature of these hand brushes is their plastic body of PP (polypropylene) which makes them the perfect tool for the food industry.

Hand Brushes with Two-Components Handles

apply to other requirements of modern high quality tools with best ergonomics.

Special Hand Brushes

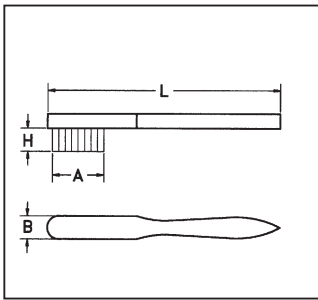

Special Hand Brushes

Filling	Rows	L	B	A	H	Pack.	Art. No.
1 Rivet Brushes							
steel straight 0.35/0.014"	3 x 15	290 / 11 3/8	35 / 1 1/2	135 / 5 3/8	35 / 1 1/2	12	120.801
stainless straight 0.35/0.014"	3 x 15	290 / 11 3/8	35 / 1 1/2	135 / 5 3/8	35 / 1 1/2	12	120.811
stainless straight 0.30/0.012" - V4A	3 x 15	290 / 11 3/8	35 / 1 1/2	135 / 5 3/8	35 / 1 1/2	12	120.831
2 Hand Brushes with Scraper							
steel straight 0.35/0.014"	4 x 15	290 / 11 3/8	35 / 1 1/2	140 / 5 1/2	25 / 1	12	120.401
steel straight 0.35/0.014"	6 x 15	290 / 11 3/8	45 / 1 3/4	140 / 5 1/2	25 / 1	12	120.601
3 Hand Brushes Heavy Duty							
NEW steel straight 0.35/0.014"	2 x 16	310 / 12 1/4	30 / 1 1/4	150 / 6	32 / 1 1/4	12	136.101
steel straight 0.35/0.014"	3 x 16	310 / 12 1/4	35 / 1 1/2	150 / 6	32 / 1 1/4	12	136.102
steel straight 0.35/0.014"	4 x 16	310 / 12 1/4	40 / 1 3/8	150 / 6	32 / 1 1/4	12	136.103
Hand Brushes Export Model							
4 steel straight 0.35/0.014"	4 x 17	300 / 12	30 / 1 1/4	130 / 5 1/8	25 / 1	12	122.401
5 steel straight 0.35/0.014"	4 x 19	350 / 14	30 / 1 1/4	160 / 6 3/8	30 / 1 1/4	6	122.801
6 Universal Wire Brushes							
brassed steel 0.30/0.012"	1	260 / 10 1/4	10 / 3/8	135 / 5 3/8	28 / 1	24	056.001
steel crimped 0.35/0.014"	1	260 / 10 1/4	10 / 3/8	135 / 5 3/8	28 / 1	24	056.301
stainless crimped 0.30/0.012"	1	260 / 10 1/4	10 / 3/8	135 / 5 3/8	28 / 1	24	056.501
brass crimped 0.30/0.012"	1	260 / 10 1/4	10 / 3/8	135 / 5 3/8	28 / 1	24	056.701



Sectoral or special universal – LESSMANN is always conscious of being able to supply the correct brush for each individual area of application. For example, with these models of hand brushes, for special demands in different areas of application.

Rivet Brushes

The V shaped filling material enables the removal of slag and scale from normally hard to reach welds and fillet welds.

Hand Brushes with Scraper

For painters and bricklayers in the construction industry. These brushes are ideal for scraping off dirt or cement splashes.

Hand Brushes, Heavy Duty

These models have a larger wooden handle and a longer and dense wire filling than our standard models.

Universal Wire Brushes

For many uses, especially in the Do It Yourself section.

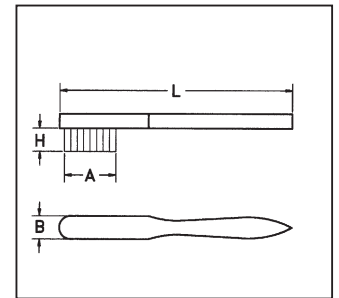
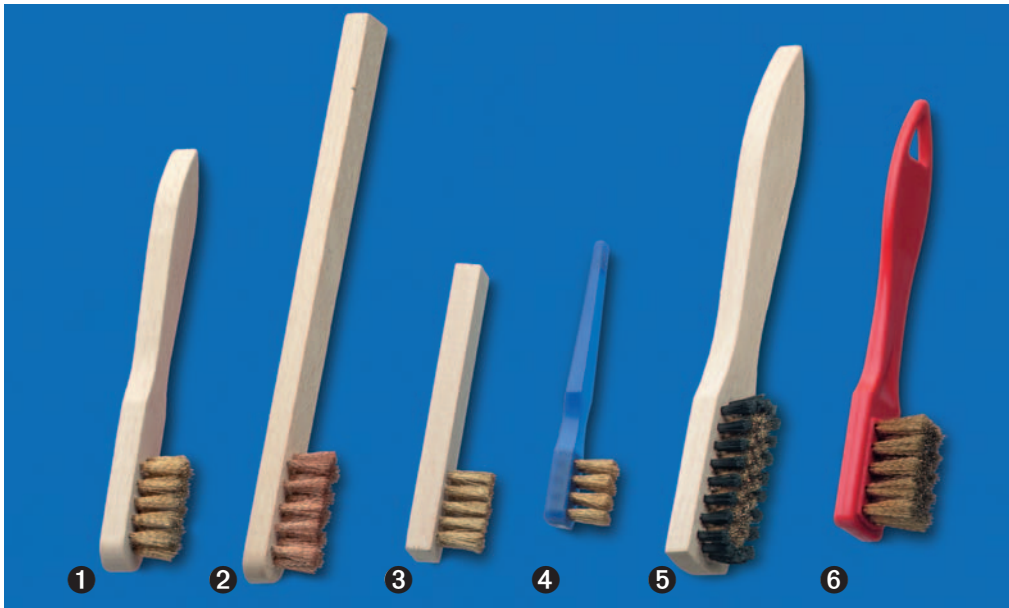

Standard Spark Plug Brushes

	Filling	Rows	L mm / inch	B mm / inch	A mm / inch	H mm / inch	Pack. 	Art. No.
1	brass crimped 0.15/0.006"	3 x 5/6	150 / 6	15 / 5/8	35 / 1 1/2	15 / 5/8	12	125.211
	steel crimped 0.15/0.006"	3 x 5/6	150 / 6	15 / 5/8	35 / 1 1/2	15 / 5/8	12	125.201
	stainless crimped 0.15/0.006"	3 x 5/6	150 / 6	15 / 5/8	35 / 1 1/2	15 / 5/8	12	125.231
	brass crimped 0.15/0.006" / PPN	3 x 5/6	150 / 6	15 / 5/8	35 / 1 1/2	15 / 5/8	12	125.221
	brass crimped 0.15/0.006"	3 x 5/6	150 / 6*	15 / 5/8	40 / 1 3/8	15 / 5/8	12	125.311
2	bronze crimped 0.15/0.006"	3 x 5/6	200 / 8	15 / 5/8	40 / 1 3/8	15 / 5/8	12	132.801
	stainless crimped 0.20/0.008"	3 x 5/6	150 / 6	15 / 5/8	30 / 1 1/4	15 / 5/8	12	125.241
	nylon straight 0.30/0.012"	3 x 5/6	150 / 6	15 / 5/8	30 / 1 1/4	15 / 5/8	12	125.251

* Wooden body varnished

Small Spark Plug Brushes

3	brass crimped 0.15/0.006"	2 x 5	100 / 4	15 / 5/8	25 / 1	15 / 5/8	50	125.111
4	brass crimped 0.15/0.006"	2 x 4	100 / 4*	12 / 1/2	22 / 7/8	12 / 1/2	50	182.001

* Plastic body

Large Spark Plug Brushes

	brass crimped 0.15/0.006"	5 x 8/10	190 / 7 1/2	24 / 1	55 / 2 1/4	18 / 3/4	12	125.511
5	brass crimped 0.15/0.006" / PPN	5 x 8/10	190 / 7 1/2	24 / 1	55 / 2 1/4	12 / 1/2	12	125.521
6	brass crimped 0.15/0.006"	4 x 6	155 / 6*	22 / 7/8	40 / 1 3/8	18 / 3/4	12	182.331

* Plastic body

Spark Plug Brushes

These small brushes are for all fine brushwork requiring thin wire. They are available in different sizes and filling materials. The models 182.001 and 182.331 have plastic bodies, the other models have a beech wood body. The body of 125.311 is varnished.

Fine Scratch Brushes

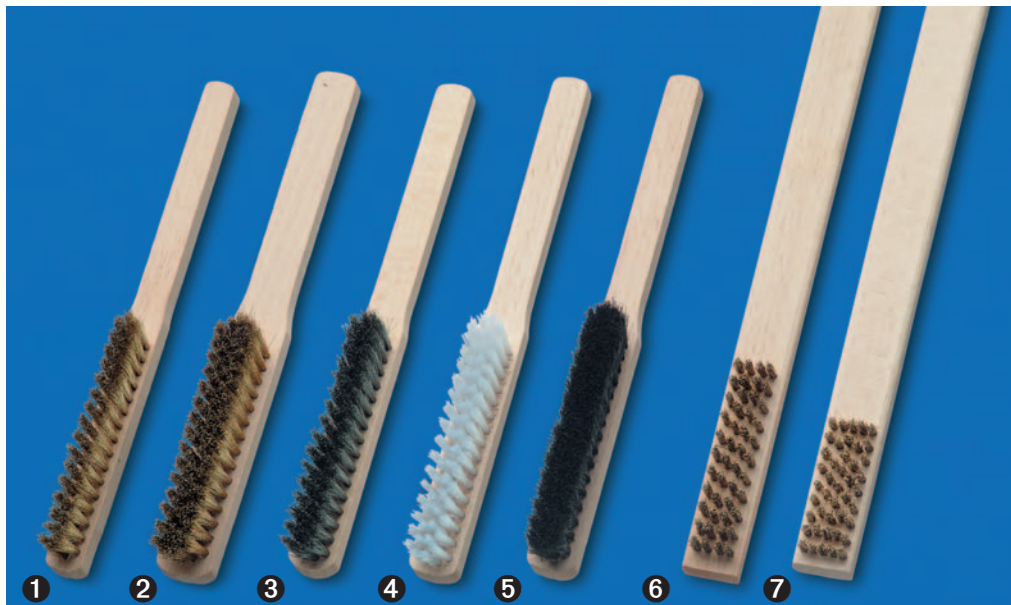
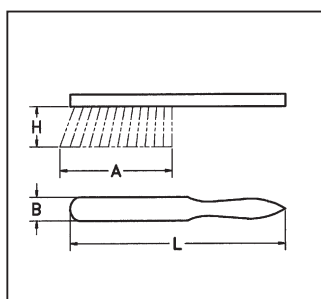

Fine Brushes

Filling	Rows	L mm / inch	B mm / inch	A mm / inch	H mm / inch	Pack. 	Art. No.
1 brass crimped 0.15/0.006"	3	225 / 9	16 / 5/8	110 / 4 3/8	20 / 3/4	12	126.311
brass crimped 0.15/0.006"	4	225 / 9	20 / 3/4	110 / 4 3/8	20 / 3/4	12	126.411
2 brass crimped 0.15/0.006"	5	225 / 9	24 / 1	110 / 4 3/8	20 / 3/4	12	126.511
brass crimped 0.15/0.006"	6	225 / 9	28 / 1	110 / 4 3/8	20 / 3/4	12	126.611
brass crimped 0.15/0.006"	8	225 / 9	36 / 1 1/2	110 / 4 3/8	20 / 3/4	12	126.811
brass crimped 0.08/0.003"	4	225 / 9	20 / 3/4	110 / 4 3/8	20 / 3/4	12	126.441
brass crimped 0.10/0.004"	4	225 / 9	20 / 3/4	110 / 4 3/8	20 / 3/4	12	126.431
3 steel crimped 0.15/0.006"	4	225 / 9	20 / 3/4	110 / 4 3/8	20 / 3/4	12	126.401
stainless crimped 0.15/0.006"	4	225 / 9	20 / 3/4	110 / 4 3/8	20 / 3/4	12	126.481
4 nylon straight 0.30/0.012"	4	225 / 9	20 / 3/4	110 / 4 3/8	20 / 3/4	12	126.451
5 horse hair	4	225 / 9	20 / 3/4	110 / 4 3/8	20 / 3/4	12	126.472

Special Brushes

6 brass crimped 0.35/0.014"	4 x 11/12	350 / 14	22 / 7/8	80 / 3	10 / 3/8	12	137.701
brass crimped 0.30/0.012"	4 x 11/12	450 / 17 3/4	22 / 7/8	80 / 3	8 / 5/16	12	138.705
7 brass crimped 0.30/0.012"	5 x 9	700 / 27 1/2	25 / 1	54 / 2 1/4	6 / 1/4	12	138.704

Gas Cooker Brushes

brass crimped 0.25/0.010"	2 x 10	200 / 8	15 / 5/8	80 / 3	19 / 3/4	12	132.701
---------------------------	--------	---------	----------	--------	----------	----	----------------

Fine Scratch Brushes

Also called watchmaker and goldsmith brushes. The brushes have a very high density of filling wires and are available in different widths. The brushes filled with nylon are used among other things to apply solvents and other cleansing agents.

Gas Cooker Brushes and Special Brushes

The brushes were manufactured according to our customers' specification and show variations, which are possible through our flexible manufacturing procedures.