

Art.-Number: 701118

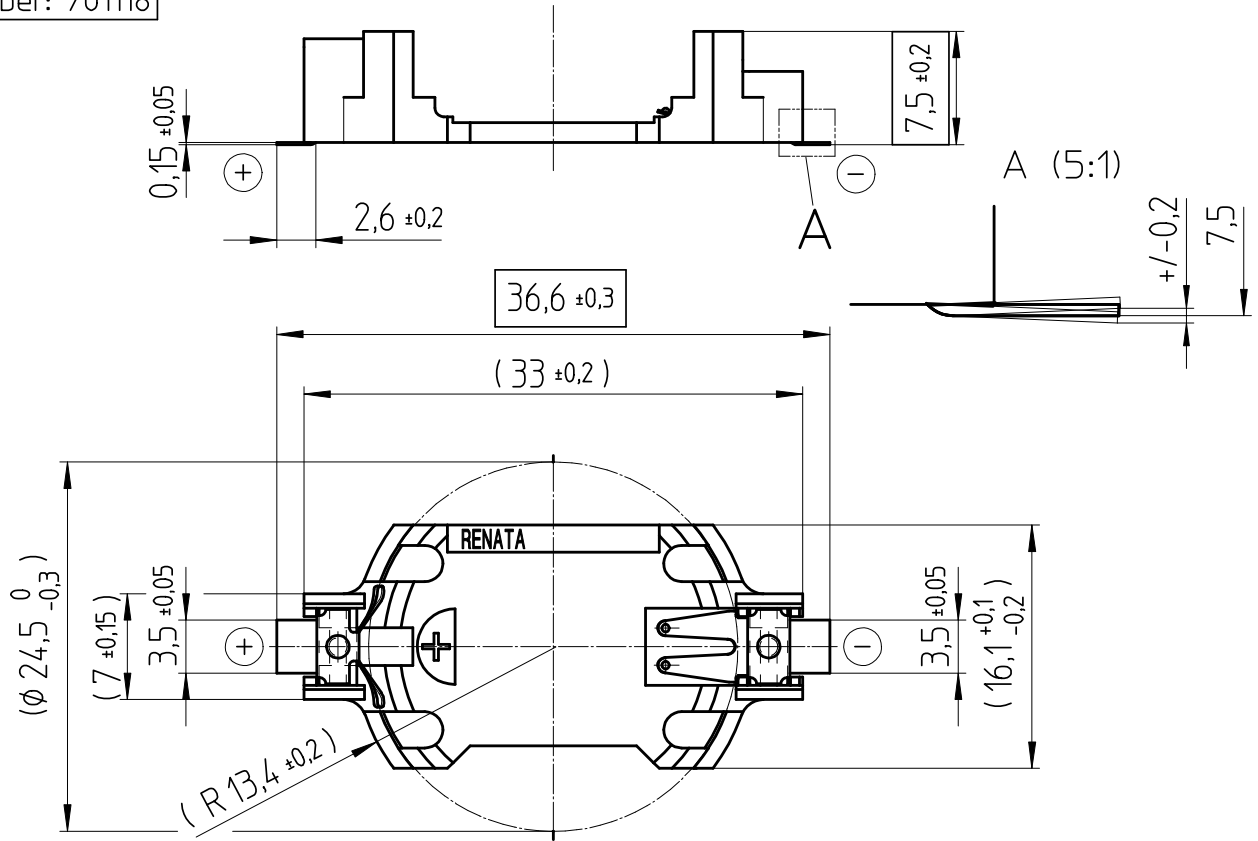

Zone for soldering

Zone for adhesive fixation
(as reference only)

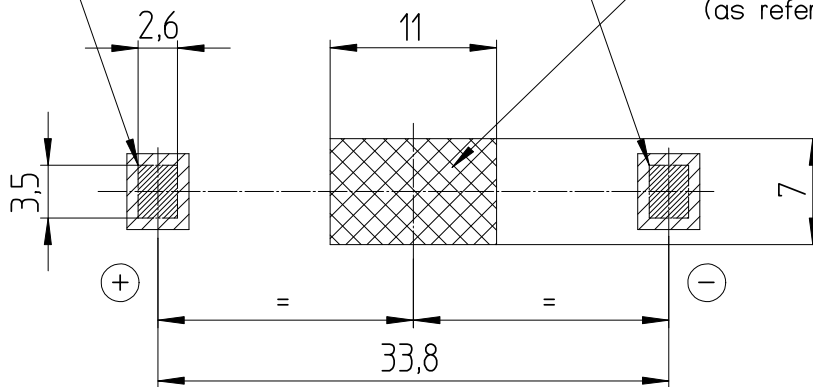

Layout
Top view

- Samples can deviate in the execution from the serie.

Holder material : heat resistant, glass-fiber reinforced LCP

Battery contacts : spring stainless steel 301 nickel plated, thickness 10µm

Solder contacts : spring stainless steel 301 solder plated throughout 100% Sn, thickness 10µm

- Dimensions and tolerances can be specified only after the testing of the devices for the mass production definitely

All framed values will be used for dimension checking !

Rev.	①	07.09.07	MCi	Rev.	○			Customer's Approval			
Rev.	②	24.10.07	SRi	Rev.	○			Date			
Rev.	③	18.12.07	SRi	Rev.	○			Signature			
Titel:							Scale 2:1	Drawn	25.01.05	SRi	
SMTU2450N-LF								Checked	18.12.07	HHo	
								Approved	19.12.07	EWe	
							CH-4452 Itingen Switzerland		3.8762.4-3		