

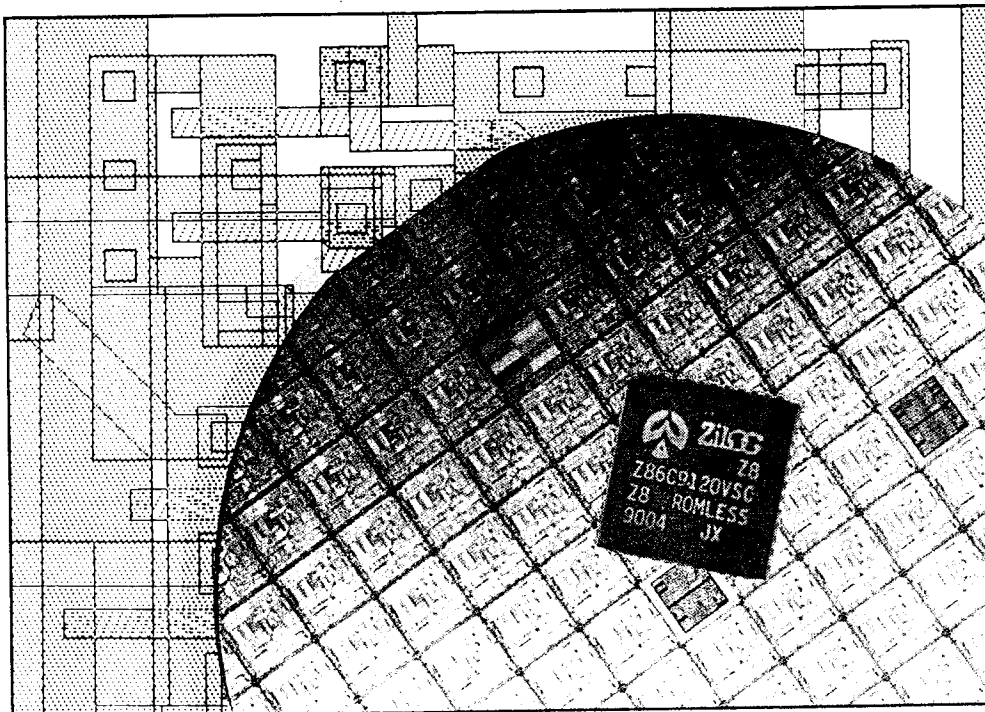

PRODUCT SPECIFICATION

Z86C91

Z8[®] ROMLESS
MICROCONTROLLER



Q2/91



PRODUCT SPECIFICATION

Z86C91

CMOS Z8® ROMLESS MICROCONTROLLER

FEATURES

- 8-bit CMOS microcontroller, 40-pin DIP or 44-pin PLCC and QFP package
- 4.5 to 5.5 Voltage operating range
- Low power Consumption - 275 mW (max) @ 20 MHz
- Fast instruction pointer - 1.0 microsecond @ 12 MHz
- Two standby modes - STOP and HALT
- 32 input/output lines
- Full-Duplex UART
- All digital inputs are TTL levels
- Auto Latches
- ROMless
- 236 bytes of RAM
- Two programmable 8-bit Counter/Timers each with 6-bit programmable prescaler.
- Six vectored, priority interrupts from eight different sources
- Clock speeds 12, 16 and 20 MHz
- On-chip oscillator that accepts a crystal, ceramic resonator, LC or external clock drive.

GENERAL DESCRIPTION

The Z86C91 microcontroller (MCU) introduces a new level of sophistication to single-chip architecture. The Z86C91 is a member of the ROMless Z8 single-chip microcontroller family with 236 bytes of RAM.

The MCU is housed in a 40-pin DIP, 44-pin Leaded Chip-Carrier, or a 44-pin Quad Flat Pack, and is manufactured in CMOS technology. The Z86C91 is a ROMless part and offers the use of external memory which enables this Z8 microcontroller to be used where code flexibility is required.

Zilog's CMOS microcontroller offers fast execution, efficient use of memory, sophisticated interrupts, input/output bit manipulation capabilities, and easy hardware/software system expansion along with low cost and low power consumption.

The Z86C91 architecture is characterized by Zilog's 8-bit microcontroller core. The device offers a flexible I/O scheme, an efficient register and address space structure, multiplexed capabilities between address/data, I/O, and a number of ancillary features that are useful in many industrial and advanced scientific applications.

The device applications demand powerful I/O capabilities. The Z86C91 fulfills this with 24-pin dedicated to input and output. These lines are grouped into four ports. Each port consists of eight lines, and is configurable under software control to provide timing, status signals, serial or parallel I/O with or without handshake, and an address/data bus for interfacing external memory.

There are three basic address spaces available to support this wide range of configuration: Program Memory, Data Memory and 236 General-Purpose Registers.

To unburden the program from coping with the real-time problems such as counting/timing and serial data communication, the Z86C91 offers two on-chip counter/timers with a large number of user selectable modes, and an asynchronous receiver/transmitter (UART-Figure 1).

Note: All Signals with a preceding front slash, "/", are active Low, e.g.: B/W (WORD is active Low); /B/W (BYTE is active Low, only)

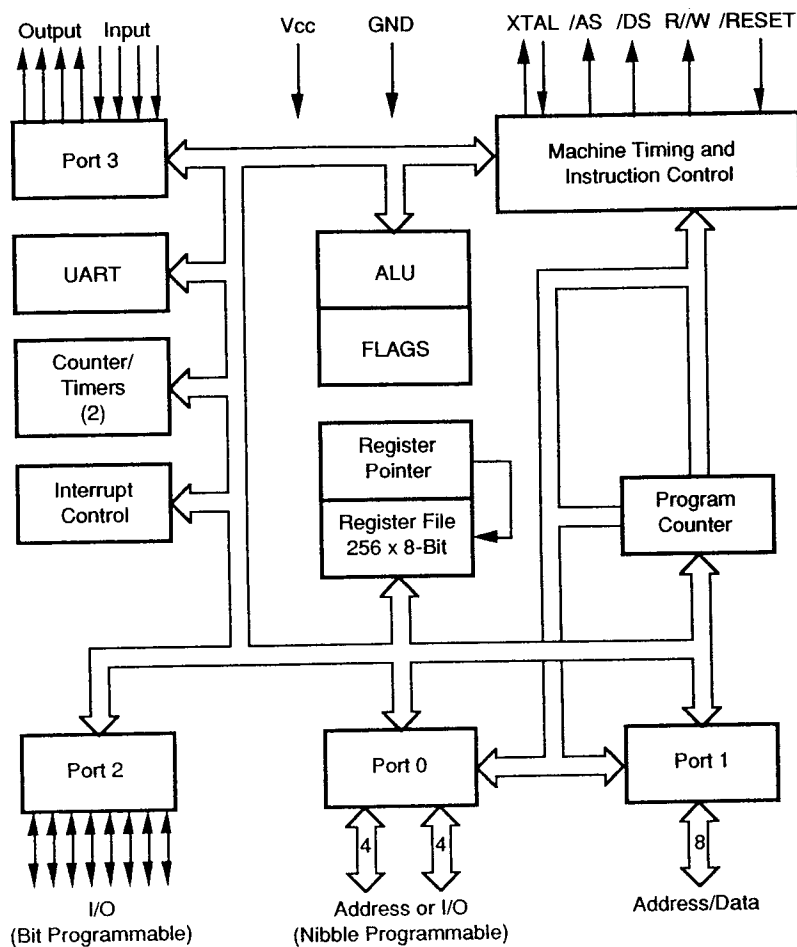

Figure 1. Functional Block Diagram

Pin #
1
2
3
4
5
6
7
8
9
10

PIN DESCRIPTION

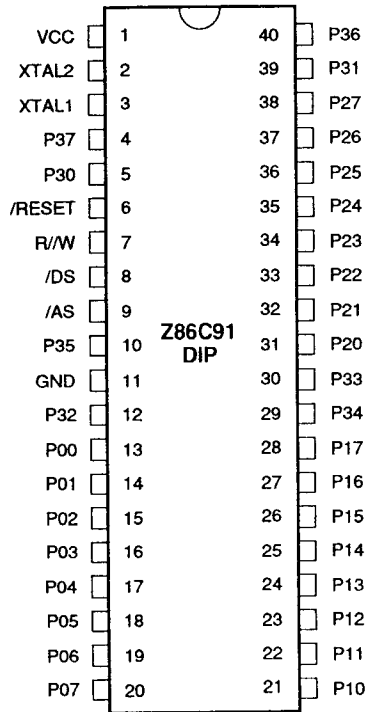

Figure 2. 40-Pin Dual In-Line Plastic Pin Assignments

Table 1. 40-Pin Dual In-Line Plastic Pin Identification

Pin #	Symbol	Function	Direction	Pin #	Symbol	Function	Direction
1	V _{cc}	Power Supply	Input	11	GND	Ground, GND	Input
2	XTAL2	Crystal, Oscillator Clock	Output	12	P32	Port 3 pin 2	Input
3	XTAL1	Crystal, Oscillator Clock	Input	13-20	P00-P07	Port 0 pin 0,1,2,3,4,5,6,7	In/Output
4	P37	Port 3 pin 7	Output	21-28	P10-P17	Port 1 pin 0,1,2,3,4,5,6,7	In/Output
5	P30	Port 3 pin 0	Input	29	P34	Port 3 pin 4	Output
6	/RESET	Reset	Input	30	P33	Port 3 pin 3	Input
7	R/W	Read/Write	Output	31-38	P20-P27	Port 2 pin 0,1,2,3,4,5,6,7	In/Output
8	/DS	Data Strobe	Output	39	P31	Port 3 pin 1	Input
9	/AS	Address Strobe	Output	40	P36	Port 3 pin 6	Output
10	P35	Port 3 pin 5	Output				

PIN DESCRIPTION (Continued)

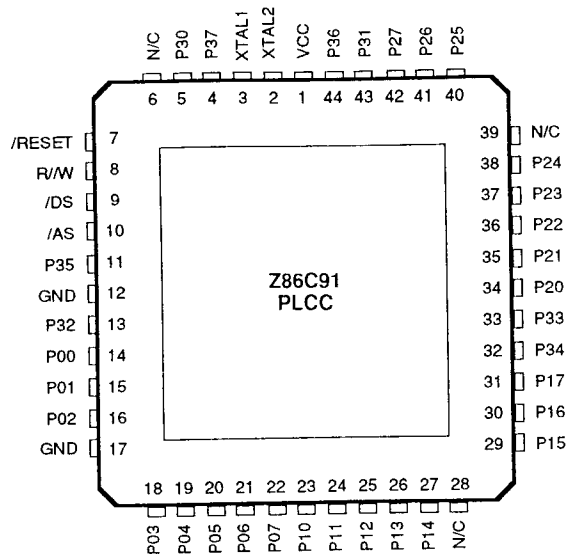

Figure 3. 44-Pin Plastic Leaded Chip Carrier Pin Assignments

Table 2. 44-Pin Plastic Leaded Chip Carrier Pin Identification

Pin #	Symbol	Function	Direction	Pin #	Symbol	Function	Direction
1	V _{cc}	Power Supply	Input	14-16	P00-P02	Port 0 pin 0,1,2	In/Output
2	XTAL2	Crystal, Oscillator Clock	Output	17	GND	Ground	Input
3	XTAL1	Crystal, Oscillator Clock	Input	18-22	P03-P07	Port 0 pin 3,4,5,6,7	In/Output
4	P37	Port 3 pin 7	Output	23-27	P10-P14	Port 1 pin 0,1,2,3,4	In/Output
5	P30	Port 3 pin 0	Input	28	N/C	Not Connected	Input
6	N/C	Not Connected	Input	29-31	P15-P17	Port 1 pin 5,6,7	In/Output
7	/RESET	Reset	Input	32	P34	Port 3 pin 4	Output
8	R/W	Read/Write	Output	33	P33	Port 3 pin 3	Input
9	/DS	Data Strobe	Output	34-38	P20-P24	Port 2 pin 0,1,2,3,4	In/Output
10	/AS	Address Strobe	Output	39	N/C	Not Connected	Input
11	P35	Port 3 pin 5	Output	40-42	P25-P27	Port 2 pin 5,6,7	In/Output
12	GND	Ground	Input	43	P31	Port 3 pin 1	Input
13	P32	Port 3 pin 2	Input	44	P36	Port 3 pin 6	Output

Pin
1-5
6
7-1.
15
16
17-:
22
23-:
26
27
28
29
30

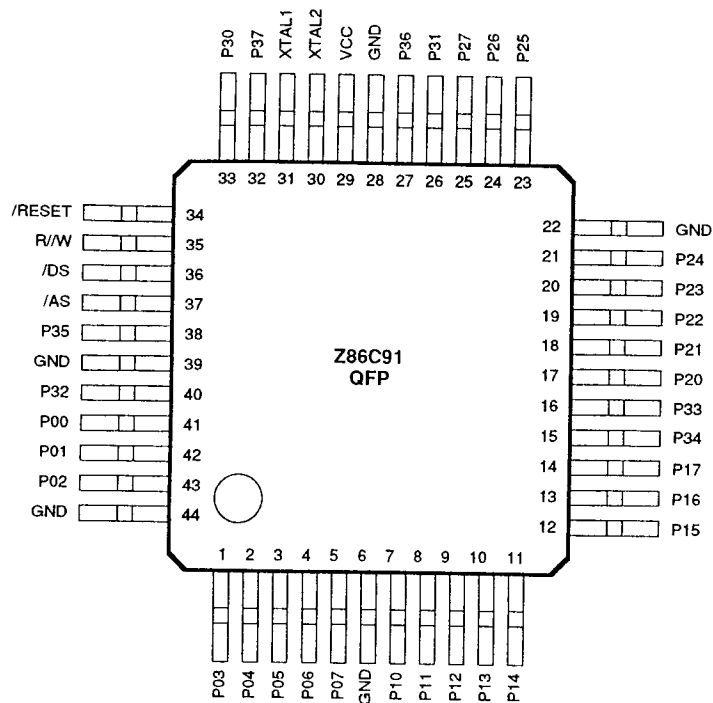

Figure 4. 44-Pin Quad Flat Pack Pin Assignments

Table 3. 44-Pin Quad Flat Pack Pin Identification

Pin #	Symbol	Function	Direction	Pin #	Symbol	Function	Direction
1-5	P03-P07	Port 0 pin 3,4,5,6,7	In/Output	31	XTAL 1	Crystal, Oscillator Clock	Input
6	GND	Ground	Input	32	P37	Port 3 pin 7	Output
7-14	P10-P17	Port 1 pin 0,1,2,3,4,5,6,7	In/Output	33	P30	Port 3 pin 0	Input
15	P34	Port 3 pin 4	Output	34	/RESET	Reset	Input
16	P33	Port 3 pin 3	Input	35	R//W	Read/Write	Output
17-21	P20-P24	Port 2 pin 0,1,2,3,4	In/Output	36	/DS	Data Strobe	Output
22	GND	Ground	Input	37	/AS	Address Strobe	Output
23-25	P25-P27	Port 2 pin 5,6,7	In/Output	38	P35	Port 3 pin 5	Output
26	P31	Port 3 pin 1	Input	39	GND	Ground	Input
27	P36	Port 3 pin 6	Output	40	P32	Port 3 pin 2	Input
28	GND	Ground	Input	41-43	P00-P02	Port 0 pin 0,1,2	In/Output
29	V _{cc}	Power Supply	Input	44	GND	Ground	Input
30	XTAL2	Crystal, Oscillator Clock	Output				

PIN FUNCTIONS

/DS. (output, active Low). Data Strobe is activated once for each external memory transfer. For a READ operation, data must be available prior to the trailing edge of /DS. For WRITE operations, the falling edge of /DS indicates that output data is valid.

/AS. (output, active Low). Address Strobe is pulsed once at the beginning of each machine cycle. Address output is via Port 1 for all external program. Memory address transfers are valid at the trailing edge of /AS. Under program control, /AS can be placed in the high-impedance state along with Ports 0 and 1, Data Strobe, and Read/Write.

XTAL1, XTAL2. *Crystal 1, Crystal 2* (time-based input and output, respectively). These pins connect a parallel-resonant crystal, ceramic resonator, LC, or any external single-phase clock to the on-chip oscillator and buffer.

R/W. (output, write Low). The Read/Write signal is low when the MCU is writing to the external program or data memory.

/RESET. (input, active-Low). To avoid asynchronous and noisy reset problems, the Z86C91 is equipped with a reset filter of four external clocks (4TpC). If the external /RESET signal is less than 4TpC in duration, no reset occurs.

On the 5th clock after the /RESET is detected, an internal RST signal is latched and held for an internal register count of 18 external clocks, or for the duration of the external /RESET, whichever is longer. During the reset cycle, /DS is

held active low while /AS cycles at a rate of 1pC/2. When /RESET is deactivated program execution begins at location 000C. Power-up reset time is held low for 50mS, or until VCC is stable, whichever is longer.

Port 0. P00-P07. Port 0 is an 8-bit, nibble programmable, bidirectional, TTL compatible port. These eight I/O lines are configured under software control as a nibble I/O port, or as an address port for interfacing external memory. When used as an I/O port, Port 0 may be placed under handshake control. In this configuration, Port 3, lines P32 and P35 are used as the handshake control /DAV0 and RDY0 (Data available and Ready). Handshake signal assignment is dictated by the I/O direction of the upper nibble P04-P07. The lower nibble must have the same direction as the upper nibble to be under handshake control.

For external memory references, Port 0 provides Address bits A11-A8 (lower nibble) or A15-A8 (lower and upper nibble) depending on the required address space. If the address range requires 12 bits or less, the upper nibble of Port 0 can be programmed independently as I/O while the lower nibble is used for addressing. If one or both nibbles are needed for I/O operation, they must be configured by writing to the Port 0 Mode register. After a hardware reset, Port 0 lines are defined as address lines A15-A8, and extended timing is set to accommodate slow memory access. The initialization routine includes reconfiguration to eliminate this extended timing mode (Figure 5).

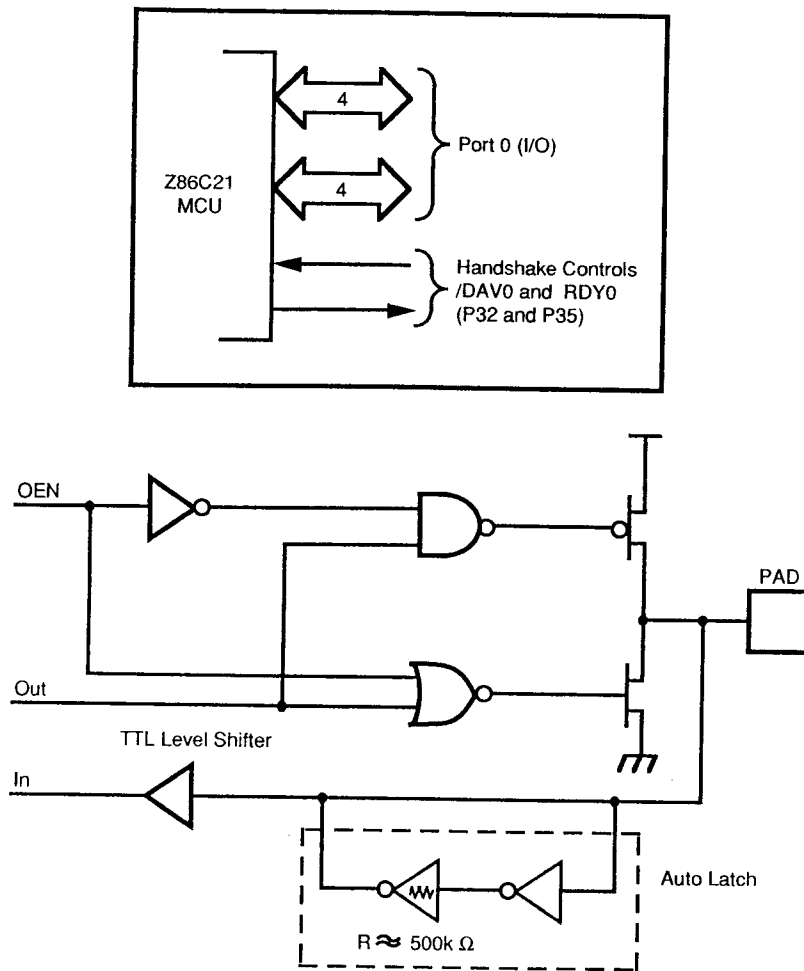

Figure 5. Port 0 Configuration

PIN FUNCTIONS (Continued)

Port 1. (P10-P17). Port 1 is an 8-bit, TTL compatible port. It has multiplexed Address (A7-A0) and Data (D7-D0) ports for interfacing external memory.

If more than 256 external locations are required, Port 0 must output the additional lines.

Port 1 can be placed in a high-impedance state along with Port 0, /AS, /DS and R/W, allowing the MCU to share common resources in multiprocessor and DMA applications. Data transfers are controlled by assigning P33 as a Bus Acknowledge input, and P34 as a Bus request output (Figure 6).

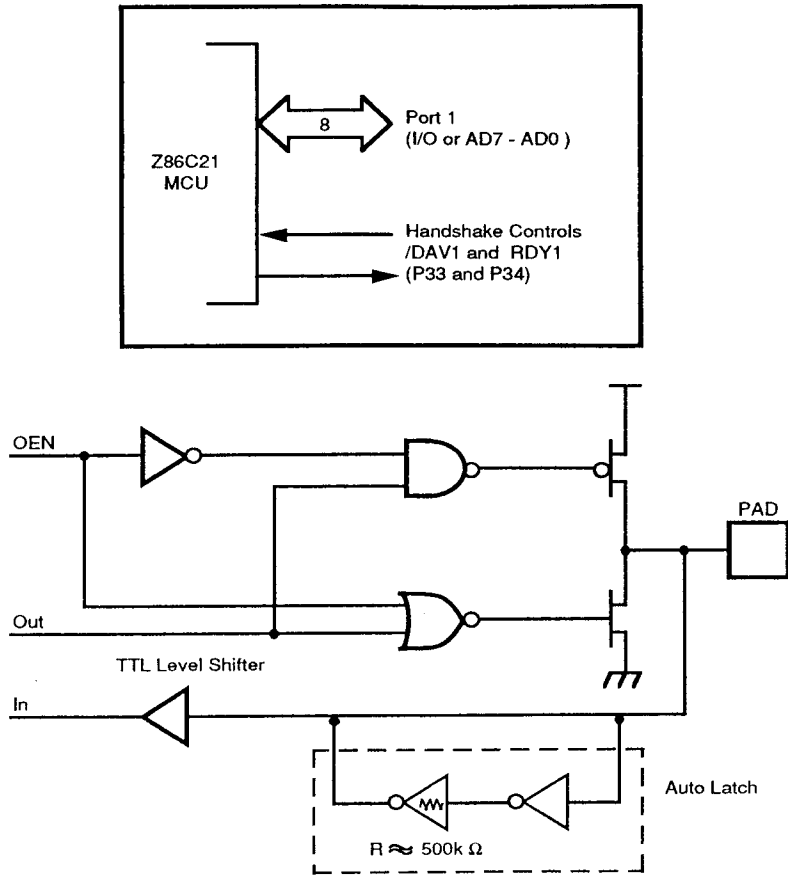

Figure 6. Port 1 Configuration

Port 2. (P20-P27). Port 2 is an 8-bit, bit programmable, bidirectional, TTL compatible port. Each of these eight I/O lines are independently programmed as an input or output or globally as an open-drain output. Port 2 is always available for I/O operation. When used as an I/O port, Port

2 is placed under handshake control. In this configuration, Port 3 lines P31 and P36 are used as the handshake control lines /DAV2 and RDY2. The handshake signal assignment for Port 3 lines P31 and P36 is dictated by the direction (input or output) assigned to P27 (Figure 7).

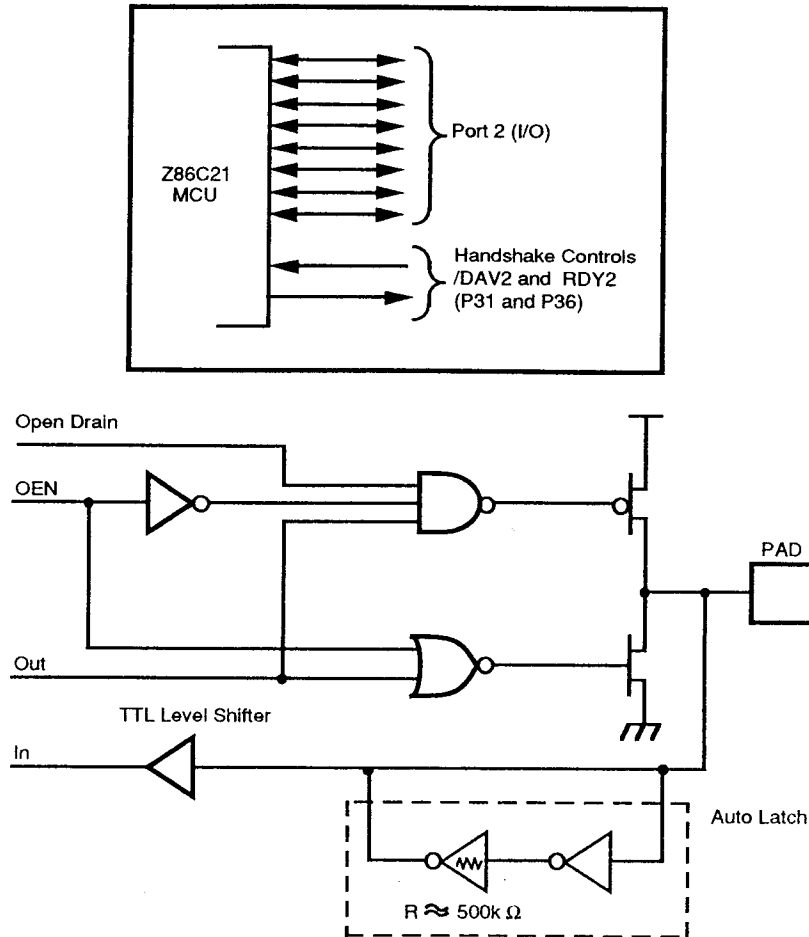

Figure 7. Port 2 Configuration

PIN FUNCTION (Continued)

Port 3. (P30-P37). Port 3 is an 8-bit, TTL compatible four fixed input and four fixed output port. These eight I/O lines have four-fixed (P33-P30) input and four fixed (P37-P34)

output ports. Port 3, when used as serial I/O, are programmed as serial in and serial out, respectively (Figure 8).

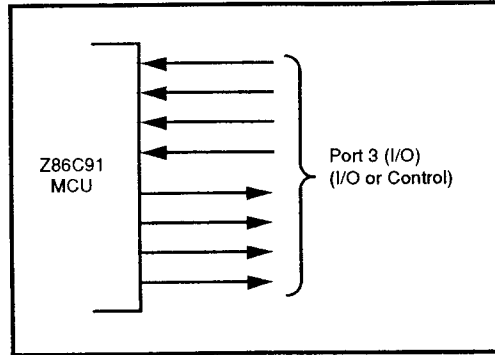

Figure 8. Port 3 Configuration

Port 3 is configured under software control to provide the following control functions: handshake for Ports 0 and 2 (/DAV and RDY); four external interrupt request signals

(IRQ0-IRQ3); timer input and output signals (T_{IN} and T_{OUT}), and Data Memory Select (/DM).

Table 4. Port 3 Pin Assignments

Pin	I/O	CTC1	Int.	P0 HS	P1 HS	P2 HS	UART	Ext
P30	IN		IRQ3				Serial In	
P31	IN	T_{IN}	IRQ2			D/R		
P32	IN		IRQ0	D/R				
P33	IN		IRQ1		D/R			
P34	OUT				R/D			DM
P35	OUT			R/D				
P36	OUT	T_{OUT}				R/D	Serial Out	
P37	OUT							

Notes:
 HS = HANDSHAKE SIGNALS
 D = Data Available
 R = Ready

Port
line:
mitt
Tim

The
bits
ava
mitt
the
the
(IRC

Tr
SI

Tr
SI

Port 3 lines P30 and P37, are programmed as serial I/O lines for full-duplex serial asynchronous receiver/transmitter operation. The bit rate is controlled by the Counter/Timer 0.

The Z86C91 automatically adds a start bit and two stop bits to transmitted data (Figure 9). Odd parity is also available as an option. Eight data bits are always transmitted, regardless of parity selection. If parity is enabled, the eighth bit is the odd parity bit. An interrupt request (IRQ4) is generated on all transmitted characters.

Received data must have a start bit, 8 data bits and at least one stop bit. If parity is on, bit 7 of the received data is replaced by a parity error flag. Received characters generate the IRQ3 interrupt request.

Auto-Latch. The Auto-Latch puts valid CMOS levels on all CMOS inputs that are not externally driven. This reduces excessive supply current flow in the input buffer when it is not driven by any source.

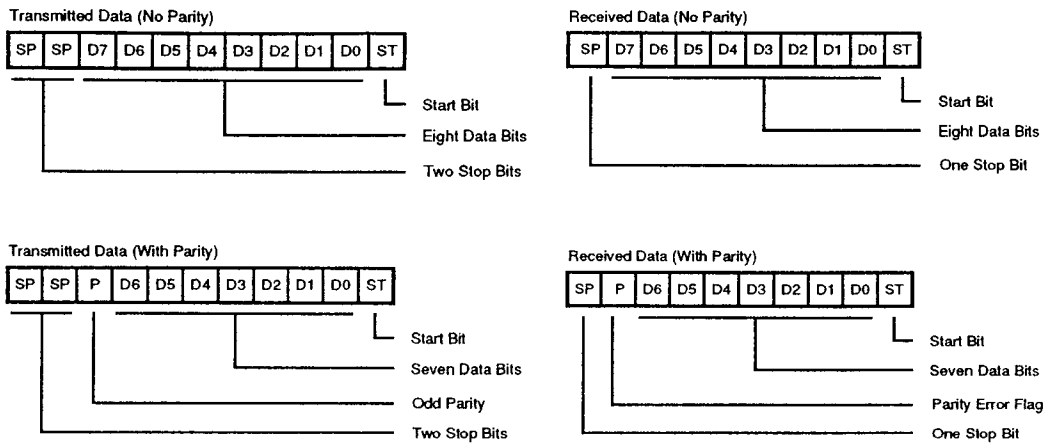

Figure 9. Serial Data Formats

FUNCTIONAL DESCRIPTION

Address Space

The following subsections define Program Memory, Data Memory, Register Files, and Stack Pointers.

Program Memory. The Z86C91 can address up to 64 Kbytes of external program memory (Figure 10). The first 12 bytes of program memory are reserved for the interrupt vectors. These locations contain six 16-bit vectors that correspond to the six available interrupts. Program execution begins at external location 000CH after a reset.

Data Memory (/DM). The Z86C91 addresses up to 64 Kbytes of external data memory space. External data memory is included with, or separated from, the external program memory space. /DM, an optional I/O function that can be programmed to appear on pin P34, is used to distinguish between data and program memory space (Figure 11). The state of the /DM signal is controlled by the type instruction being executed. An LDC opcode references PROGRAM (/DM inactive) memory, and an LDE instruction references DATA (/DM active low) memory.

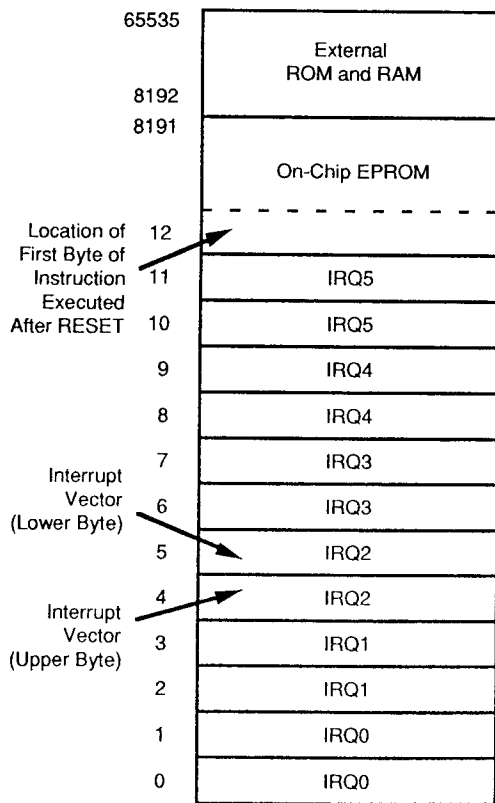

Figure 10. Program Memory Configuration

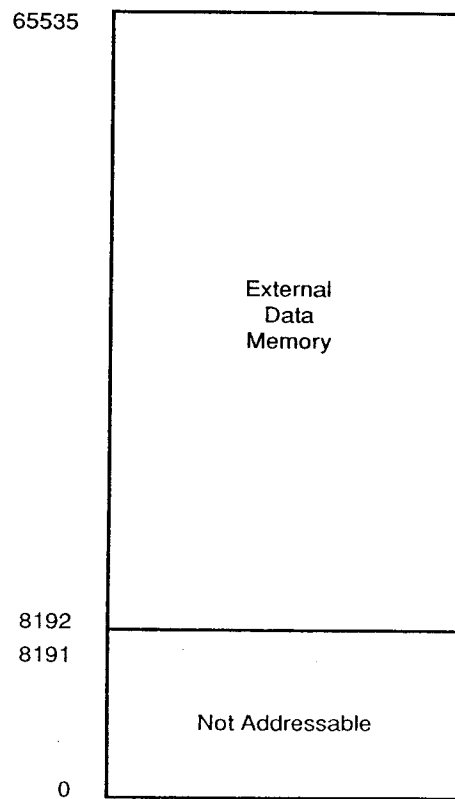

Figure 11. Data Memory Configuration

Register File. The Register File consists of three I/O port registers, 236 general-purpose registers and 16 control and status registers (Figure 12). The instructions can access registers directly or indirectly via an 8-bit address field. The Z86C91 also allows short 4-bit register addressing using the Register Pointer (Figure 13). In the 4-bit mode, the Register File is divided into 16 working register

groups, each occupying 16 continuous locations. The Register Pointer addresses the starting location of the active working-register group.

Note: Register Bank E0-EF is only accessed through working register and indirect addressing modes.

LOCATION		IDENTIFIERS	
255	Stack Pointer (Bits 7-0)	SPL	
254	Stack Pointer (Bits 15-8)	SPH	
253	Register Pointer	RP	
252	Program Control Flags	FLAGS	
251	Interrupt Mask Register	IMR	
250	Interrupt Request Register	IRQ	
249	Interrupt Priority Register	IPR	
248	Ports 0-1 Mode	P01M	
247	Port 3 Mode	P3M	
246	Port 2 Mode	P2M	
245	T0 Prescaler	PRE0	
244	Timer/Counter 0	T0	
243	T1 Prescaler	PRE1	
242	Timer/Counter 1	T1	
241	Timer Mode	TMR	
240	Serial I/O	SIO	
239	General-Purpose Registers		
4			
3		Port 3	P3
2		Port 2	P2
1			Reserved
0	Port 0	P0	

Figure 12. Register File

FUNCTIONAL DESCRIPTION (Continued)

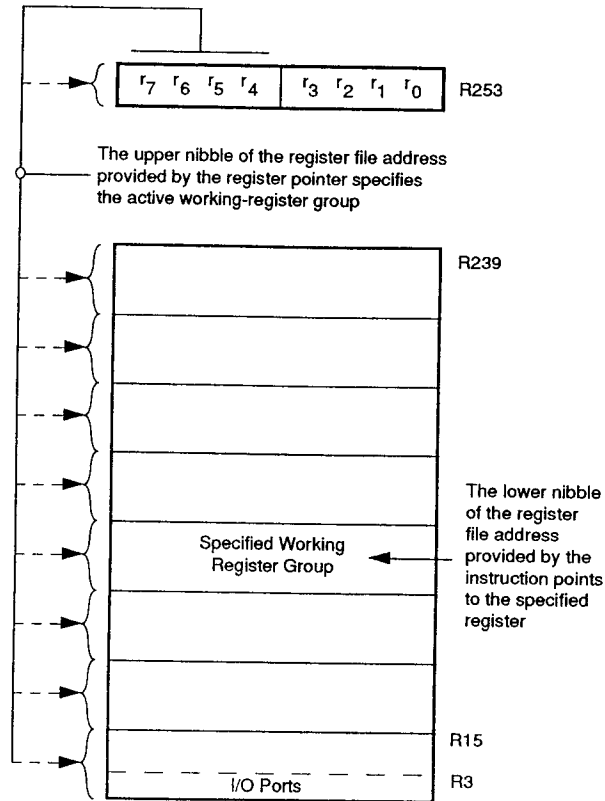

Figure 13. Register Pointer

Stack. The Z86C91 has a 16-bit Stack Pointer (R254-R255) used for external stack that resides anywhere in the data memory. An 8-bit Stack Pointer (R255) is used for the internal stack that resides within the 236 general-purpose

registers (R4-R239). The high byte of the Stack Pointer (SPH-Bit 8-15) is used as a general purpose register when using internal stack only.

Counter/Timers. There are two 8-bit programmable counter/timers (T0-T1), each driven by its own 6-bit programmable prescaler. The T1 prescaler is driven by internal or external clock sources; however, the T0 prescaler is driven by the internal clock only (Figure 14).

The 6-bit prescalers divide the input frequency of the clock source by any integer number from 1 to 64. Each prescaler drives its counter, which decrements the value (1 to 256) that has been loaded into the counter. When both the counter and prescaler reach the end of the count, a timer interrupt request, IRQ4 (T0) or IRQ5 (T1), is generated.

The counter can be programmed to start, stop, restart to continue, or restart from the initial value. The counters can

also be programmed to stop upon reaching zero (single pass mode) or to automatically reload the initial value and continue counting (modulo-n continuous mode).

The counter, but not the prescalers, are read at any time without disturbing their value or count mode. The clock source for T1 is user-definable and can be either the internal microprocessor clock divided by four, or an external signal input via Port 3. The Timer Mode register configures the external timer input (P31) as an external clock, a trigger input that can be retriggerable or non-retriggerable, or as a gate input for the internal clock. Port 3 line P36 also serves as a timer output (T_{OUT}) through which T0, T1 or sub the internal clock is output. The counter/timers are cascaded by connecting the T0 output to the input of T1

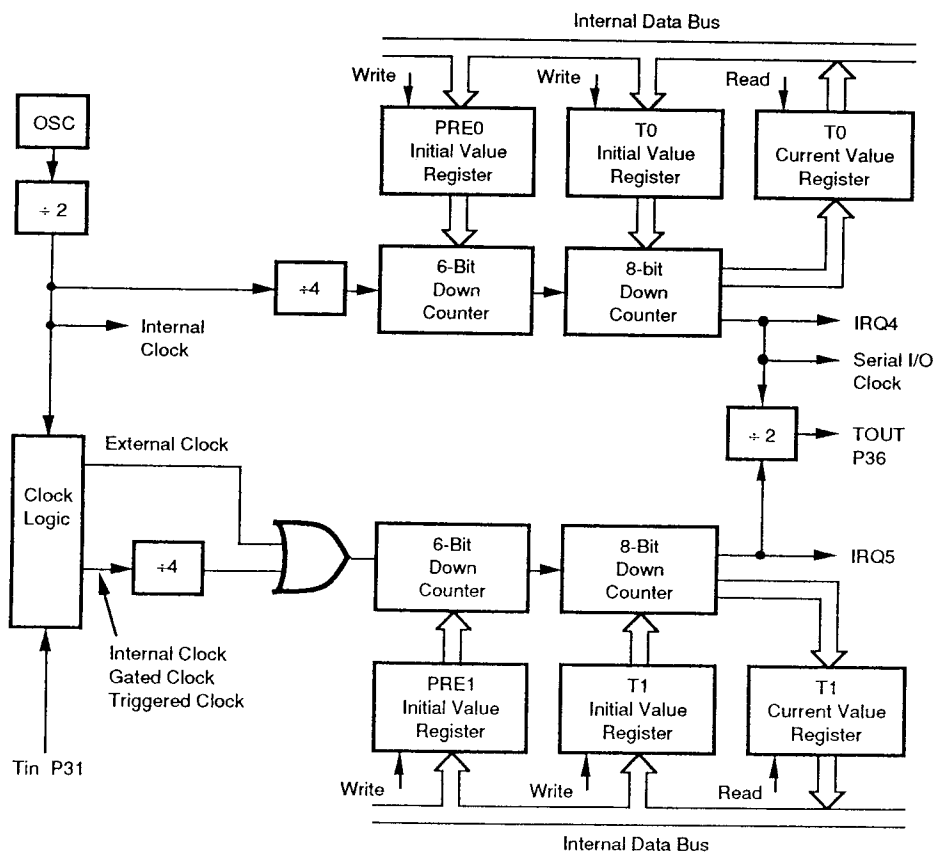

Figure 14. Counter/Timers Block Diagram

FUNCTIONAL DESCRIPTION (Continued)

Interrupts. The Z86C91 has six different interrupts from eight different sources. The interrupts are maskable and prioritized. The eight sources are divided as follow: four sources are claimed by Port 3 lines P30-P33, one in Serial Out, one in Serial In, and two in the counter/timers (Figure 15). The Interrupt Mask Register globally or individually enables or disables the six interrupt requests. When more than one interrupt is pending, priorities are resolved by a programmable priority encoder that is controlled by the Interrupt Priority register.

All Z86C91 interrupts are vectored through locations in the program memory. When an interrupt machine cycle is activated, an interrupt request is granted. Thus, this disables all of the subsequent interrupts, save the Program Counter and Status Flags, and then branches to the program memory vector location reserved for that interrupt. This memory location and the next byte contain the 16-bit address of the interrupt service routine for that particular interrupt request.

To accommodate polled interrupt systems, interrupt inputs are masked and the Interrupt Request register is polled to determine which of the interrupt requests need service. Software initiated interrupts are supported by setting the appropriate bit in the Interrupt Request register (IRQ).

Internal interrupt requests are sampled on the falling edge of the last cycle of every instruction, and the interrupt request must be valid 5TpC before the falling edge of the last clock cycle of the currently executing instruction.

When the device samples a valid interrupt request, the next 48 (external) clock cycles are used to prioritize the interrupt, and push the two PC bytes and the FLAG register on the stack. The following nine cycles are used to fetch the interrupt vector from external memory. The first byte of the interrupt service routine is fetched beginning on the 58th TpC cycle following the internal sample point, which corresponds to the 63rd TpC cycle following the external interrupt sample point.

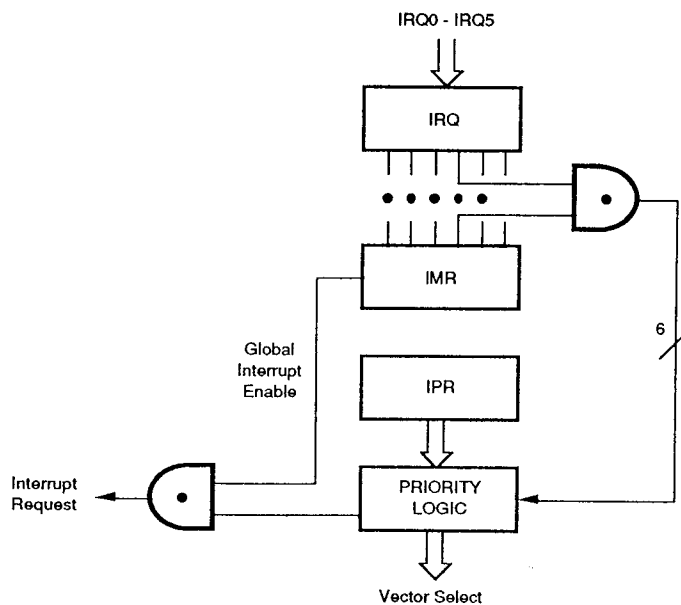

Figure 15. Interrupt Block Diagram

Clock. The Z86C91 on-chip oscillator has a high-gain, parallel-resonant amplifier for connection to a crystal, LC, ceramic resonator, or any suitable external clock source (XTAL1=Input, XTAL2=Output). The crystal should be AT cut, 1 MHz to 20 MHz max, and series resistance (RS) less

than or equal to 100 Ohms. The crystal should be connected across XTAL1 and XTAL2 using the recommended capacitors ($10\text{ pF} < C_L < 300\text{ pF}$) from each pin to ground (Figure 16).

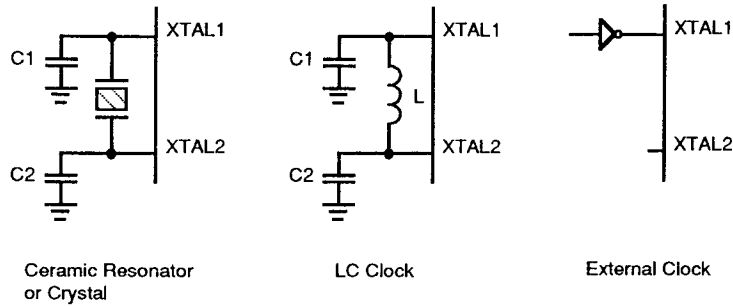

Figure 16. Oscillator Configuration

HALT. Turns off the internal CPU clock but not the XTAL oscillation. The counter/timers and the external interrupts IRQ0, IRQ1, IRQ2 and IRQ3 remain active. The devices are recovered by interrupts, either externally or internally generated.

STOP. This instruction turns off the internal clock and external crystal oscillation and reduces the standby current to 10 microamperes or less. The Stop mode is terminated by a reset, which cause the processor to restart the application program at address 000CH.

In order to enter STOP (or HALT) mode, it is necessary to first flush the instruction pipeline to avoid suspending execution in mid-instruction. To do this, the user must execute a NOP (opcode=OFFH) immediately before the appropriate sleep instruction, i.e.:

```

FF NOP ; clear the pipeline
6F STOP ; enter STOP mode
or
FF NOP ; clear the pipeline
7F HALT ; enter HALT mode

```

ABSOLUTE MAXIMUM RATINGS

Symbol	Description	Min	Max	Units
V_{CC}	Supply Voltage*	-0.3	+7.0	V
T_{STG}	Storage Temp	-65	+150	C
T_A	Oper Ambient Temp		†	C

Notes:

* Voltages on all pins with respect to GND.

† See Ordering Information

Stress greater than those listed under Absolute Maximum Ratings may cause permanent damage to the device. This is a stress rating only; operation of the device at any condition above those indicated in the operational sections of these specifications is not implied. Exposure to absolute maximum rating conditions for an extended period may affect device reliability.

STANDARD TEST CONDITIONS

The characteristics listed below apply for standard test conditions as noted. All voltages are referenced to GND. Positive current flows into the referenced pin (Figure 17).

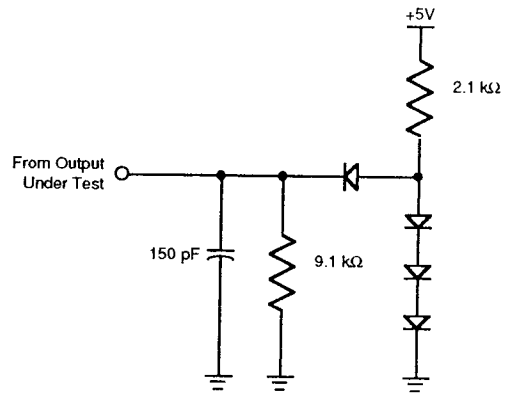

Figure 17. Test Load Diagram

DC CHARACTERISTICS

Sym	Parameter	$T_A = 0^\circ\text{C}$ to 70°C		$T_A = -40^\circ\text{C}$ to 105°C		Typical at 25°C	Units	Conditions
		Min	Max	Min	Max			
	Max Input Voltage		7	7			V	$I_{IN} = 250\mu\text{A}$
V_{OH}	Clock Input High Voltage	3.8	V_{CC}	3.8	V_{CC}		V	Driven by External Clock Generator
V_{OL}	Clock Input Low Voltage	-0.03	0.8	-0.03	0.8		V	Driven by External Clock Generator
V_{IH}	Input High Voltage	2.0	V_{CC}	2.0	V_{CC}		V	
V_{IL}	Input Low Voltage	-0.3	0.8	-0.3	0.8		V	
V_{OH}	Output High Voltage	2.4		2.4			V	$I_{OH} = -2.0\text{ mA}$
V_{OH}	Output High Voltage	$V_{CC} - 100\text{mV}$		$V_{CC} - 100\text{mV}$			V	$I_{OH} = -100\mu\text{A}$
V_{OL}	Output Low Voltage		0.4		0.4		V	$I_{OH} = +2.0\text{ mA}$
V_{RH}	Reset Input High Voltage	3.8	V_{CC}	3.8	V_{CC}		V	
V_{RL}	Reset Input Low Voltage	-0.03	0.8	-0.03	0.8		V	
I_{IL}	Input Leakage	-2	2	-2	2		μA	Test at 0V , V_{CC}
I_{OL}	Output Leakage	-2	2	-2	2		μA	Test at 0V , V_{CC}
I_{BR}	Reset Input Current		-80		-80		μA	$V_{RL} = 0\text{V}$
I_{CC}	Supply Current		30		30	20	mA	@ 12 MHz [1]
			35		35	24	mA	@ 16 MHz [1]
			50		50		mA	@ 20 MHz [1]
I_{CC1}	Standby Current		6.5		6.5	4	mA	HALT Mode $V_{IN} = 0\text{V}$, V_{CC} @ 12 MHz [1]
			7		7	4.5	mA	HALT Mode $V_{IN} = 0\text{V}$, V_{CC} @ 16 MHz [1]
			8.5		8.5		mA	HALT Mode $V_{IN} = 0\text{V}$, V_{CC} @ 20 MHz [1]
I_{CC2}	Standby Current		10		10	1	μA	STOP Mode $V_{IN} = 0\text{V}$, V_{CC} [1]
I_{ALL}	Auto Latch Low Current	-10	10	-14	14	5	μA	

Note:

[1] All inputs driven to 0V , V_{CC} and outputs floating.

AC CHARACTERISTICS

External I/O or Memory Read/Write Timing Diagram

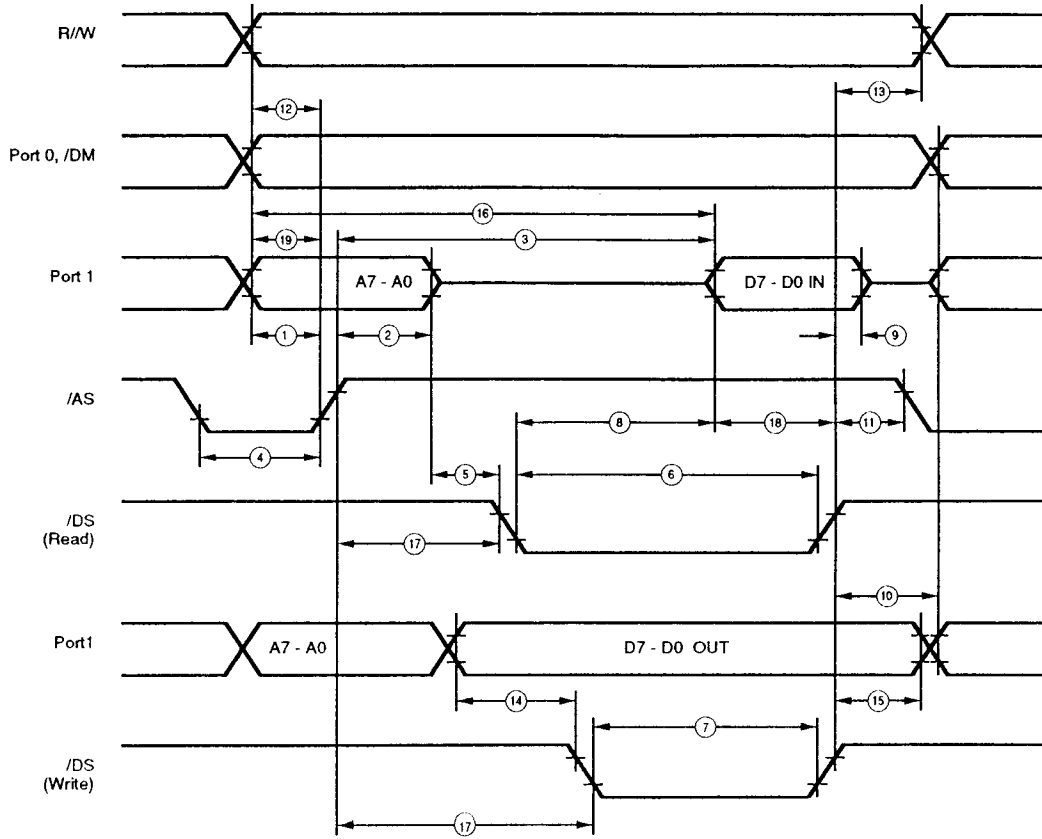

Figure 18. External I/O or Memory Read/Write Timing

A
E
N
1
2
3
4
5
6
7
8
9
10
11
12
13
14
15
16
17
18
19

AC CHARACTERISTICS

External I/O or Memory Read or Write Timing Table

No	Symbol	Parameter	$T_A = 0^\circ\text{C to } 70^\circ\text{C}$						Units	Notes	
			12 MHz		16 MHz		20 MHz				
			Min	Max	Min	Max	Min	Max			
			$T_A = -40^\circ\text{C to } 105^\circ\text{C}$								
			12 MHz		16 MHz		20 MHz				
			Min	Max	Min	Max	Min	Max			
1	TdA(AS)	Address Valid to /AS Rise Delay	35	25	20	35	25	20	ns	[2,3]	
2	TdAS(A)	/AS Rise to Address Float Delay	45	35	25	45	35	25	ns	[2,3]	
3	TdAS(DR)	/AS Rise to Read Data Req'd Valid		250	180	150	250	180	150	ns	[1,2,3]
4	TwAS	/AS Low Width	55	40	30	55	40	30	ns	[2,3]	
5	TdAZ(DS)	Address Float to /DS Fall	0	0	0	0	0	0	ns		
6	TwDSR	/DS (Read) Low Width	185	135	105	185	135	105	ns	[1,2,3]	
7	TwDSW	/DS (Write) Low Width	110	80	65	110	80	65	ns	[1,2,3]	
8	TdDSR(DR)	/DS Fall to Read Data Req'd Valid		130	75	55	130	75	55	ns	[1,2,3]
9	ThDR(DS)	Read Data to /DS Rise Hold Time	0	0	0	0	0	0	ns	[2,3]	
10	TdDS(A)	/DS Rise to Address Active Delay	65	50	40	65	50	40	ns	[2,3]	
11	TdDS(AS)	/DS Rise to /AS Fall Delay	45	35	25	45	35	25	ns	[2,3]	
12	TdR/W(AS)	R/W Valid to /AS Rise Delay	30	25	20	33	25	20	ns	[2,3]	
13	TdDS(R/W)	/DS Rise to R/W Not Valid	50	35	25	50	35	25	ns	[2,3]	
14	TdDW(DSW)	Write Data Valid to /DS Fall (Write) Delay	35	25	20	35	25	20	ns	[2,3]	
15	TdDS(DW)	/DS Rise to Write Data Not Valid Delay	55	35	25	55	35	25	ns	[2,3]	
16	TdA(DR)	Address Valid to Read Data Req'd Valid	310	230	180	310	230	180	ns	[1,2,3]	
17	TdAS(DS)	/AS Rise to /DS Fall Delay	65	45	35	65	45	35	ns	[2,3]	
18	TdDI(DS)	Data Input Setup to /DS Rise	75	60	50	75	60	50	ns	[1,2,3]	
19	TdDM(AS)	/DM Valid to /AS Rise Delay	50	30	20	50	30	20	ns	[2,3]	

Notes:

- [1] When using extended memory timing add 2 TpC.
 [2] Timing numbers given are for minimum TpC.
 [3] See clock cycle dependent characteristics table.

Standard Test Load

All timing references use 2.0V for a logic 1 and 0.8V for a logic 0.

Clock Dependent Formulas

Number	Symbol	Equation
1	TdA(AS)	$0.40T_{pC} + 0.32$
2	TdAS(A)	$0.59T_{pC} - 3.25$
3	TdAS(DR)	$2.38T_{pC} + 6.14$
4	TwAS	$0.66T_{pC} - 1.65$
6	TwDSR	$2.33T_{pC} - 10.56$
7	TwDSW	$1.27T_{pC} + 1.67$
8	TdDSR(DR)	$1.97T_{pC} - 42.5$
10	TdDS(A)	$0.8T_{pC}$
11	TdDS(AS)	$0.59T_{pC} - 3.14$
12	TdR/W(AS)	$0.4T_{pC}$
13	TdDS(R/W)	$0.8T_{pC} - 15$
14	TdDW(DSW)	$0.4T_{pC}$
15	TdDS(DW)	$0.88T_{pC} - 19$
16	TdA(DR)	$4T_{pC} - 20$
17	TdAS(DS)	$0.91T_{pC} - 10.7$
18	TsDI(DS)	$0.8T_{pC} - 10$
19	TdDM(AS)	$0.9T_{pC} - 26.3$

AC CHARACTERISTICS
Additional Timing Diagram

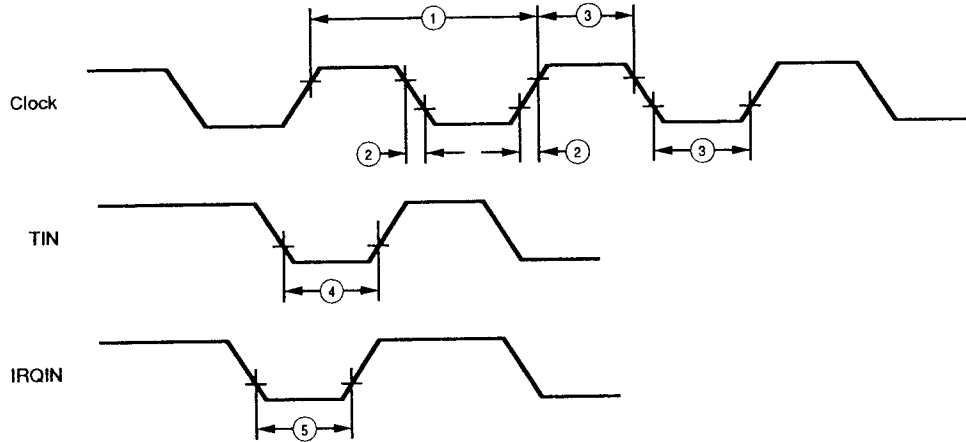

Figure 19. Additional Timing

AC CHARACTERISTICS
Additional Timing Table

No	Symbol	Parameter	$T_A = 0^\circ\text{C to } 70^\circ\text{C}$						$T_A = -40^\circ\text{C to } 105^\circ\text{C}$						Units	Notes
			12 MHz		16 MHz		20 MHz		12 MHz		16 MHz		20 MHz			
			Min	Max	Min	Max	Min	Max	Min	Max	Min	Max	Min	Max		
1	TpC	Input Clock Period	83	1000	62.5	1000	50	1000	83	1000	62.5	1000	50	1000	ns	[1]
2	TrC,TfC	Clock Input Rise & Fall Times		15		10		10		15		10		10	ns	[1]
3	TwC	Input Clock Width	35		25		15		35		25		15		ns	[1]
4	TwTinL	Timer Input Low Width	75		75		75		75		75		75		ns	[2]
5	TwTinH	Timer Input High Width	3TpC		3TpC		3TpC		3TpC		3TpC		3TpC			[2]
6	TpTin	Timer Input Period	8TpC		8TpC		8TpC		8TpC		8TpC		8TpC			[2]
7	TrTin,TfTin	Timer Input Rise & Fall Times	100		100		100		100		100		100		ns	[2]
8A	TwIL	Interrupt Request Input Low Times	70		70		70		70		70		70		ns	[2,4]
8B	TwLL	Interrupt Request Input Low Times	3TpC		3TpC		3TpC		3TpC		3TpC		3TpC			[2,5]
9	TwIH	Interrupt Request Input High Times	3TpC		3TpC		3TpC		3TpC		3TpC		3TpC			[2,3]

Notes:

- [1] Clock timing references use 3.8V for a logic 1 and 0.8V for a logic 0.
- [2] Timing references use 2.0V for a logic 1 and 0.8V for a logic 0.
- [3] Interrupt references request via Port 3.
- [4] Interrupt request via Port 3 (P31-P33).
- [5] Interrupt request via Port 30.

AC CHARACTERISTICS

Handshake Timing Diagrams

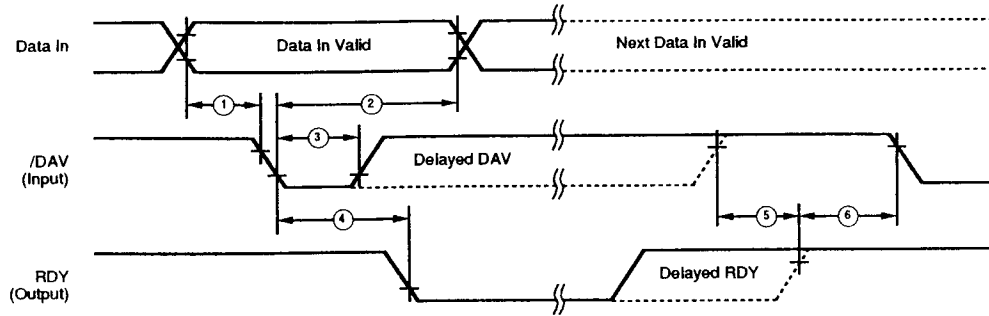

Figure 20. Input Handshake Timing

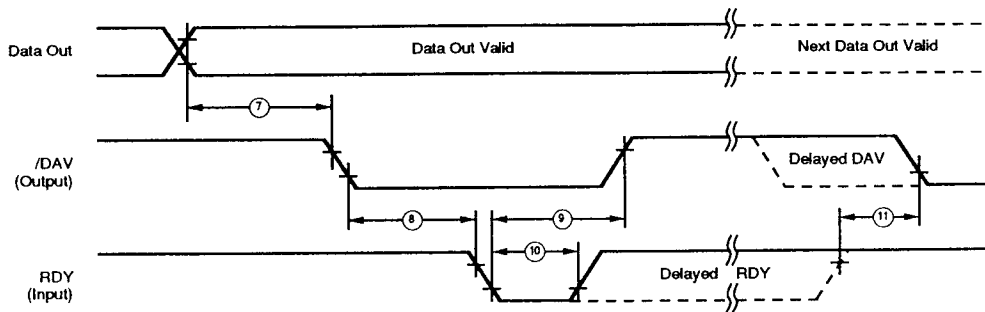

Figure 21. Output Handshake Timing

AC CHARACTERISTICS

Handshake Timing Table

No	Symbol	Parameter	$T_A = 0^\circ\text{C TO } 70^\circ\text{C}$		$T_A = -40^\circ\text{C TO } 105^\circ\text{C}$		Notes (Data Direction)
			12, 16, and 20 MHz Min	Max	12, 16, and 20 MHz Min	Max	
1	TsDI(DAV)	Data In Setup Time	0		0		IN
2	ThDI(DAV)	Data In Hold Time	145		145		IN
3	TwDAV	Data Available Width	110		110		IN
4	TdDAVI(RDY)	DAV fall to RDY fall Delay		115		115	IN
5	TdDAVI(DAV)	DAV rise to RDY rise Delay		115		115	IN
6	TdDO(DAV)	RDY rise to DAV fall Delay	0		0		IN
7	TcLDAV0(RDY)	Data Out to DAV fall Delay		TpC		TpC	OUT
8	TcLDAV0(RDY)	DAV fall to RDY fall Delay	0		0		OUT
9	TdRDY0(DAV)	RDY fall to DAV rise Delay		115		115	OUT
10	TwRDY	RDY Width	110		110		OUT
11	TdRDY0d(DAV)	RDY rise to DAV fall Delay		115		115	OUT

Z8 CONTROL REGISTER DIAGRAMS

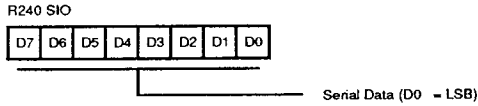

Figure 22. Serial I/O Register (F0H: Read/Write)

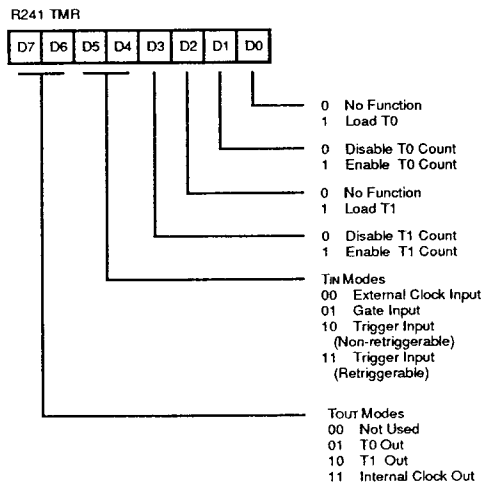

Figure 23. Timer Mode Register (F1H: Read/Write)

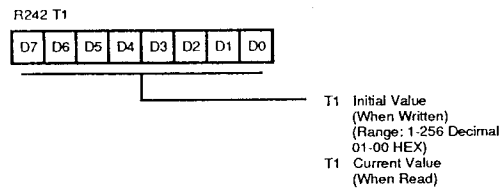

Figure 24. Counter/Timer 1 Register (F2H: Read/Write)

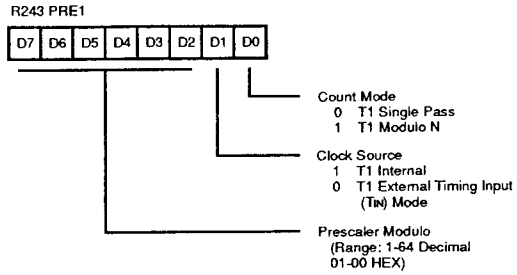

Figure 25. Prescaler 1 Register (F3H: Write Only)

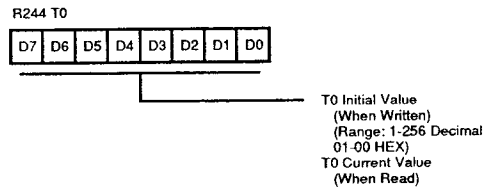

Figure 26. Counter/Timer 0 Register (F4H: Read/Write)

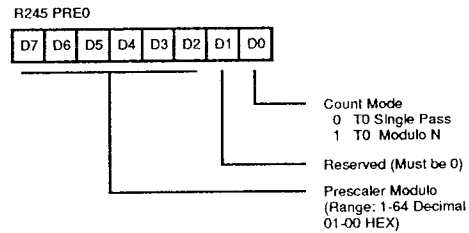
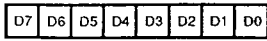

Figure 27. Prescaler 0 Register (F5H: Write Only)

R246 P2M



P2₀ - P2₇ I/O Definition
 0 Defines Bit as Output
 1 Defines Bit as Input

Figure 28. Port 2 Mode Register (F6H: Write Only)

R247 P3M

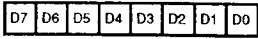

0 Port 2 Open Drain
 1 Port 2 Push-pull
 Reserved
 0 P3₂ = Input
 P3₅ = Output
 1 P3₂ = /DAV0/RDY0
 P3₅ = RDY0/DAV0
 00 P3₃ = Input
 P3₄ = Output
 01 P3₃ = Input
 10 P3₄ = /DM
 11 P3₃ = /DAV1/RDY1
 P3₄ = RDY1/DAV1
 0 P3₁ = Input (TIN)
 P3₆ = Output (TOUT)
 1 P3₁ = /DAV2/RDY2
 P3₆ = RDY2/DAV2
 0 P3₀ = Input
 P3₇ = Output
 1 P3₀ = Serial In
 P3₇ = Serial Out
 0 Parity Off
 1 Parity On

Figure 29. Port 3 Mode Register (F7H: Write Only)

R248 P01M

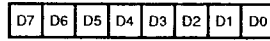

P0₃ - P0₀ Mode
 00 Output
 01 Input
 1X A11 - A8
 Stack Selection
 0 External
 1 Internal
 Reserved (must be zero)
 External Memory Timing
 0 Normal
 1 Extended
 P0₇ - P0₄ Mode
 00 Output
 01 Input
 1X A15 - A12

Figure 30. Port 0 and 1 Mode Register (F8H: Write Only)

R249 IPR

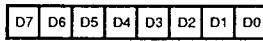

Interrupt Group Priority
 Reserved = 000
 C > A > B = 001
 A > B > C = 010
 A > C > B = 011
 B > C > A = 100
 C > B > A = 101
 B > A > C = 110
 Reserved = 111
 IRQ1, IRQ4 Priority (Group C)
 0 IRQ1 > IRQ4
 1 IRQ4 > IRQ1
 IRQ0, IRQ2 Priority (Group B)
 0 IRQ2 > IRQ0
 1 IRQ0 > IRQ2
 IRQ3, IRQ5 Priority (Group A)
 0 IRQ5 > IRQ3
 1 IRQ3 > IRQ5
 Reserved

Figure 31. Interrupt Priority Register (F9H: Write Only)

Z8 CONTROL REGISTER DIAGRAMS (Continued)

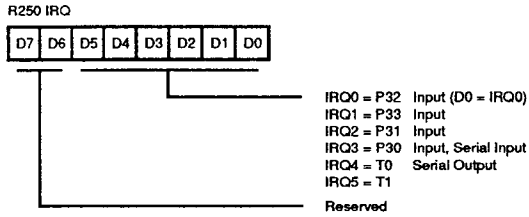

Figure 32. Interrupt Request Register (FAH: Read/Write)

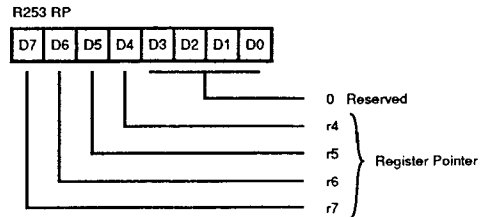

Figure 35. Register Pointer Register (FDH: Read/Write)

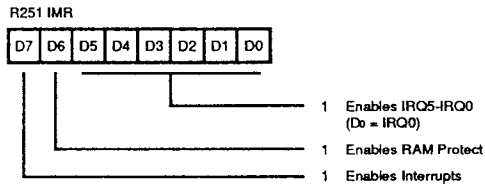

Figure 33. Interrupt Mask Register (FBH: Read/Write)

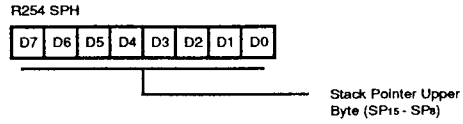

Figure 36. Stack Pointer Register (FEH: Read/Write)

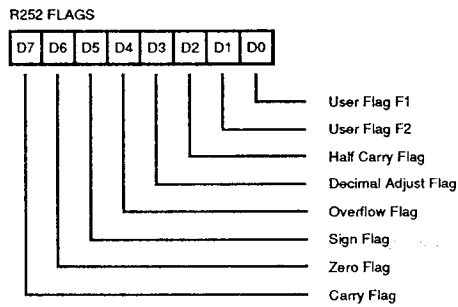

Figure 34. Flag Register (FCH: Read/Write)

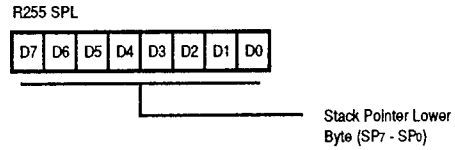

Figure 37. Stack Pointer Register (FFH: Read/Write)

INSTRUCTION SET NOTATION

Addressing Modes. The following notation is used to describe the addressing modes and instruction operations as shown in the instruction summary.

Symbol	Meaning
IRR	Indirect register pair or indirect working-register pair address
Irr	Indirect working-register pair only
X	Indexed address
DA	Direct address
RA	Relative address
IM	Immediate
R	Register or working-register address
r	Working-register address only
IR	Indirect-register or indirect working-register address
Ir	Indirect working-register address only
RR	Register pair or working register pair address

Flags. Control register (R252) contains the following six flags:

Symbol	Meaning
C	Carry flag
Z	Zero flag
S	Sign flag
V	Overflow flag
D	Decimal-adjust flag
H	Half-carry flag

Affected flages are indicated by:

0	Clear to zero
1	Set to one
*	Set to clear according to operation
-	Unaffected
x	Undefined

Symbols. The following symbols are used in describing the instruction set.

Symbol	Meaning
dst	Destination location or contents
src	Source location or contents
cc	Condition code
@	Indirect address prefix
SP	Stack Pointer
PC	Program Counter
FLAGS	Flag register (Control Register 252)
RP	Register Pointer (R253)
IMR	Interrupt mask register (R251)

CONDITION CODES

Value	Mnemonic	Meaning	Flags Set
1000		Always True	
0111	C	Carry	C = 1
1111	NC	No Carry	C = 0
0110	Z	Zero	Z = 1
1110	NZ	Not Zero	Z = 0
1101	PL	Plus	S = 0
0101	MI	Minus	S = 1
0100	OV	Overflow	V = 1
1100	NOV	No Overflow	V = 0
0110	EQ	Equal	Z = 1
1110	NE	Not Equal	Z = 0
1001	GE	Greater Than or Equal	(S XOR V) = 0
0001	LT	Less than	(S XOR V) = 1
1010	GT	Greater Than	[Z OR (S XOR V)] = 0
0010	LE	Less Than or Equal	[Z OR (S XOR V)] = 1
1111	UGE	Unsigned Greater Than or Equal	C = 0
0111	ULT	Unsigned Less Than	C = 1
1011	UGT	Unsigned Greater Than	(C = 0 AND Z = 0) = 1
0011	ULE	Unsigned Less Than or Equal	(C OR Z) = 1
0000		Never True	

INSTRUCTION FORMATS



One-Byte Instructions

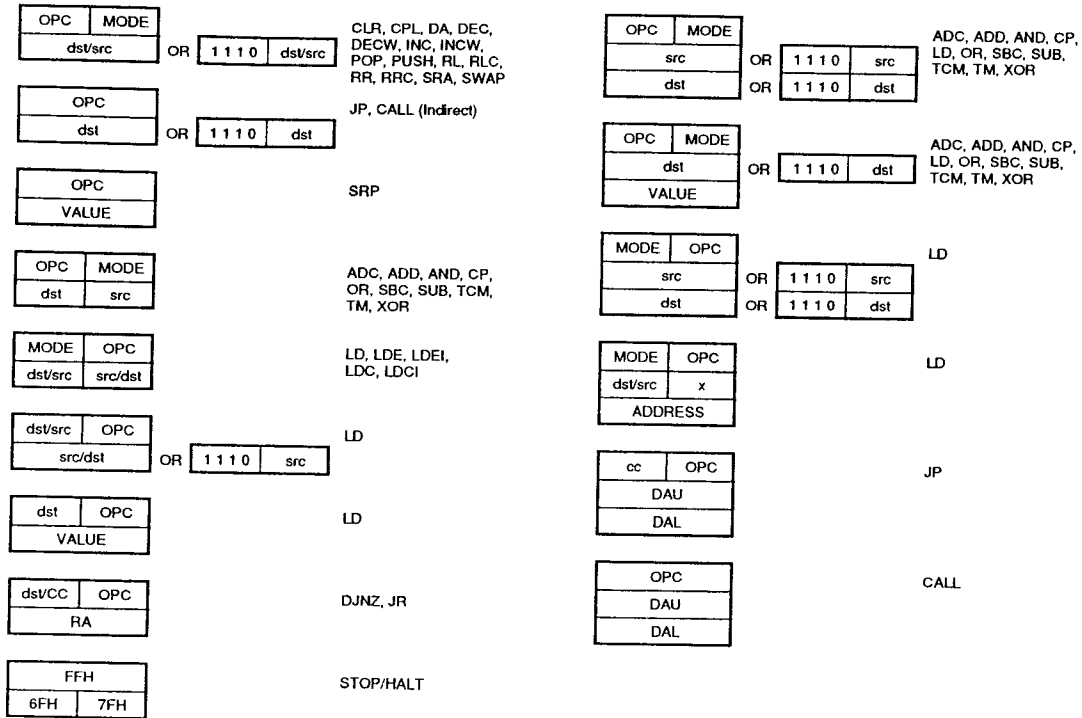

Two-Byte Instructions

Three-Byte Instructions

INSTRUCTION SUMMARY

Note: Assignment of a value is indicated by the symbol " \leftarrow ". For example:

$$dst \leftarrow dst + src$$

indicates that the source data is added to the destination data and the result is stored in the destination location. The

notation "addr (n)" is used to refer to bit (n) of a given operand location. For example:

$$dst(7)$$

refers to bit 7 of the destination operand.

INSTRUCTION SUMMARY (Continued)

Instruction and Operation	Address Mode	Opcode Byte (Hex)	Flags Affected							
			C	Z	S	V	D	H		
ADC dst, src dst←dst + src + C	†	1[]	*	*	*	*	0	*		
ADD dst, src dst←dst + src	†	0[]	*	*	*	*	0	*		
AND dst, src dst←dst AND src	†	5[]	-	*	*	0	-	-		
CALL dst SP←SP - 2 @SP←PC, PC←dst	DA IRR	D6 D4	-	-	-	-	-	-	-	-
CCF C←NOT C		EF	*	-	-	-	-	-	-	-
CLR dst dst←0	R IR	B0 B1	-	-	-	-	-	-	-	-
COM dst dst←NOT dst	R IR	60 61	-	*	*	0	-	-	-	-
CP dst, src dst - src	†	A[]	*	*	*	*	-	-	-	-
DA dst dst←DA dst	R IR	40 41	*	*	*	X	-	-	-	-
DEC dst dst←dst - 1	R IR	00 01	-	*	*	*	-	-	-	-
DECW dst dst←dst - 1	RR IR	80 81	-	*	*	*	-	-	-	-
DI IMR(7)←0		8F	-	-	-	-	-	-	-	-
DJNZr , dst r←r - 1 if r ≠ 0 PC←PC + dst Range: +127, -128	RA	rA r = 0 - F	-	-	-	-	-	-	-	-
EI IMR(7)←1		9F	-	-	-	-	-	-	-	-
HALT		7F	-	-	-	-	-	-	-	-

Instruction and Operation	Address Mode	Opcode Byte (Hex)	Flags Affected							
			C	Z	S	V	D	H		
INC dst dst←dst + 1	r R IR	rE r = 0 - F 20 21	-	*	*	*	*	-	-	-
INCW dst dst←dst + 1	RR IR	A0 A1	-	*	*	*	*	-	-	-
IRET FLAGS←@SP; SP←SP + 1 PC←@SP; SP←SP + 2; IMR(7)←1		BF	*	*	*	*	*	*	*	*
JP cc, dst if cc is true PC←dst	DA IRR	cD c = 0 - F 30	-	-	-	-	-	-	-	-
JR cc, dst if cc is true, PC←PC + dst Range: +127, -128	RA	cB c = 0 - F	-	-	-	-	-	-	-	-
LD dst, src dst←src	r r R r r X r lr lr R R R IR IR R	lm R r r X r lr r R R R IR IM IM R	rC r8 r9 r = 0 - F C7 D7 E3 F3 E4 E5 E6 E7 F5	-	-	-	-	-	-	-
LDC dst, src	r	lrr	C2	-	-	-	-	-	-	-
LDCI dst, src dst←src r←r + 1; rr←rr + 1	lr	lrr	C3	-	-	-	-	-	-	-

INSTRUCTION SUMMARY (Continued)

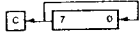
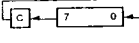
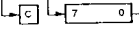
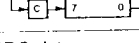
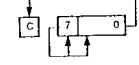
Instruction and Operation	Address Mode dst src	Opcode Byte (Hex)	Flags Affected						
			C	Z	S	V	D	H	
NOP		FF	-	-	-	-	-	-	-
OR dst, src dst ← dst OR src	†	4[]	-	*	*	0	-	-	-
POP dst dst ← @SP; SP ← SP + 1	R IR	50 51	-	-	-	-	-	-	-
PUSH src SP ← SP - 1; @SP ← src	R IR	70 71	-	-	-	-	-	-	-
RCF C ← 0		CF	0	-	-	-	-	-	-
RET PC ← @SP; SP ← SP + 2		AF	-	-	-	-	-	-	-
RL dst	R IR	90 91	*	*	*	*	*	-	-
									
RLC dst	R IR	10 11	*	*	*	*	*	-	-
									
RR dst	R IR	E0 E1	*	*	*	*	*	-	-
									
RRC dst	R IR	C0 C1	*	*	*	*	*	-	-
									
SBC dst, src dst ← dst ← src ← C	†	3[]	*	*	*	*	*	1	*
SCF C ← 1		DF	1	-	-	-	-	-	-
SRA dst	R IR	D0 D1	*	*	*	0	-	-	-
									
SRP src RP ← src	Im	31	-	-	-	-	-	-	-

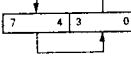
Instruction and Operation	Address Mode dst src	Opcode Byte (Hex)	Flags Affected						
			C	Z	S	V	D	H	
STOP		6F	-	-	-	-	-	-	-
SUB dst, src dst ← dst ← src	†	2[]	*	*	*	*	1	*	*
SWAP dst	R IR	F0 F1	X	*	*	X	-	-	-
									
TCM dst, src (NOT dst) AND src	†	6[]	-	*	*	0	-	-	-
TM dst, src dst AND src	†	7[]	-	*	*	0	-	-	-
XOR dst, src dst ← dst XOR src	†	B[]	-	*	*	0	-	-	-

† These instructions have an identical set of addressing modes, which are encoded for brevity. The first opcode nibble is found in the instruction set table above. The second nibble is expressed symbolically by a '[]' in this table, and its value is found in the following table to the left of the applicable addressing mode pair.

For example, the opcode of an ADC instruction using the addressing modes r (destination) and Ir (source) is 13.

Address Mode	Lower Opcode Nibble
dst src	
r r	[2]
r Ir	[3]
R R	[4]
R IR	[5]
R IM	[6]
IR IM	[7]

OPCODE MAP

		Lower Nibble (Hex)															
		0	1	2	3	4	5	6	7	8	9	A	B	C	D	E	F
Upper Nibble (Hex)	0	6.5 DEC R1	6.5 DEC IR1	6.5 ADD r1, r2	6.5 ADD r1, lr2	10.5 ADD R2, R1	10.5 ADD IR2, R1	10.5 ADD R1, IM	10.5 ADD IR1, IM	6.5 LD r1, R2	6.5 LD r2, R1	12/10.5 DJNZ r1, RA	12/10.0 JR cc, RA	6.5 LD r1, IM	12.10.0 JP cc, DA	6.5 INC r1	
	1	6.5 RLC R1	6.5 RLC IR1	6.5 ADC r1, r2	6.5 ADC r1, lr2	10.5 ADC R2, R1	10.5 ADC IR2, R1	10.5 ADC R1, IM	10.5 ADC IR1, IM								
	2	6.5 INC R1	6.5 INC IR1	6.5 SUB r1, r2	6.5 SUB r1, lr2	10.5 SUB R2, R1	10.5 SUB IR2, R1	10.5 SUB R1, IM	10.5 SUB IR1, IM								
	3	8.0 JP IRR1	6.1 SRP IM	6.5 SBC r1, r2	6.5 SBC r1, lr2	10.5 SBC R2, R1	10.5 SBC IR2, R1	10.5 SBC R1, IM	10.5 SBC IR1, IM								
	4	8.5 DA R1	8.5 DA IR1	6.5 OR r1, r2	6.5 OR r1, lr2	10.5 OR R2, R1	10.5 OR IR2, R1	10.5 OR R1, IM	10.5 OR IR1, IM								
	5	10.5 POP R1	10.5 POP IR1	6.5 AND r1, r2	6.5 AND r1, lr2	10.5 AND R2, R1	10.5 AND IR2, R1	10.5 AND R1, IM	10.5 AND IR1, IM								
	6	6.5 COM R1	6.5 COM IR1	6.5 TCM r1, r2	6.5 TCM r1, lr2	10.5 TCM R2, R1	10.5 TCM IR2, R1	10.5 TCM R1, IM	10.5 TCM IR1, IM								6.0 STOP
	7	10/12.1 PUSH R2	12/14.1 PUSH IR2	6.5 TM r1, r2	6.5 TM r1, lr2	10.5 TM R2, R1	10.5 TM IR2, R1	10.5 TM R1, IM	10.5 TM IR1, IM								7.0 HALT
	8	10.5 DECW RR1	10.5 DECW IR1	12.0 LDE r1, lr2	18.0 LDEI lr1, lr2												6.1 DI
	9	6.5 RL R1	6.5 RL IR1	12.0 LDE r2, lrr1	18.0 LDEI lr2, lrr1												6.1 EI
	A	10.5 INCW RR1	10.5 INCW IR1	6.5 CP r1, r2	6.5 CP r1, lr2	10.5 CP R2, R1	10.5 CP IR2, R1	10.5 CP R1, IM	10.5 CP IR1, IM								14.0 RET
	B	6.5 CLR R1	6.5 CLR IR1	6.5 XOR r1, r2	6.5 XOR r1, lr2	10.5 XOR R2, R1	10.5 XOR IR2, R1	10.5 XOR R1, IM	10.5 XOR IR1, IM								16.0 IRET
	C	6.5 RRC R1	6.5 RRC IR1	12.0 LDC r1, lrr2	18.0 LDCI lr1, lrr2				10.5 LD r1,x,R2								6.5 RCF
	D	6.5 SRA R1	6.5 SRA IR1	12.0 LDC r2, lrr1	18.0 LDCI lr2, lrr1	20.0 CALL* IRR1		20.0 CALL DA	10.5 LD r2,x,R1								6.5 SCF
	E	6.5 RR R1	6.5 RR IR1		6.5 LD r1, IR2	10.5 LD R2, R1	10.5 LD IR2, R1	10.5 LD R1, IM	10.5 LD IR1, IM								6.5 CCF
	F	8.5 SWAP R1	8.5 SWAP IR1		6.5 LD lr1, r2		10.5 LD R2, IR1										6.0 NOP

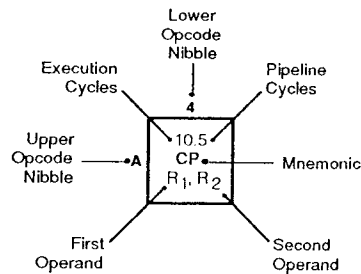

Legend:
R = 8-bit address
r = 4-bit address
R₁ or r₂ = Dst address
R₁ or r₂ = Src address

Sequence:
Opcode, First Operand,
Second Operand

Note: The blank are not defined.

* 2-byte instruction appears as a 3-byte instruction

ORDERING INFORMATION

Z86C91

12 MHz

40-pin DIP	44-pin PLCC	44-pin QFP
Z86C9112PSC	Z86C9112VSC	Z86C9112FSC
Z86C9112PEC	Z86C9112VEC	Z86C9112FEC

16 MHz

40-pin DIP	44-pin PLCC	44-pin QFP
Z86C9116PSC	Z86C9116VSC	Z86C9116FSC

20 MHz

40-pin DIP	44-pin PLCC	44-pin QFP
Z86C9120PSC	Z86C9120VSC	Z86C9120FSC

For fast results, contact your local Zilog sales office for assistance in ordering the part desired.

CODES

Package

P = Plastic DIP
V = Plastic Chip Carrier

Longer Lead Time

F = Plastic Quad Flat Pack

Temperature

S = 0°C to + 70°C
E = -40°C to + 105°C

Speed

12 = 12 MHz
16 = 16 MHz
20 = 20 MHz

Environmental

C = Plastic Standard

Example:

Z 86C91 12 P S C is an 86C91 12 MHz, DIP, 0°C to + 70°C, Plastic Standard Flow

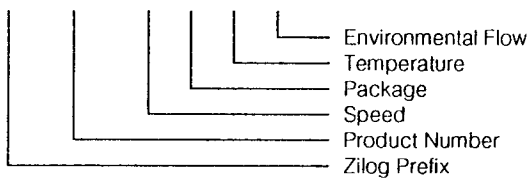

**ZILOG DOMESTIC SALES OFFICES
AND TECHNICAL CENTERS****CALIFORNIA**

Agoura 818-707-2160
Campbell 408-370-8120
Tustin 714-838-7800

COLORADO

Boulder 303-494-2905

FLORIDA

Largo 813-585-2533

GEORGIA

Norcross 404-448-9370

ILLINOIS

Schaumburg 708-517-8080

NEW HAMPSHIRE

Nashua 603-888-8590

NEW JERSEY

Clark 201-382-5700

NORTH CAROLINA

Raleigh 919-790-7706

OHIO

Independence 216-447-1480

PENNSYLVANIA

Ambler 215-653-0230

TEXAS

Dallas 214-987-9987

WASHINGTON

Seattle 206-523-3591

INTERNATIONAL SALES OFFICES**CANADA**

Toronto 416-673-0634

GERMANY

Munich 49-89-672-045
Sömmerda 37-626-23906

JAPAN

Tokyo 81-3-3587-0528

HONG KONG

Kowloon 852-7238979

KOREA

Seoul 82-2-552-5401

SINGAPORE

Singapore 65-2357155

TAIWAN

Taipei 886-2-741-3125

UNITED KINGDOM

Maidenhead 44-628-392-00

© 1991 by Zilog, Inc. All rights reserved. No part of this document may be copied or reproduced in any form or by any means without the prior written consent of Zilog, Inc. The information in this document is subject to change without notice. Devices sold by Zilog, Inc. are covered by warranty and patent indemnification provisions appearing in Zilog, Inc. Terms and Conditions of Sale only. Zilog, Inc. makes no warranty, express, statutory, implied or by description, regarding the information set forth herein or regarding the freedom of the described devices from intellectual property infringement. Zilog, Inc. makes no warranty of mer-

chantability or fitness for any purpose. Zilog, Inc. shall not be responsible for any errors that may appear in this document. Zilog, Inc. makes no commitment to update or keep current the information contained in this document.

Zilog, Inc. 210 East Hacienda Ave.
Campbell, CA 95008-6600
Telephone (408) 370-8000
Telex 171-980 A/B ZILOG CPTO
FAX 408 370-8056/8027