

# Agilent AEAS-7000 Plug and Play Ultra-Precision Absolute Encoder 16-bit Gray Code Data Sheet

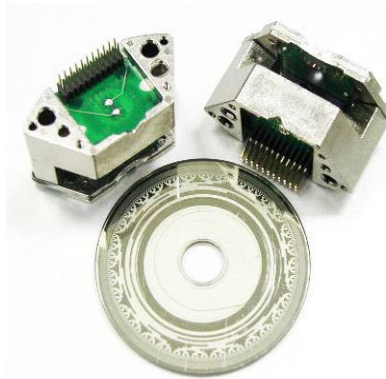

## Description

The encoder IC consists of 13 signal photo diode channels and 1 monitor photo diode channel and is used for the optical reading of rotary carriers (i.e., discs). The photodiodes are accompanied with precision amplifiers plus additional circuitry.

The monitor channel is used to drive a constant current source for the highly collimated IR illumination system.

## Functional Description

### Background

The 13 signal channels are set up as:

1. Two precision defining signals (A0, A09), which are two 90° electrical shifted sine, cosine signals. These signals are conditioned to be compensated for offset and gain errors. After conditioning they are on chip interpolated (4 bit) and computed to an absolute 6 bit Gray code. Additionally, these Sin/Cos signals can be tapped as two true-differential analog outputs to be used at the system designer's choice.

2. 11 analog (A1-A11) channels which are directly digitized by precision comparators with hysteresis tracking. The digitized signals are called D1-D11.

An internal correction and synchronization module allows the composition of a true 16 bit gray code by merging the data bits of 1) and 2) by still keeping the code monotony.

There is a Gray code correction feature for this encoder to counter any codewheel imperfection or misalignment. This Gray code correction can be disabled/enabled by the pin KORR.

The gain and offset conditioning value of the sine and cosine wave has been on-chip preset by factory. This will compensate for mechanical sensor misalignment error.

## Features

- Minimum mechanical alignment during installation
- 2 Sine/Cosine true differential outputs with 1024 periods for unit alignment
- Integrated highly collimated illumination system
- 11 digital tracks plus 2 sin/cos tracks generate precise 16 bit Gray code
- Ultra fast, 1  $\mu$ s cycle for serial data output word equals 16 MHz
- On-chip interpolation and code correction to compensate for mounting tolerance
- MSB can be inverted for changing the counting direction
- Internally built in monitor track for tracking the light level
- Watch dog with alarm output
- -25°C to +85°C operating temp.

## Applications

- Rotary application up to 16 bit/ 360° absolute position
- Rotary application up to 11 bit user defined code patterns
- Cost effective solution for direct integration into OEM systems



### Signal-Channels A1-A11

The photocurrent of the photo diodes is fed into a trans-impedance amplifier. The analog output of the amplifier has a voltage swing of (dark/light) about 1.3 V. Every output is transformed by precision comparators into digital signals (D1-D11). The threshold is at  $V_{DD}/2$  (=Analog-reference), regulated by the monitor channel.

### Monitor Channel with LED Control at Pins LEDR and LERR

The analog output signal of the monitor channel is regulated by the LED current. An internal bipolar transistor sets this level to  $V_{DD}/2$  (control voltage at pin LEDR). Thus the signal swing of each output is symmetrical to  $V_{DD}/2$  (=Analog-reference)

The error bit at pin LERR is triggered if the  $V_e$  of the internal bipolar transistor is larger than  $V_{DD}/2$ .

### Signals Channels A0, A09 with Signal Conditioning and Self Calibration

These two channels give out a sine and cosine wave which are 90 deg phase shifted. These signals have amplitudes which are almost constant due to the LED current monitoring. Due to amplifier mismatch the signals do have gain and offset errors. These errors are eliminated by an adaptive signal conditioning circuitry. The conditioning values are on-chip preprogrammed by factory. The analog output signals of A0 and A09 are supplied as true-differential voltage with a peak to peak value of 2.0 V at the pins A09P, A09N, A0P, A0N.

### Interpolator for Channels A0,A09

The interpolator generates the digital signals D0,D09 and D-1 to D-4. The interpolated signals D-1 to D-4 extend the 12 bit Gray code of the signals D11....D0 to form a 16 bit Gray code.

D0 and D09 are digitized from A0 and A09. The channels A0-A11 and A09 have very high dynamic bandwidth, which allows a real time monotone 12 bit Gray code at 12000 RPM.

The interpolated 16 bit Gray code can be used up to 1000 RPM only. At more than 1000 RPM, only the 12 bit Gray code from the MSB side can be used.

### LSB Gray Code Correction (Pin KORR)

This function block synchronizes the switching points for the 11 bit gray code of the digital signals D1 to D11 with D0 and D09 (digitized signal of A0 and A09).

This Gray code correction only works for the 12 bit MSB(4096 steps per revolution).

It does not work for the 4 excess interpolated bits of the 16 bit Gray code.

When some special applications require code patterns other than Gray code, the Gray code correction can be disabled by putting pin KORR = 0. When that happens just the 11 data bits (D1...D11) will be sent 1:1 to the DOUT serial output.

Gray code correction can be switched on or off by putting the pin KORR =1 (on) or =0 (off).

### MSBINV and DOUT Pins

The serial interface consists of a shift register. The most significant bit, MSB (D11) will always be sent first to DOUT. The MSB can be inverted (change code direction) by using pin MSBINV.

### DIN and NSL Pins

The Serial input DIN allows the configuration as ring register for multiple transmissions or for cascading 2 or more encoders. DIN is the input of the shift register that shifts the data to DOUT.

The NSL pin controls the shift register, to switch it between load (1) or shift (0) mode. Under load mode, DOUT will give the logic of the MSB, i.e., D11.

Under shift mode (0), coupled with the SCL, the register will be clocked, and gives out the serial word output bit by bit. As the clock frequency can be up to 16 MHz, the transmission of the full 16 bit word can be done within 1 $\mu$ s.

Valid data of DOUT should be read when the SCL clock is low. Please refer to timing diagram (Figure 2).

## Pinout Description

No.	Pin Name	Description	Function	Notes <sup>[1]</sup>
1	NC		Internally connected to cathode of LED	Do not use
2	KORR	Digital-input	1 = Gray Code Correction Active	CMOS, internal pu
3	PROBE_ON	Digital-Input	Do not use	CMOS, internal pd
4	PCL	Digital Input Positive Edge	Do not use	CMOS, internal pu
5	STCAL	Digital Input Positive edge Negative edge	To be ground	CMOS, internal pd
6	MSBINV	Digital-Input	1 = MSB inverted	CMOS, internal pd
7	DIN	Digital Input	Shift Register input. Used for cascading only	CMOS, internal pd
8	NSL	Digital-Input	Shift-register Shift (=0) / Load (=1) Control	CMOS, internal pu
9	SCL	Digital-Input Positive Edge	Shift-register Shift Clock	CMOS, internal pu
10	DOUT	Digital Output	Shift-Register Data Out (MSB first)	CMOS, 2 mA
11	DO	Digital Output	DO signal	CMOS, 2 mA
12	DPROBE	Digital Output	D09 signal	CMOS, 2 mA
13	VDD	Supply Voltage	+5 V Supply Digital	
14	GND	Gnd for supply voltage	GND for 5 V supply analog/digital	
15	A09P	Analog output	A09 positive (+True diff.)	CMOS, analog out
16	GND	Gnd for supply voltage	GND for 5 V supply analog/digital	
17	A0P	Analog Output	A0 positive (+True diff.)	CMOS, analog out
18	A09N	Analog output	A09 negative (-True diff.)	CMOS, analog out
19	VDDA	Supply Voltage	+5 V Supply Analog	
20	A0N	Analog Output	A0 negative (-True diff.)	CMOS, analog out
21	LERR	Digital Output	IR-LED Current Limit Signal	CMOS, 2 mA
22	LEDR	Analog Output	Do not use	CMOS, analog out

Note:

1. Internal pu/pd = internal pull-up (typ. 50  $\mu$ A)/ pull-down (typ. 10  $\mu$ A) CMOS-transistor-Rs.

## Pinout Configuration

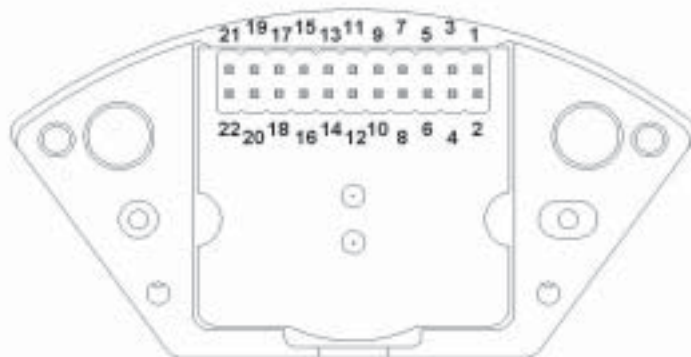

ESD WARNING: HANDLING PRECAUTIONS SHOULD BE TAKEN TO AVOID STATIC DISCHARGE

## Using the AEAS-7000

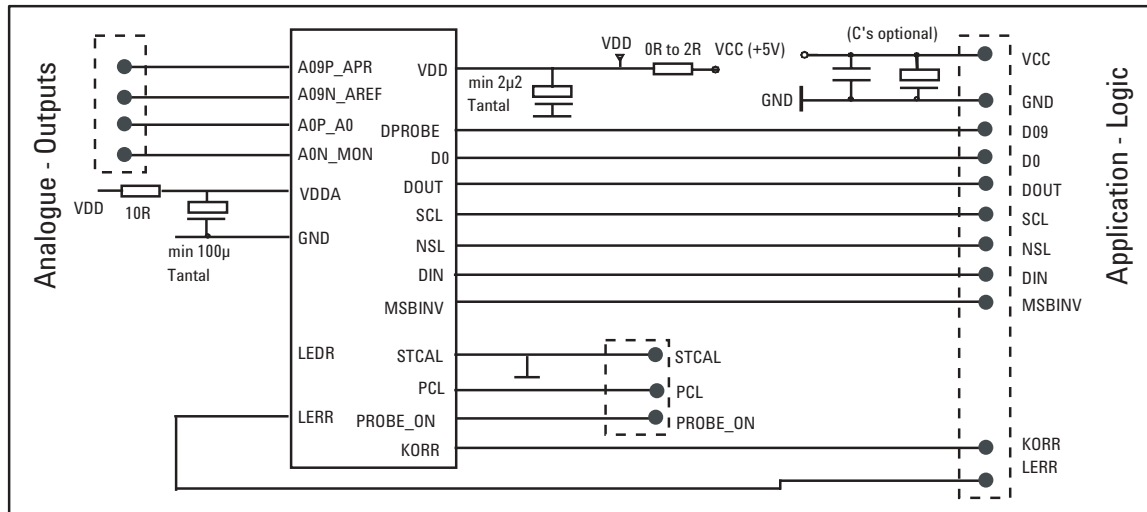

Figure 1. Schematic using AEAS-7000.

Note: The RC-filter combination, especially on VDDA, is used to filter spikes and transients and is strongly recommended. It is advised that the tantalum caps be put as close to the VDD and VDDA pins as possible.

It is recommended to ground the PROBE\_ON pin during normal operation.

Leave PCL unconnected.

A09N and A0N are the negative cosine and sine waves, the negative versions of A09P and A0P.

D0 is used to check the D0 signal. D0 is the digitized signal of A0. DPROBE is used to check D09, the digitized signal of A09. Recommended to be used for testing purpose only.

KORR is for Gray Code correction for 12 bits resolution only.

MSBINV is for user to change between counting up and counting down for a given rotating direction. MSB(D11) will always be sent out to DOUT first.

LEDR, do not connect to this pin.

LERR will be high when the light output of the emitter is low. This is an indicator when light intensity is at a critical stage affecting the performance of the encoder. It is caused by contamination of the codewheel or LED degradation.

### Operation

- 1) After powering up the unit using  $V_{CC} = +5\text{ V}$  and connecting GND to ground, trigger input pins NSL and SCL using the timing diagram below (Figure 2). NSL is a control pin for the internal shift register. When triggered to low and combined with clock pulses, the serial Gray code will be shifted out to DOUT bit by bit per every clock pulse
- 2) The 16 bit serial gray code can then be tapped out from the pin DOUT, most significant bit (D11) first.

The rate of the 16 bit Gray code serial transfer rate is dependent on the SCL clock frequency. The faster the clock, the faster the transfer rate. The maximum clock rate the AEAS-7000 can take is 16 MHz, which means the entire 16 bit Gray code can be serially transferred out in 1  $\mu\text{s}$ .

- 3) Whenever NSL is high, the DOUT will have the logic of the MSB D11. After NSL goes low, the number of bits being transferred out will depend on the number of clock pulses given to SCL. The default is 16 clock pulses for the 16 bit Gray code. If for other application where another number other than 16 is needed, just supply the corresponding number of clock pulses to the SCL, e.g., 12 bit, 13 bit, 14 bit or 15 bit, and you will get the corresponding length of Gray code words with the corresponding resolution.

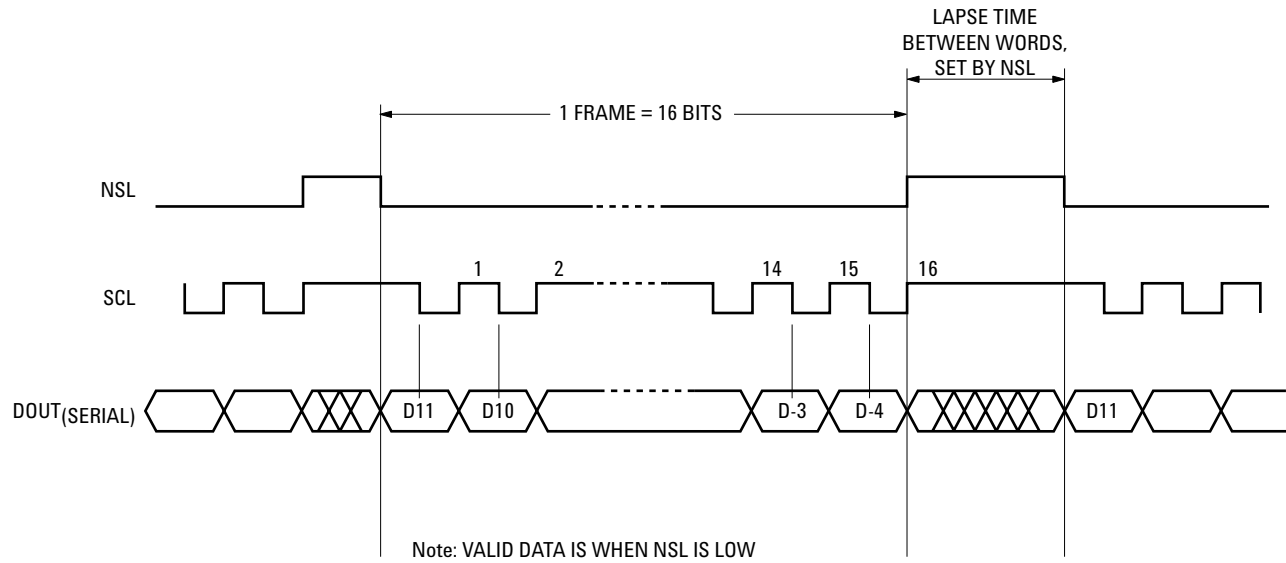

Figure 2. Timing diagram.

### Absolute Limits

No.	Parameters	Symbol	Min.	Typ.	Max.	Units
1	Supply Voltage	VD	-0.3		6.0	V
2	Voltages at all Input and Output Pins	Vin , Vout	-0.3		VD + 0.3	V
3	Operating Temperature	TA	-25		+85	°C
4	Storage Temperature	TS	-40		+100	°C

### Operating Conditions

No.	Parameters	Symbol	Min.	Typ.	Max	Units
1	Supply Voltage	VD	4.5	5	5.5	V
2	Operating Temperature	TA	-25	25	+85	°C
3	Input-H-Level	Vih	0.7*VD		VD	V
4	Input-L-Level	Vil	0		0.3*VD	V

**Electrical Characteristics (VD = 4.5 to 5 V, TA = -40 to +85 °C)**

No.	Parameters	Symbol	Conditions	Min.	Typ.	Max.	Units
<b>Operating Currents</b>							
1	Total Current	I total			25		mA
<b>Digital Inputs</b>							
1	Pull Down Current	Ipd		-20		-5	μA
2	Pull Up Current	Ipu		30		160	μA
<b>Digital Outputs</b>							
1	Output-H-Level	Voh	Ioh = 2 mA	VD - 0.5 V		VD	V
2	Output-L-Level	Vol	Iol = -2 mA	0		0.5	V
<b>Serial Interface</b>							
1	SCL Clock Frequency	fclock				16	MHz
2	Duty Cycle Fclock	T clock,LH	Fclock = 16 MHz	0.4		0.6	ns
3	Accuracy (1)		Fclock = 5MHz, RPM = 80		±2bits		
<b>Analog-Signal-Conditioning – Signaltracks A0P,A0N,A09P,A09N</b>							
1.	Signal Frequency A0, A09	Fsine,cos		0		250	KHz

**Note 1:**

Accuracy would be influenced by installation control and the bearing and shaft type being used.

**Test conditions to determine Accuracy**

- 1) 80 RPM
- 2) 25 °C, room temperature
- 3) At nominal radial, tangential and gap position
- 4) On dual preloaded bearing with absolute assembly concentricity of not exceeding 10 microns
- 5) SCL frequency of 5MHz
- 6) Both VDD & VDDA filter capacitor placed not more than 20mm from header pins
- 7) Tested for one revolution

## Mounting Consideration

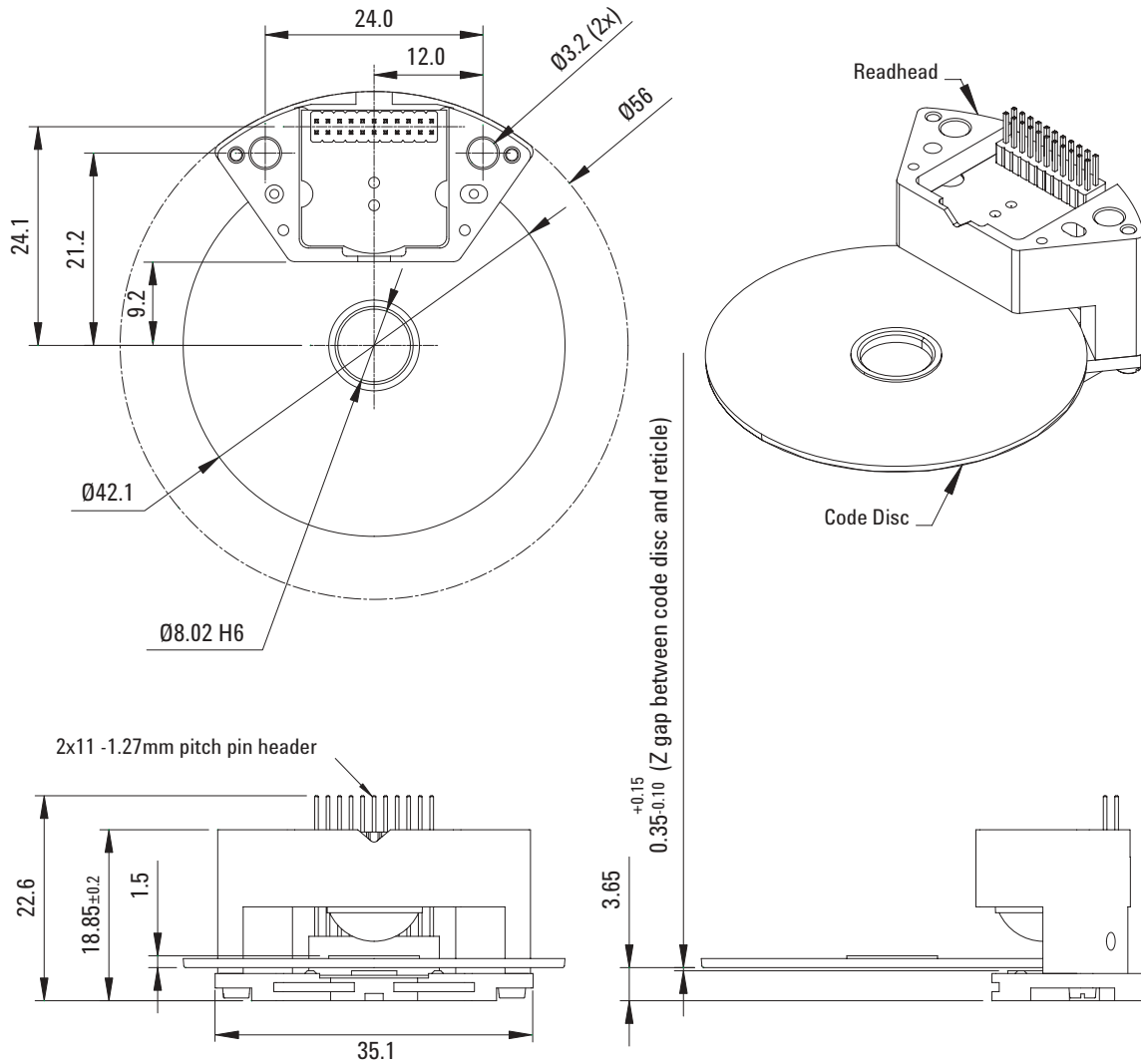

UNLESS SPECIFIED OTHERWISE  
DIMENSIONS ARE IN MILLIMETRES  
THIRD ANGLE PROJECTION

XX.	0.3	STRIKE OUT
XX.X	0.1	OR FILL IN
XX.XX	0.03	AS NEEDED

**Note:** Codewheel mounting tolerances for radial, tangential and Z gap are:

Radial:	$\pm 50 \text{ um}$
Tangential:	$\pm 40 \text{ um}$
Z Gap:	$\pm 50 \text{ um}$





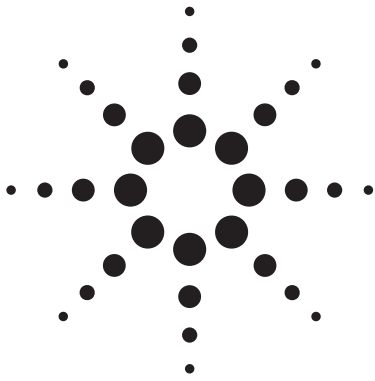

# AEAS-7000 Plug and Play Installation Considerations

## Application Note 5048

### Introduction

AEAS-7000 comes in the form of an absolute encoder read-head and absolute code disk. The AEAS-7000 plug and play concept basically eliminates the need for tedious manual alignment of photodiodes and code disk. Design of the AEAS-7000 gives the user the ease of use during installation with minimum alignment required.

### Mounting Considerations for AEAS-7000

Figure 1 shows the package outline of the AEAS-7000. The device comes with a standard 1.27 mm pitch header pin.

Figures 2 and 3 are guidelines for mounting the AEAS-7000 to a motor bearing stage.

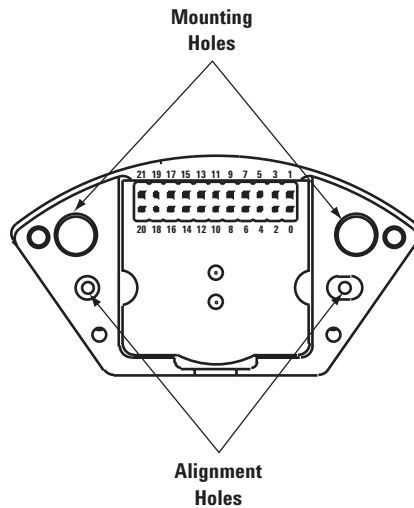
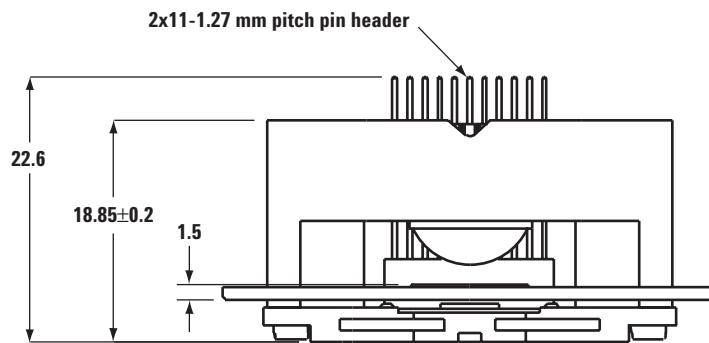
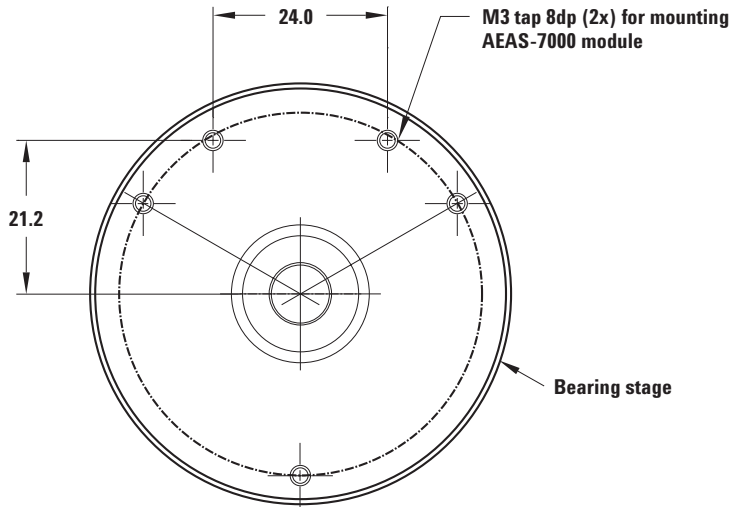

Figure 1. Package outline of the AEAS-7000.



Dimensions are in millimeters.

Figure 2. Mounting hole dimensions for AEAS-7000.

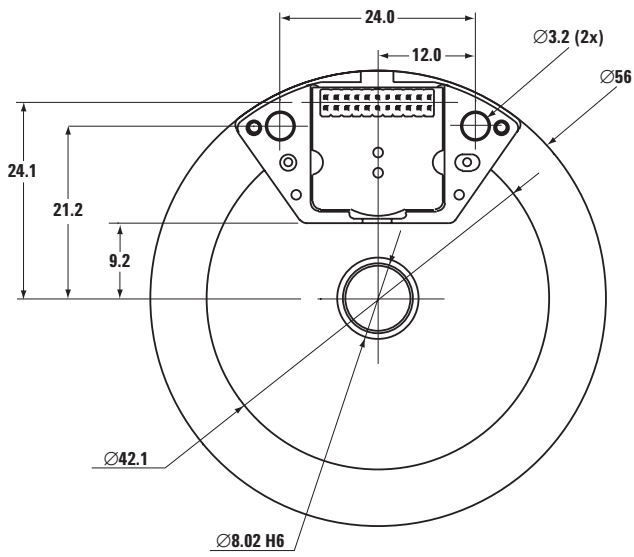

Figure 3. Mounting of AEAS-7000 on a bearing stage as shown in Figure 2.

In Figure 4, an example is given of an application whereby the AEAS-7000 is mounted onto a bearing stage with the code disk attached to a hub-shaft. The code disk hub-shaft is *not* provided by Agilent Technologies.

Figure 5 details the design of the hub-shaft of which the dimensions must be strictly followed for the plug and play feature of the AEAS-7000 to work.

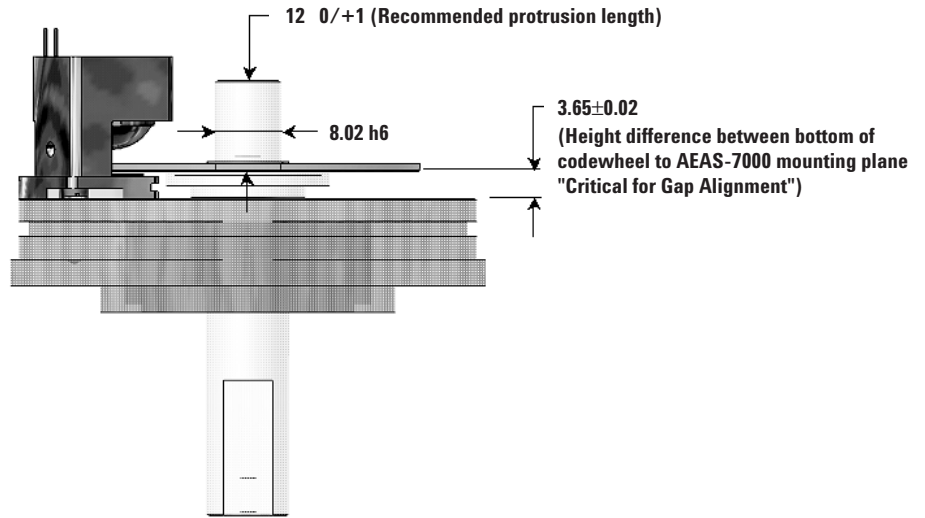

Figure 4. Mounting of AEAS-7000 on a housed-encoder flange.

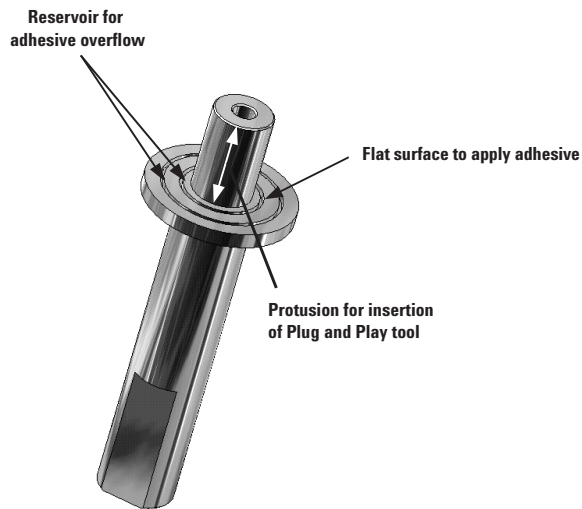

Figure 5. Illustration of the hub-shaft design.

The hub-shaft is *not* provided by Agilent Technologies, and must be fabricated by the customer as per design details in Figure 6. In order to secure the code disk to the hub, an adhesive must be utilised. Agilent recommends using DELO-DUOPOX, 1895 from DELO. Stainless steel is recommended as the hub-shaft material.

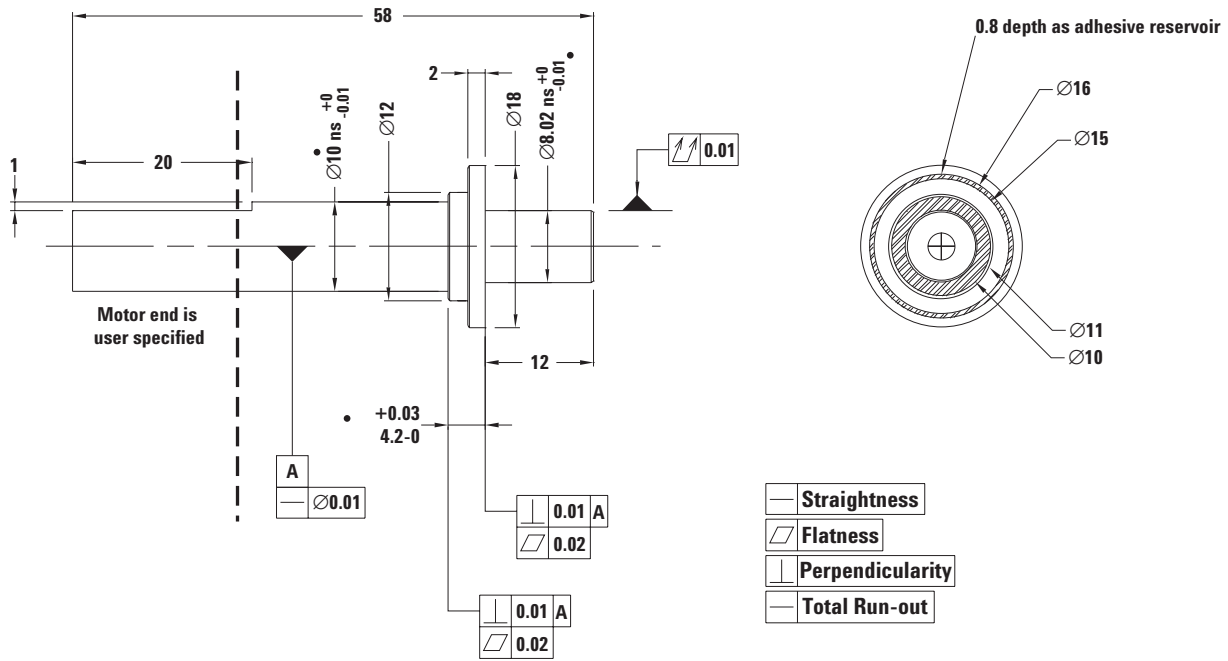

Figure 6. Design detail of hub-shaft for plug and play features.

## Codewheel to Hub Assembly

### Step 1

The code disk is secured on the code disk hub-shaft with adhesive. Adhesive must be applied on the flat surface of the hub as detailed in Figure 5.

### Step 2

Referring to Figure 7, ensure the code disk orientation is correctly positioned. The artwork of the code disk needs to be facing down toward the detector. The artwork is the opposite to the protrusion on the inner diameter of the code disk.

### Step 3

Pressing near the ID of the codewheel is required to ensure the codewheel sits flush to the hub.

### Step 4

Adhesive Curing

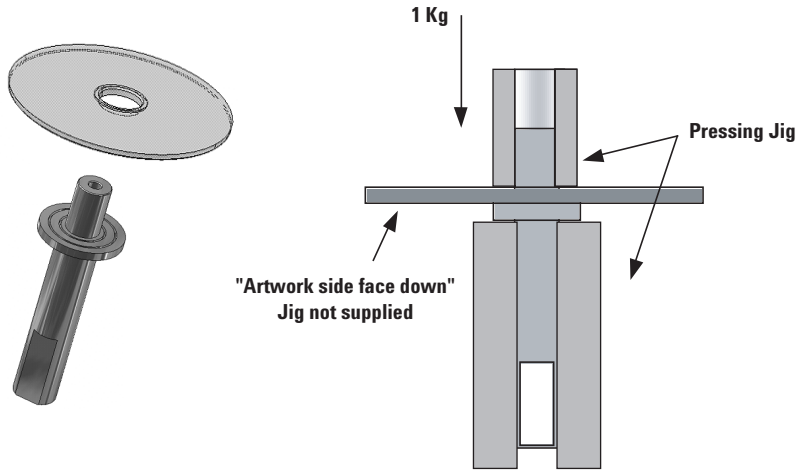

Figure 7. Attaching the codewheel to hub-shaft assembly using a pressing jig.

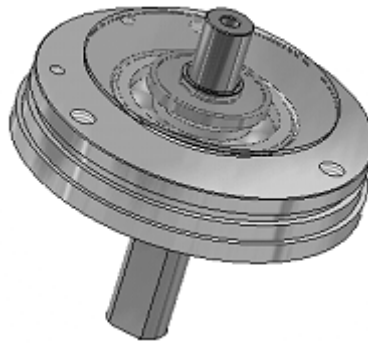

Figure 8. Shows a shafted code disk assembled onto a bearing stage.

## AEAS-7000 Installation

### Step 1

AEAS-7000 must be carefully positioned on the bearing stage. Care must be taken to avoid knocking the code disk during this process, which has a risk of damaging the code disk. Check to ensure that the code disk still can make a smooth rotation.

### Step 2

The encoder is secured with 25 mm length M3 size screws. The mounting holes are used for this purpose. At this point the screws are not tightened, as the alignment process is next.

### Step 3

Next is the alignment process. Locate the plug and play tool eagle claw in the readhead alignment holes and the hub protrusion. In this position the AEAS-7000 is correctly aligned to the code disk.

### Step 4

With the plug and play tool in place, the AEAS-7000 is correctly aligned to the code disk. Tighten the mounting screws to fix the location of the AEAS-7000 unit in the aligned position. While tightening the screws, lightly press a finger at the center of the plug and play tool. This will ensure the tool sits flush on the codewheel. Recommended torque force to secure the screw is 7 lb in or 0.79 Nm, which will able the unit to withstand vibrations of up to 5G.

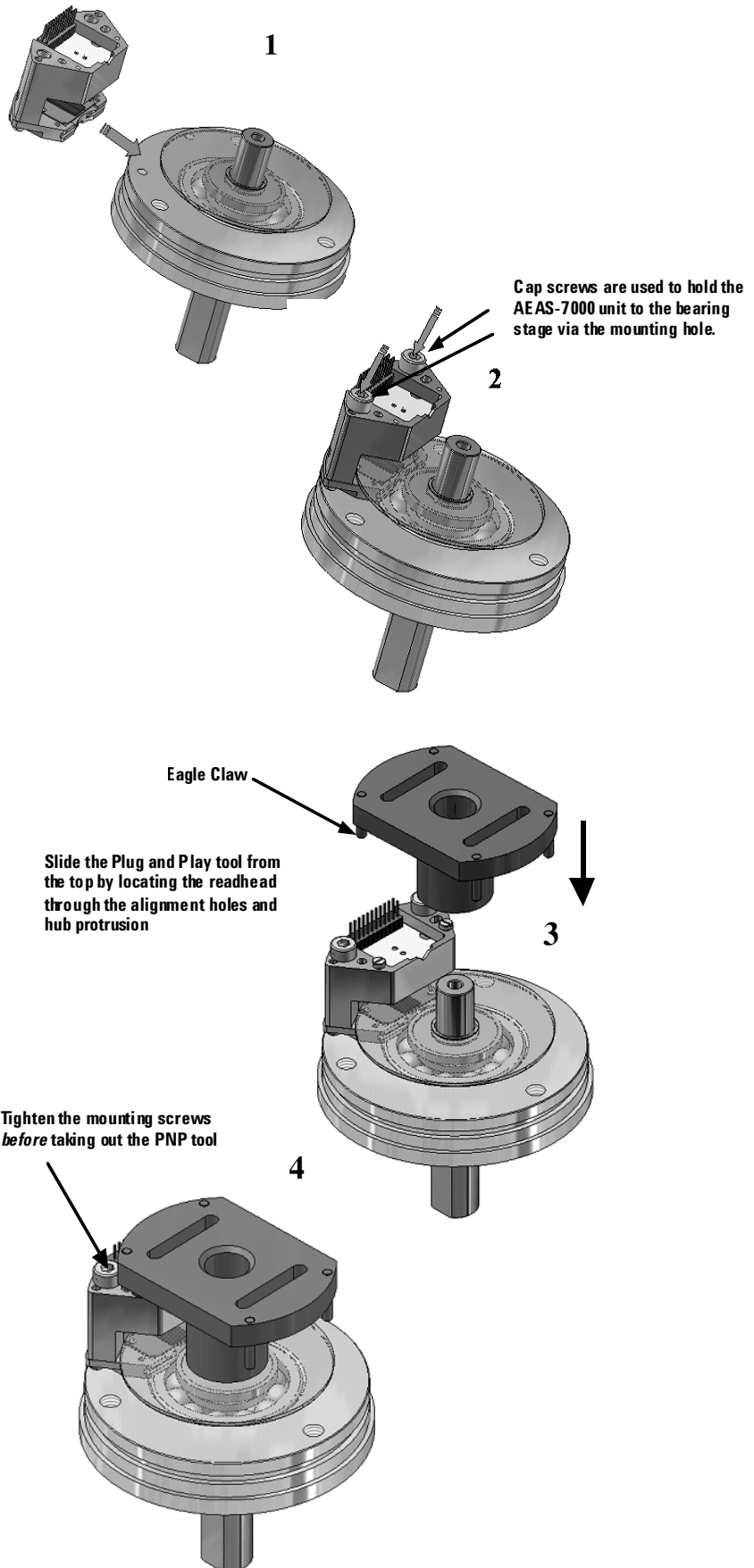

**[www.agilent.com/semiconductors](http://www.agilent.com/semiconductors)**

For product information and a complete list of distributors, please go to our web site.

For technical assistance call:

Americas/Canada: +1 (800) 235-0312 or  
(916) 788-6763

Europe: +49 (0) 6441 92460

China: 10800 650 0017

Hong Kong: (65) 6756 2394

India, Australia, New Zealand: (65) 6755 1939

Japan: (+81 3) 3335-8152(Domestic/International), or  
0120-61-1280(Domestic Only)

Korea: (65) 6755 1989

Singapore, Malaysia, Vietnam, Thailand, Philippines,  
Indonesia: (65) 6755 2044

Taiwan: (65) 6755 1843

Data subject to change.

Copyright © 2004 Agilent Technologies, Inc.

February 20, 2004

5989-0731EN



**Agilent Technologies**