



MINITEK™ CONTACT

STRIPPER-CRIMPER MK 271

- Simple and reliable
- High speed crimping
- Strips and crimps the wire in one operation
- Lightweight construction
- Pneumatically operated
- Adjustable tooling
- High quality results

ORDERING DATA

MK 271 Press & Tooling	AWG 26-30	193315-01
Tooling Kit	AWG 26-30	193317-01
DX 271 Press only		193316-01

Application rate/hour	1500 (depending on operator dexterity)
Weight	32 kg
Dimensions (h x w x d)	980 x 600 x 400 mm
Working height above table	85 mm
Air consumption / min.	61 NI
Air pressure	5-6 Bar

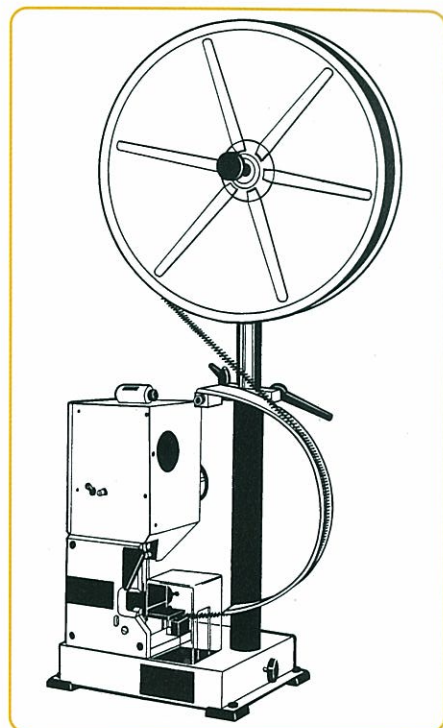

HAND TOOL HT 151 / HT 152

- Lightweight hand tool
- Rugged
- Ratched-action handle assures complete crimp cycle

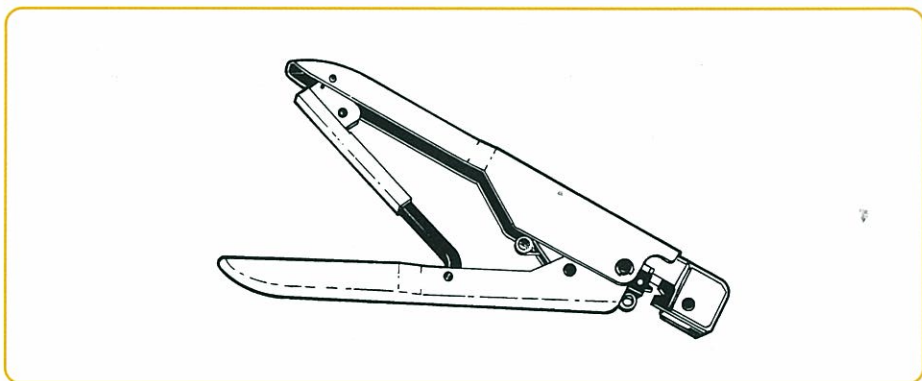

ORDERING DATA

For use with Dubox™ contacts, on reel

	AWG 26-30	HT 151
	AWG 32-36	HT 152



DUBOX™ CONTACT

STRIPPER-CRIMPER DX 271

- Simple operation
- Reliable
- Pneumatically operated
- Low maintenance cost
- High quality results

ORDERING DATA

MK 411 Press & Tooling	AWG 26-30	194294-01
MK 411 Press & Tooling	AWG 32-36	194294-02

Application rate/hour	1800 (depending on operator dexterity)
Weight	25 kg
Dimensions (h x w x d)	710 x 560 x 400 mm
Working height above table	110 mm
Air consumption / min.	28 NI
Air pressure	5-6 Bar
Electrical requirements	220-240V, 50Hz, 0,5A

