

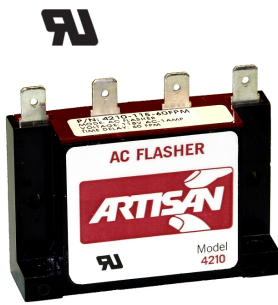

Solid State Timers and Controllers



4210

Solid State AC Flasher

The Model 4210 is an all solid state flasher intended for use in AC circuits only. Capable of flashing a load circuit up to one ampere at a fifty percent duty cycle. Output switch is ON for as long as it is OFF. Flash rates from 1 flash per minute up to 300 flashes per minute are available in five operating voltage ranges. The model 4210 has internal transient protection devices to assure reliable operation even when driving inductive load circuits such as relays or solenoids.

Mechanical & Wiring

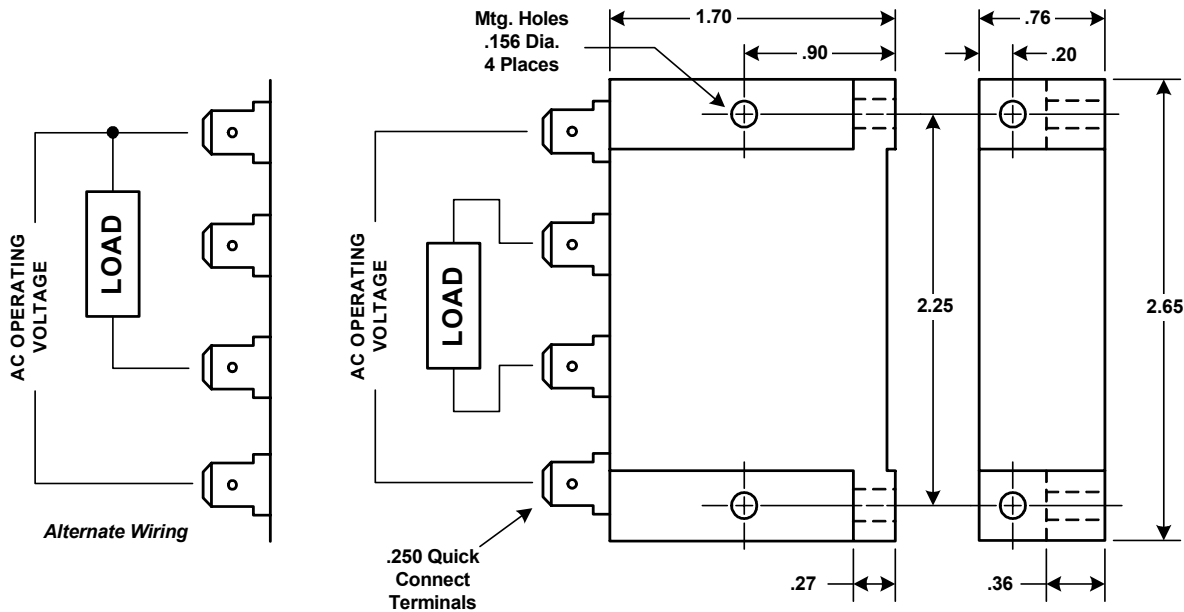

Timing Diagram

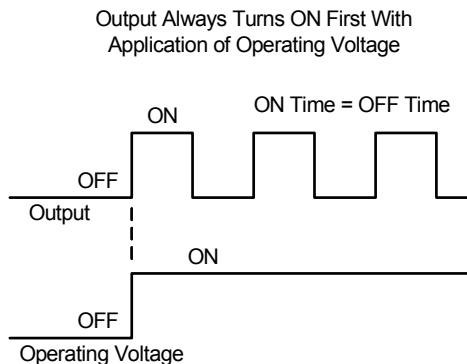

How To Find The Flash Rate

The timing diagram shown below is for an application that requires the load circuit to be ON for 750 milliseconds and OFF for 750 milliseconds. (Remember - the ON and OFF times will essentially be equal due to the 50% duty cycle specification inherent in the model 4210)

The voltage across the load circuit would look something this:

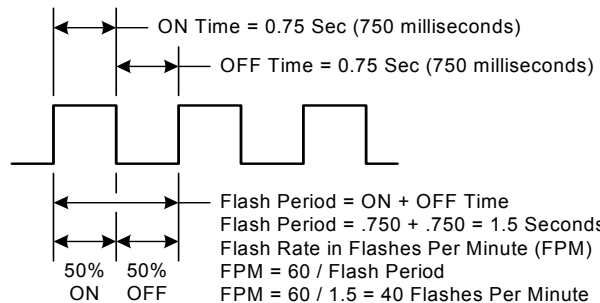

VISIT OUR WEB SITE AT : www.artisancontrols.com

Notice: Artisan Controls Corporation assumes no responsibility for customers applications or product design. The information and data contained herein is the sole and exclusive property of Artisan Controls Corporation. Any duplication, misuse, or conversion of this information without the express written consent of Artisan Controls Corporation is illegal and will result in damages including court costs and attorney fees being assessed against the party misusing this property

Tel: 973-598-9400 • Fax: 973-598-9410 • Toll Free: 800-457-4950
 Artisan Controls Corporation, 111 Canfield Ave., Bldg B15-18, Randolph, NJ, 07869, USA



Solid State Timers and Controllers

Specifications

- Operating Voltage:** AC only (12, 24, 48, 115, 230) 50/60 Hz.
- Voltage Tolerances:** ±15%.
- Timing Mode:** Flasher.
- Fixed Flash Rate:** Factory fixed at any rate from 1 to 300 flashes-per-minute (FPM)
- Fixed Flash Duty Cycle:** 50%.
- Flash Rate Duty Cycle Tolerance:** ±10% (2% nominal).
- Tolerances On Fixed Timing:** 2%, 5%, 10%, and 20% available.
- Flash Rate Variation:** Less than 4% of set point over full temperature and voltage range.
- Repeatability Of Flashing Period:** ±2% at stabilized operating voltage temperature.
- Recycle Time:** Operating voltage must be removed for a minimum of 200 milliseconds to assure that timing and output circuits are reset. If it is not a requirement that the load circuit always be energized when operating voltage is reapplied, the operating voltage may be re-applied at any time.
- Output Rating:** 10mA to 1A inductive with inrush current to 8A for 8 milliseconds.
- Output Switch Voltage Drop:** 3 volts AC maximum when load circuit is energized.
- Output Switch Leakage Current:** 3 mA maximum when load circuit is de-energized.
- Transient Protection:** Output switch protected by silicon transient suppressors responding to transients within 1×10^{-12} seconds to a peak pulse power dissipation of 1500 watts, with transient surge currents to 200 amperes for durations up to 1/120 second at 25° C. Maximum transient voltage protection is 6000 volts as delivered through a source resistance of 30 ohms with a maximum duration of 8.3ms.
- Dielectric:** 1500V rms all terminals to case.
- Operating Temperature:** -20°C to +85°C
- MTBF Rating:** 50,000 hrs minimum.
- Construction:** Encapsulated module with .25 quick connect wiring terminals.
- Agency Recognitions:** UL File E47858, Appliance Controls - Component ATNZ2, Auxilliary Devices - Component NKCR2.
- Data Sheet Revision Date:** February 21, 2006

Ordering Information

Part Number - Operating Voltage - Flash Rate (FPM)		
4210 -	12	Specify Fixed
	24	Flash Rate
	48	Required From
	115	1 to 300 Flashes
	230	Per Minute (FPM)

Part Number Examples

4210-24-90FPM A model 4210 operating from 24V AC with a flash rate of 90 flashes-per-minute (FPM)
The load circuit will be ON for 333mS and OFF for 33mS.

4210-115-60FPM A model 4210 operating from 115V AC with a flash rate of 60 flashes-per-minute (FPM)
The load circuit will be ON for 500mS and OFF for 500 mS.

VISIT OUR WEB SITE AT: www.artisancontrols.com

Notice: Artisan Controls Corporation assumes no responsibility for customers applications or product design. The information and data contained herein is the sole and exclusive property of Artisan Controls Corporation. Any duplication, misuse, or conversion of this information without the express written consent of Artisan Controls Corporation is illegal and will result in damages including court costs and attorney fees being assessed against the party misusing this property

Tel: 973-598-9400 • Fax: 973-598-9410 • Toll Free: 800-457-4950
Artisan Controls Corporation, 111 Canfield Ave., Bldg B15-18, Randolph, NJ, 07869, USA