

## Surface Mount Detection Switch

## D3SH

The smallest detection switch in the world. (OMRON's data as of June 2006.)

- Ultra small size and ultra low profile contributing to down-sizing of sets devices.  
(3.0 × 3.4 × 0.9 mm (W × D × H))
- A unique mechanism enables high contact reliability and high precision operation.
- Horizontal 2-way detection and long stroke for easy installation are available.
- Meet a variety of applications by contact and lever variations.

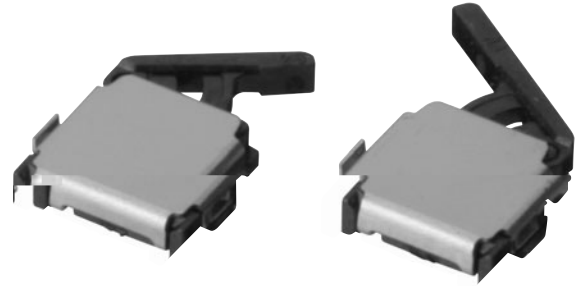

**NEW**

## Ordering Information

### Model Number Legend

**D3SH-**

①    ②    ③

① **Contact Form**

A: SPST-NO  
B: SPST-NC

② **Boss of Positioning**

0: with Boss  
1: without Boss

③ **Lever and Detection of Operation**

R : Right operating with standard lever  
L : Left operating with standard lever  
R1: Right operating with long lever  
L1: Left operating with long lever

### List of Models

#### Standard Lever Models

Contact form	Direction of Operation	Boss of Positioning	Model	Packing form
SPST-NO	Right	With Boss	D3SH-A1R	Embossed tape packing (see note)
		Without Boss	D3SH-A0R	
	Left	With Boss	D3SH-A1L	
		Without Boss	D3SH-A0L	
SPST-NC	Right	With Boss	D3SH-B1R	Embossed tape packing (see note)
		Without Boss	D3SH-B0R	
	Left	With Boss	D3SH-B1L	
		Without Boss	D3SH-B0L	

**Note:** Minimum packing unit is 1,000 pcs./reel.

#### Long Lever Models

Contact form	Direction of Operation	Boss of Positioning	Model	Packing form
SPST-NO	Right	With Boss	D3SH-A1R1	Embossed tape packing (see note)
		Without Boss	D3SH-A0R1	
	Left	With Boss	D3SH-A1L1	
		Without Boss	D3SH-A0L1	
SPST-NC	Right	With Boss	D3SH-B1R1	Embossed tape packing (see note)
		Without Boss	D3SH-B0R1	
	Left	With Boss	D3SH-B1L1	
		Without Boss	D3SH-B0L1	

**Note:** Minimum packing unit is 1,000 pcs./reel.

# Specifications

## ■ Ratings

Rated voltage	Resistive load
5 VDC	1 mA

**Note:** The ratings values apply under the following test conditions:  
 Ambient temperature :  $20 \pm 2$  °C  
 Ambient humidity:  $65 \pm 5$  %  
 Operating frequency: 30 operations/min.

## ■ Characteristics

Operating speed	1 mm to 300 mm/s
Operating frequency	Mechanical: 20 operations/min max. Electrical: 20 operations/min max.
Insulation resistance	100 M $\Omega$ min. (at 100 VDC)
Contact resistance (initial value)	3 $\Omega$ max.
Dielectric strength	100 VAC for 1 min between terminals of same polarity
Vibration resistance (see note 2)	Malfunction: 10 to 55 Hz, 1.5-mm double amplitude
Shock resistance (see note 2)	Destruction: 1000 m/s <sup>2</sup> {approx. 100 G} max. Malfunction: 300 m/s <sup>2</sup> {approx. 30 G} max.
Durability(see note 3)	Mechanical: 150,000 operations min. (20 operations/min.) Electrical: 100,000 operations min. (20 operations/min.)
Ambient operating temperature	-25 °C to 85 °C (at ambient humidity of 60 % max.) (with no icing or condensation)
Ambient operating humidity	85 % max.(for 5 °C to 35 °C )
Weight	Approx. 0.02 g

**Note:** 1. The data given above are initial values.  
 2. The values apply at the total travel position. Contact opening or closing time is within 1ms.  
 3. For testing conditions, consult your OMRON sales representative.

## ■ Contact Specifications

Contact Specification	Slide
Minimum applicable load	15 $\mu$ A at 3 VDC

## ■ Contact form

### SPST-NO

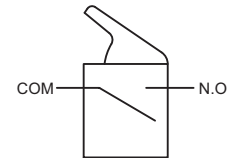
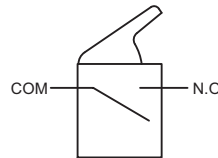

### SPST-NC

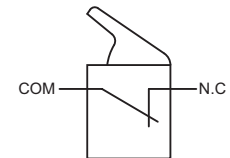
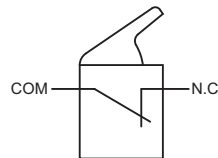

**Note:** The cover connects with COM terminal inside.

# Dimensions

## ■ Packaging Specifications

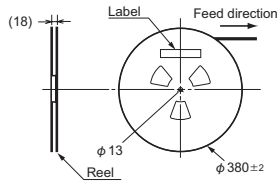
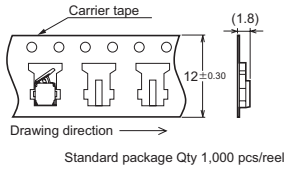

<b>Standards</b>	Conforms to JEITA
<b>Package</b>	Qty 1,000 pcs/reel

## ■ Dimensions and Operating Characteristics

**Note:** 1. All units are in millimeters unless otherwise indicated.

2. Unless otherwise specified, a tolerance of ± 0.15 mm applies to all dimensions.

3. The operating characteristics are for operation in the A direction ( ↓ ) and B direction ( → , ← ).

### Standard Lever Models

Model	D3SH-□□ R D3SH-□□ L
Operating force (OF) max.	0.3 N {31 gf}
Free position (FP)	5.4 ± 0.2 mm
Operating position (OP)	5.0 ± 0.2 mm
Total travel position (TTP)	3.8 ± 0.15 mm

### Right operating - without Boss

D3SH-□ 0R

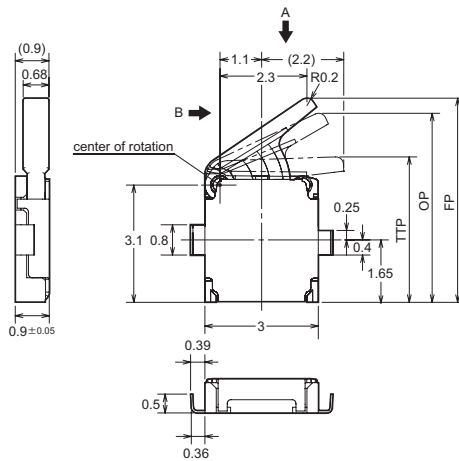

PCB mounting land Dimension (Reference)  
(View from switch top)

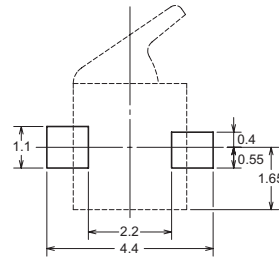

### Left operating - without Boss

D3SH-□ 0L

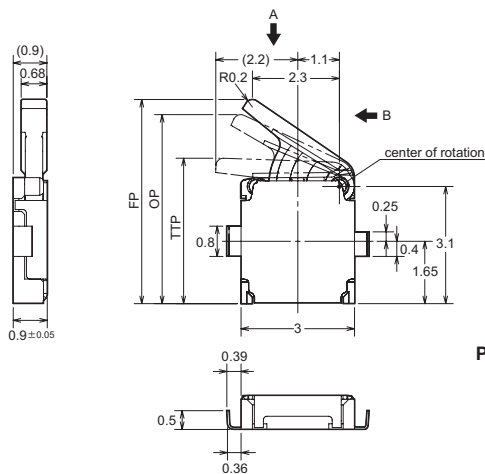

PCB mounting land Dimension (Reference)  
(View from switch top)

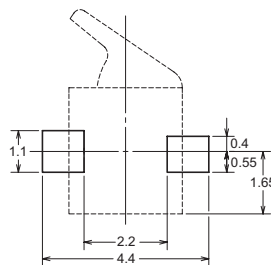

Right operating - with Boss

D3SH-□ 1R

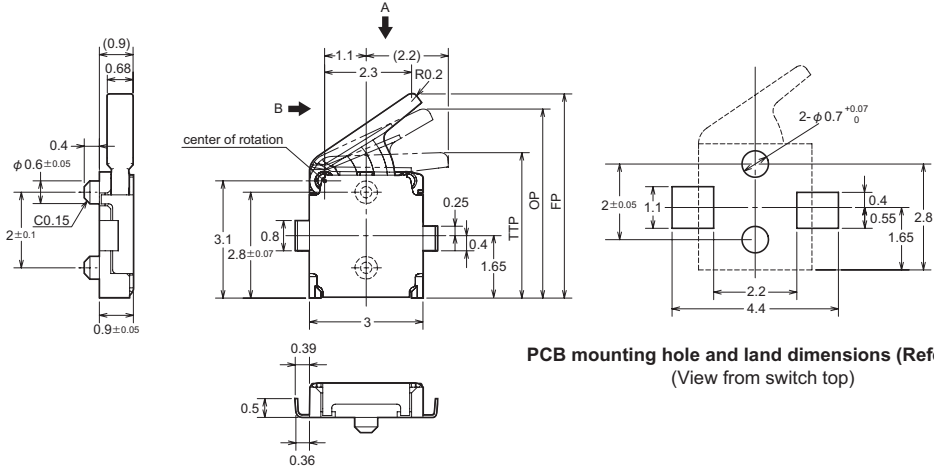

PCB mounting hole and land dimensions (Reference)  
(View from switch top)

Left operating - with Boss

D3SH-□ 1L

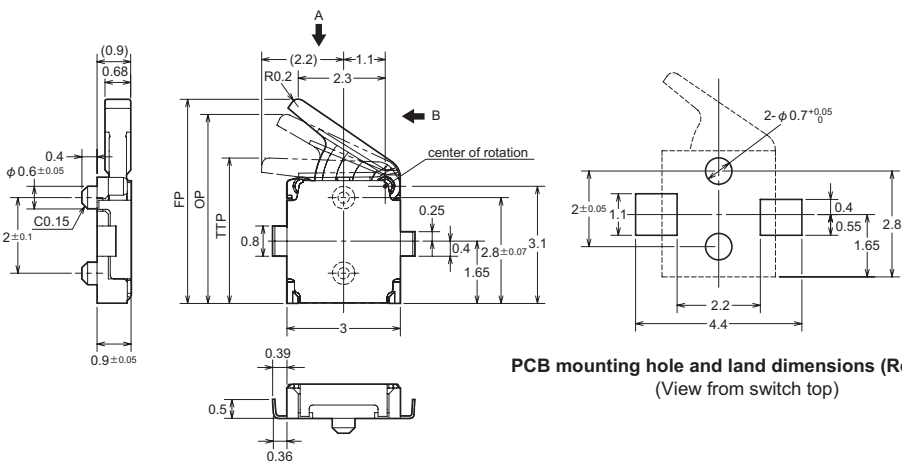

PCB mounting hole and land dimensions (Reference)  
(View from switch top)

Long Lever Models

Model	D3SH-□□ R1 D3SH-□□ L1
Operating force (OF) max.	0.24N {24 gf}
Free position (FP)	5.9 ± 0.3 mm
Operating position (OP)	5.4 ± 0.3 mm
Total travel position (TTP)	3.8 ± 0.2 mm

Right operating - without Boss

D3SH-□ 0R1

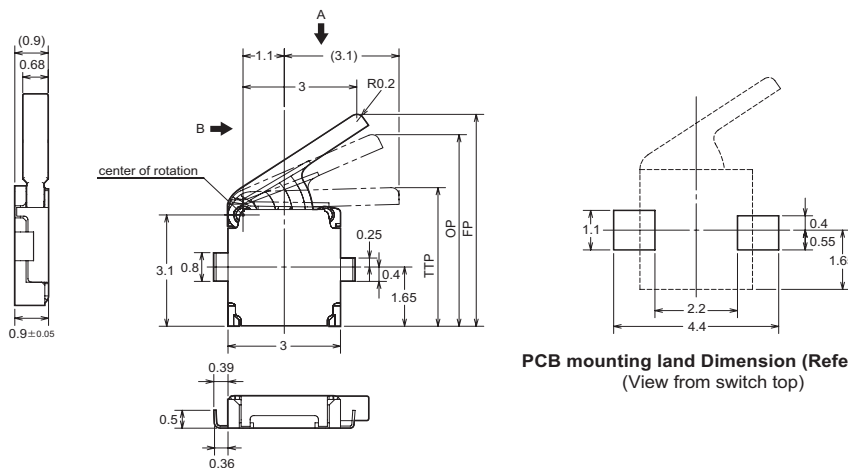

PCB mounting land Dimension (Reference)  
(View from switch top)

Left operating - without Boss

D3SH-□ 0L1

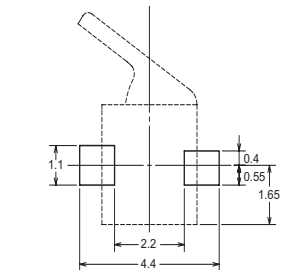
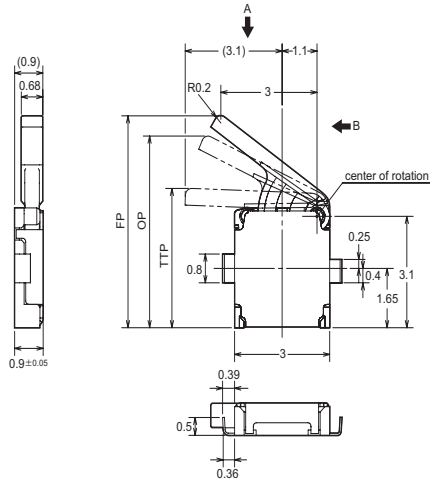

PCB mounting land Dimension (Reference)  
(View from switch top)

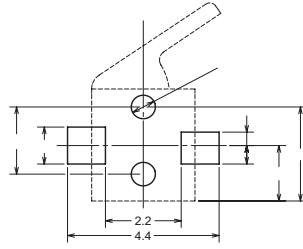
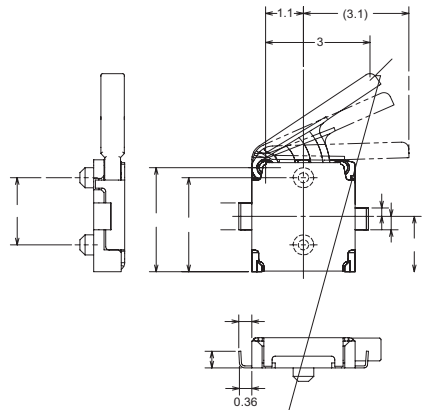

PCB mounting hole and land dimensions (Reference)  
(View from switch top)

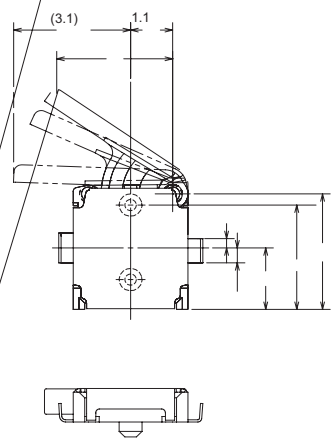

# Precautions

## ■ Caution

### Electrical Ratings

Confirm the contact load in order to select an appropriate switch rating.

Do not apply an excessive electrical load to the contacts, otherwise the contacts may weld, resulting in a short circuit or burning.

### Terminal Connection

Do not use flow soldering or hand soldering to solder terminals.

Conduct reflow soldering within the range shown in the terminal temperature profile below. Some reflow soldering devices have extremely high peak values. Do a test in advance to confirm proper soldering conditions.

Do not conduct reflow soldering more than twice. Also provide a time interval of at least five minutes between the first and second reflow soldering processes to allow the Switch to return to room temperature. Heating the Switch continuously (without an interval) may cause the edges of the Switch to melt and degrade the characteristics.

When printing for a cream solder process, a 0.13-mm screen thickness is recommended.

Be sure to provide local ventilation.

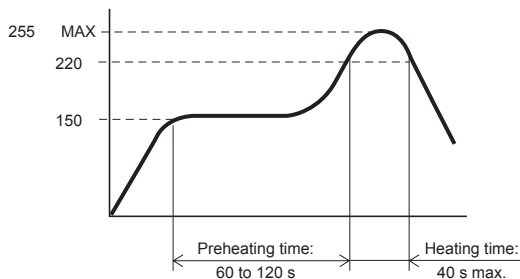

### Printed Circuit Boards

Special attention must be paid to the handling of printed circuit boards after a Switch has been mounted onto them. Airborne PCB particles may penetrate the interior of the Switch when printed circuit boards are separated by cutting. Also, do not stack printed circuit boards that have Switches mounted on them.

### Product Specification Details

This document provides only a partial list of specifications. It is recommended that you request complete drawings and specifications prior to purchasing or using the product.

## ■ Correct Use

### Mounting

The cover has the same electrical potential as the COM terminal. Do not short-circuit the cover with a NO or NC terminal when mounting the cover.

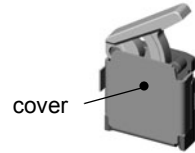

Be careful of the following points. Incorrect handling may lead to insufficient actuator return, Switch damage, or reduced durability.

- Set the operating body in line with the direction of the actuator movement, and make sure that the operating body is completely separate from the actuator when the Switch is in the free position (FP). When the actuator is operated from the crosswise direction of the Switch, make sure that the corner of the operating body has a minimum radius of R1.

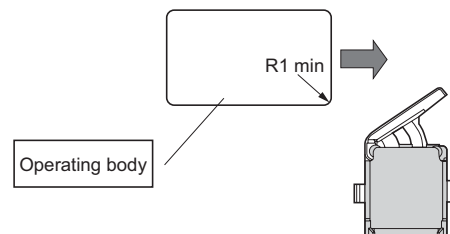

- Set the Switch stroke to 70% to 100% of the overtravel (the difference between the operating position and the total travel position).
- Do not subject the Switch to operations that involve strong impact.
- Do not use the Switch as a stopper.
- Do not apply excessive loads to the cover or operate the actuator from a direction other than a specified operating direction.
- Do not use an adhesive to secure the Switch.

A lubricant is used in the Switch. Some of the lubricant may seep out because the Switch does not have an airtight construction. Consider this possibility with respect to the usage conditions when designing or using the Switch.

### Application Environment

Do not use the Switch in locations that are subject to toxic gas, silicon, excessive dust, excessive dirt, high temperatures, high humidity, sudden temperature changes, water splashes, or oil splashes. Otherwise, damage resulting by faulty contact of the Switch contacts, corrosion, or other causes, or other functional faults may occur.

### Insulation and Wiring

Be sure that the installation conditions provide a sufficient insulation distance between Switch terminals and other metal parts, lands, etc.

### Cleaning

The Switch does not have an airtight construction, and it must not be cleaned with cleaning fluids. Malfunctions may occur if the cleaning fluid penetrates the interior of the Switch together with flux or foreign matter from the surface of the PCB.

### Confirmation with Actual Equipment

Be sure to confirm the quality of the product under the load and environmental conditions that will be used during actual applications.

## ■ RoHS Directive Compliance

Models that are indicated as being RoHS compliant are free of the following six substances.

Lead	: 1,000 ppm max.
Mercury	: 1,000 ppm max.
Cadmium	: 100 ppm max.
Hexavalent chromium	: 1,000 ppm max.
PBB	: 1,000 ppm max.
PBDE	: 1,000 ppm max.

## OMRON Switches for Integration in Machinery

### Miniature Basic Switches (V-size)

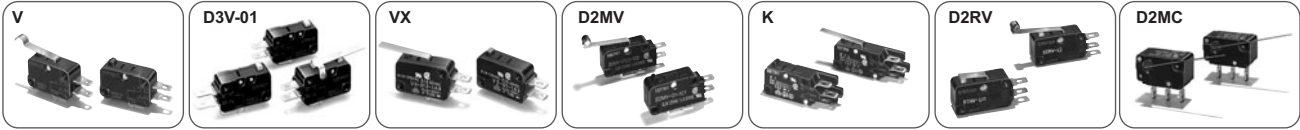

### Subminiature Basic Switches (S-size)

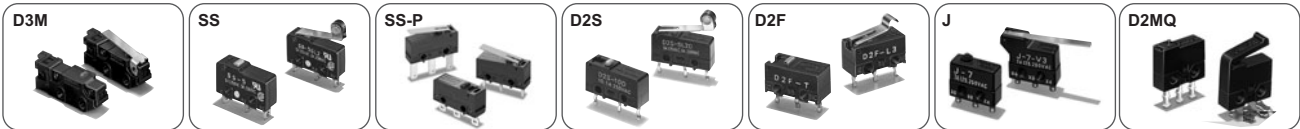

### Ultra Subminiature Switches (J-size)

### Sealed Basic Switches



### Door Switches



### Miniature Detection Switches

### Surface Mount Detection Switch



**ALL DIMENSIONS SHOWN ARE IN MILLIMETERS.**

To convert millimeters into inches, multiply by 0.03937. To convert grams into ounces, multiply by 0.03527.

Cat. No. B112-E1-01 **In the interest of product improvement, specifications are subject to change without notice.**

**OMRON Corporation**

Electronic Components Company

Switch Division

Detection Switch Department

Shiokoji Horikawa, Shimogyo-ku,

Kyoto, 600-8530 Japan

Tel: (81)75-344-7096/Fax: (81)75-344-7188

UTL : <http://www.omron.com/ecb/>

Printed in Japan  
0609-1M (0609) (W)