

Low Cost RS485 and RS422 Transceivers

Functional Diagram

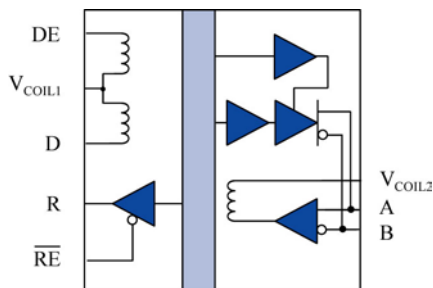

IL3185

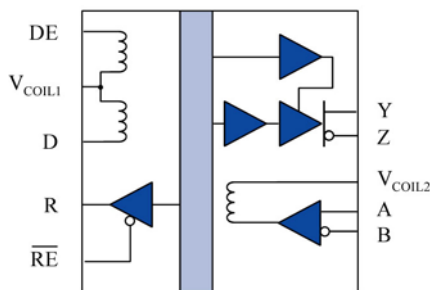

IL3122

IL3185 Truth Table

V _(A-B)	DE	D	R	RE	Mode
≥ 200 mV	H	H	H	L	Drive
≤ -200 mV	H	L	L	L	Drive
≥ 200 mV	L	X	H	L	Receive
≤ -200 mV	L	X	L	L	Receive
X	X	X	Z	H	X

Z = High Impedance X = Irrelevant

IL3122 Receiver

RE	R	V _(A-B)
H	Z	X
L	H	≥ 200 mV
L	L	≤ -200 mV

IL3122 Driver

DE	D	V _(Y-Z)
L	X	Z
H	H	≥ 200 mV
H	L	≤ -200 mV

Selection Table

Model	Full/Half Duplex	No. of Devices Allowed on Bus	Data Rate Mbps	Fail-Safe
IL3185	half	32	5	yes
IL3122	full	32	5	yes

Features

- 3.3 V / 5 V Input Supply Compatible
- 2500 V_{RMS} Isolation (1 minute)
- 20 kV/μs Typical Common Mode Rejection
- Thermal Shutdown Protection
- -40°C to +85°C Temperature Range
- 16-pin SOIC Package
- UL1577 Approval (pending)
- IEC 61010-2001 Approval
- ±15 kV ESD Protection

Applications

- High Node Count Networks
- P.O.S. Systems
- Security Networks
- Building Environmental Controls
- Industrial Control Networks
- Gaming Systems
- Factory Automation

Description

The IL3185 and IL3122 are galvanically isolated, differential bus transceivers designed for bidirectional data communication on balanced transmission lines. Isolation is achieved through patented* IsoLoop technology. The IL3185 delivers at least 1.5 V across a 54 Ω load and the IL3122 at least 2 V across a 100 Ω load, which allows better data integrity over longer cable lengths. These devices are also compatible with 3.3 V input supplies, allowing interface to standard microcontrollers without the need for additional level-shifting components.

Both the IL3185 and IL3122 have current limiting and thermal shutdown features to protect against output short circuits and bus contention situations which may cause excessive power dissipation. The receivers also incorporate a “fail-safe if open” design which ensures a logic high on R if the bus lines are disconnected or “floating.”

A 16 pF capacitor (C_{Boost}, page 9) must be placed across the current limit resistor to ensure the full specified performance.

IsoLoop® is a registered trademark of NVE Corporation.

*U.S. Patent number 5,831,426; 6,300,617 and others.

Absolute Maximum Ratings

Operating at absolute maximum ratings will not damage the device. However, extended periods of operation at the absolute maximum ratings may affect performance and reliability.

Parameters	Symbol	Min.	Typ.	Max.	Units	Test Conditions
Storage Temperature	T_s	-65		150	°C	
Ambient Operating Temperature	T_A	-40		85	°C	
Voltage Range at A or B Bus Pins		-7		12	V	
Supply Voltage ⁽¹⁾	V_{DD1}, V_{DD2}	-0.5		7	V	
Digital Input Voltage		-0.5		$V_{DD}+0.5$	V	
Digital Output Voltage		-0.5		$V_{DD}+1$	V	
ESD Protection		±15			kV	
Input Current	I_{IN}	-25		+25	mA	

Note 1. All voltage values are with respect to network ground except differential I/O bus voltages.

Recommended Operating Conditions

Parameters	Symbol	Min.	Typ.	Max.	Units	Test Conditions
Supply Voltage	V_{DD1} V_{DD2}	3.0 4.5		5.5 5.5	V	
Ambient Operating Temperature	T_A	-40		85	°C	
Input Voltage at any Bus Terminal (separately or common mode)	V_I V_{IC}			12 -7	V	
Input Threshold for Output Logic High	I_{INH}		1.5	0.8	mA	
Input Threshold for Output Logic Low	I_{INL}	5	3.5		mA	
Differential Input Voltage ⁽²⁾	V_{ID}			+12/-7	V	
High-Level Output Current (Driver)	I_{OH}	-60		60	mA	
High-Level Digital Output Current (Receiver)	I_{OH}	-8		8	mA	
Low-Level Output Current (Driver)	I_{OL}	-60		60	mA	
Low-Level Digital Output Current (Receiver)	I_{OL}	-8		8	mA	
Ambient Operating Temperature	T_A	-40		85	°C	
Digital Input Signal Rise and Fall Times	t_{IR}, t_{IF}			1	µs	

Insulation Specifications

Parameters	Symbol	Min.	Typ.	Max.	Units	Test Conditions
Creepage Distance (external)		8.077			mm	
Barrier Impedance			$>10^{14} \parallel 7$		$\Omega \parallel \text{pF}$	
Leakage Current			0.2		µA	240 V_{RMS} , 60 Hz

Safety Approvals

IEC61010-2001

TUV Certificate Numbers: N1502812, N1502812-101

Classification: Reinforced Insulation

Model	Package	Pollution Degree	Material Group	Max. Working Voltage
IL3122E, IL3185E	SOIC (0.3")	II	III	300 V_{RMS}

UL 1577

Rated 2500 V_{RMS} for 1 minute
Component Recognition program File #: E207481

Electrostatic Discharge Sensitivity

This product has been tested for electrostatic sensitivity to the limits stated in the specifications. However, NVE recommends that all integrated circuits be handled with appropriate care to avoid damage. Damage caused by inappropriate handling or storage could range from performance degradation to complete failure.

IL3285 Pin Connections

1	V _{DD1}	Input power supply
2	GND ₁	Ground return for V _{DD1}
3	R	Output data from bus
4	\overline{RE}	Read enable (if RE is high, R is high impedance)
5	DE	Drive enable
6	V _{COIL1}	Coils for DE and D (connect to V _{DD1})
7	D	Data input to bus
8	GND ₁	Ground return for V _{DD1}
9	GND ₂	Ground return for V _{DD2}
10	NC	No internal connection
11	V _{DD2}	Output power supply
12	A	Non-inverting bus line
13	B	Inverting bus line
14	NC	No internal connection
15	GND ₂	Ground return for V _{DD2}
16	V _{COIL2}	Coil for R (connect to V _{DD2})

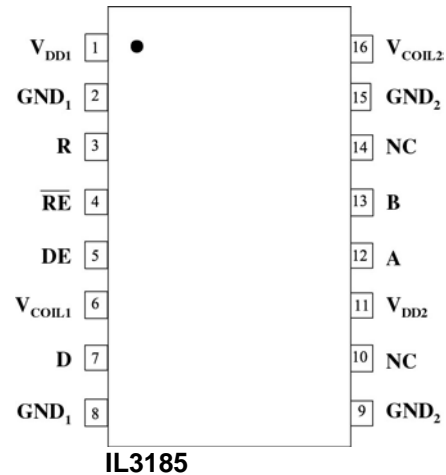

IL3185

IL3222 Pin Connections

1	V _{DD1}	Input power supply
2	GND ₁	Ground return for V _{DD1}
3	R	Output data from bus
4	\overline{RE}	Read enable (if RE is high, R is high impedance)
5	DE	Drive enable
6	V _{COIL1}	Coils for DE and D (connect to V _{DD1})
7	D	Data input to bus
8	GND ₁	Ground return for V _{DD1}
9	GND ₂	Ground return for V _{DD2}
10	Y	Non-inverting driver bus line
11	V _{DD2}	Output power supply
12	Z	Inverting driver bus line
13	B	Inverting receiver bus line
14	A	Non-inverting receiver bus line
15	GND ₂	Ground return for V _{DD2}
16	V _{COIL2}	Coil for R (connect to V _{DD2})

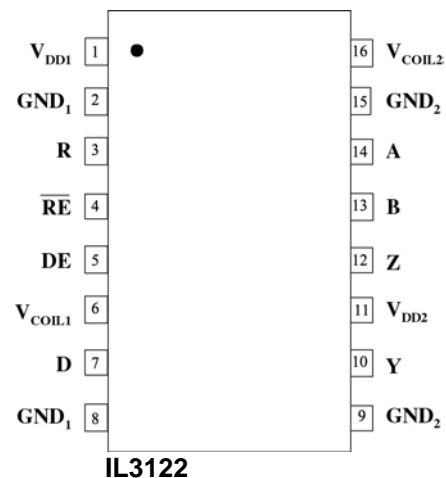

IL3122

Driver Section

Electrical specifications are T_{min} to T_{max} unless otherwise stated.

Parameters	Symbol	Min.	Typ.	Max.	Units	Test Conditions
Output voltage				V_{DD}	V	$I_O = 0$
Differential Output Voltage	$ V_{OD1} $			V_{DD}	V	$I_O = 0$
Differential Output Voltage	$ V_{OD2} $	2	3		V	$R_L = 100 \Omega$, $V_{DD} = 5 V$
Differential Output Voltage ⁽⁶⁾	V_{OD3}	1.5	2.3		V	$R_L = 54 \Omega$, $V_{DD} = 5 V$
Change in Magnitude ⁽⁷⁾ of Differential Output Voltage	$\Delta V_{OD} $			± 0.2	V	$R_L = 54 \Omega$ or 100Ω
Common Mode Output Voltage	V_{OC}			3	V	$R_L = 54 \Omega$ or 100Ω
Change in Magnitude ⁽⁷⁾ of Common Mode Output Voltage	$\Delta V_{OC} $			0.2	V	$R_L = 54 \Omega$ or 100Ω
Output Current ⁽⁴⁾				1 -0.8	mA mA	Output disabled, $V_O = 12 V$ $V_O = -7 V$
High Level Input Current	I_{IH}			0.8	mA	
Low Level Input Current	I_{IL}	5	3.5		mA	
Short-circuit Output Current	I_{OS}	60		250	mA	$-7 V < V_O < 12 V$
Supply Current ($V_{DD2} = +5 V$)	I_{DD2}		6	7	mA	No Load (Outputs Enabled)
($V_{DD1} = +5 V$)	I_{DD1}		2.5	3	mA	
Supply Current ($V_{DD1} = +3.3 V$)	I_{DD2}		1.3	2	mA	No Load (Outputs Enabled)

Switching Specifications ($V_{DD1} = +5 V$, $C_{boost} = 16pF$)

Parameters	Symbol	Min.	Typ.	Max.	Units	Test Conditions
Data Rate		5			Mbps	$R_L = 54 \Omega$, $C_L = 50 pF$
Differential Output Prop Delay	$t_p(OD)$		40	65	ns	$R_L = 54 \Omega$, $C_L = 50 pF$
Pulse Skew ⁽¹⁰⁾	$t_{sk}(P)$		6	15	ns	$R_L = 54 \Omega$, $C_L = 50 pF$
Differential Output Rise & Fall Time	$t_r(OD)$	3	12	25	ns	$R_L = 54 \Omega$, $C_L = 50 pF$
Output Enable Time to High Level	t_{pZH}		25	40	ns	$R_L = 54 \Omega$, $C_L = 50 pF$
Output Enable Time to Low Level	t_{pZL}		25	40	ns	$R_L = 54 \Omega$, $C_L = 50 pF$
Output Disable Time from High Level	t_{pHZ}		25	40	ns	$R_L = 54 \Omega$, $C_L = 50 pF$
Output Disable Time from Low Level	t_{pLZ}		25	40	ns	$R_L = 54 \Omega$, $C_L = 50 pF$
Skew Limit ⁽³⁾	$t_{sk}(LIM)$			8	ns	$R_L = 54 \Omega$, $C_L = 50 pF$
Common Mode Rejection	$ CM_H , CM_L $	15	20		kV/ μs	$V_T = 300 V_{peak}$

Switching Specifications ($V_{DD1} = +3.3 V$, $C_{boost} = 16pF$)

Parameters	Symbol	Min.	Typ.	Max.	Units	Test Conditions
Data Rate		5			Mbps	$R_L = 54 \Omega$, $C_L = 50 pF$
Differential Output Prop Delay	$t_p(OD)$		40	65	ns	$R_L = 54 \Omega$, $C_L = 50 pF$
Pulse Skew ⁽¹⁰⁾	$t_{sk}(P)$		6	20	ns	$R_L = 54 \Omega$, $C_L = 50 pF$
Differential Output Rise & Fall Time	$t_r(OD)$	3	12	25	ns	$R_L = 54 \Omega$, $C_L = 50 pF$
Output Enable Time to High Level	t_{pZH}		25	40	ns	$R_L = 54 \Omega$, $C_L = 50 pF$
Output Enable Time to Low Level	t_{pZL}		25	40	ns	$R_L = 54 \Omega$, $C_L = 50 pF$
Output Disable Time from High Level	t_{pHZ}		25	40	ns	$R_L = 54 \Omega$, $C_L = 50 pF$
Output Disable Time from Low Level	t_{pLZ}		25	40	ns	$R_L = 54 \Omega$, $C_L = 50 pF$
Skew Limit ⁽³⁾	$t_{sk}(LIM)$			8	ns	$R_L = 54 \Omega$, $C_L = 50 pF$
Common Mode Rejection	$ CM_H , CM_L $	15	20		kV/ μs	$V_T = 300 V_{peak}$

Receiver Section

Electrical specifications are T_{min} to T_{max} unless otherwise stated.

Parameters	Symbol	Min.	Typ.	Max.	Units	Test Conditions
Positive-going Input Threshold Voltage	V_{IT+}			0.2	V	$-7\text{ V} < V_{CM} < 12\text{ V}$
Negative-going Input Threshold Voltage	V_{IT-}	-0.2			V	$-7\text{ V} < V_{CM} < 12\text{ V}$
Hysteresis Voltage ($V_{IT+} - V_{IT-}$)	V_{HYS}		70		mV	$V_{CM} = 0\text{ V}$, $T = 25^\circ\text{C}$
High Level Digital Output Voltage	V_{OH}	$V_{DD} - 0.2$	$V_{DD} - 0.2$		V	$V_{ID} = 200\text{ mV}$ $I_{OH} = 4\text{ mA}$
Low Level Digital Output Voltage	V_{OL}			0.8	V	$V_{IN} = -200\text{ mV}$ $I_{OL} = 4\text{ mA}$
High impedance state output current	I_{OZ}			10	μA	$0.4 \leq V_O \leq (V_{DD2} - 0.5)\text{ V}$
Line Input Current ⁽⁸⁾	I_I			1	mA	$V_I = 12\text{ V}$
				-0.8		$V_I = -7\text{ V}$
Input Resistance	r_I	12	25		k Ω	
Switching Characteristics. ($V_{DD1} = +5\text{ V}$, $C_{boost} = 16\text{ pF}$)						
Parameters	Symbol	Min.	Typ.	Max.	Units	Test Conditions
Data Rate		5			Mbps	$R_L = 54\ \Omega$, $C_L = 50\text{ pF}$
Propagation Delay ⁽⁹⁾	t_{PD}		50	85	ns	$-1.5 \leq V_O \leq 1.5\text{ V}$, $C_L = 15\text{ pF}$
Pulse Skew ⁽¹⁰⁾	$t_{SK}(P)$		10	17	ns	$-1.5 \leq V_O \leq 1.5\text{ V}$, $C_L = 15\text{ pF}$
Skew Limit ⁽³⁾	$t_{SK}(LIM)$		2	8	ns	$R_L = 54\ \Omega$, $C_L = 50\text{ pF}$
Output Enable Time to High Level	t_{PZH}		4	40	ns	$C_L = 15\text{ pF}$
Output Enable Time to Low Level	t_{PZL}		4	40	ns	$C_L = 15\text{ pF}$
Output Disable Time from High Level	t_{PHZ}		4	40	ns	$C_L = 15\text{ pF}$
Output Disable Time from Low Level	t_{PLZ}		4	40	ns	$C_L = 15\text{ pF}$
Switching Characteristics. ($V_{DD1} = +3.3\text{ V}$, $C_{boost} = 16\text{ pF}$)						
Parameters	Symbol	Min.	Typ.	Max.	Units	Test Conditions
Data Rate		5			Mbps	$R_L = 54\ \Omega$, $C_L = 50\text{ pF}$
Propagation Delay ⁽⁹⁾	t_{PD}		55	85	ns	$-1.5 \leq V_O \leq 1.5\text{ V}$, $C_L = 15\text{ pF}$
Pulse Skew ⁽¹⁰⁾	$t_{SK}(P)$		12	20	ns	$-1.5 \leq V_O \leq 1.5\text{ V}$, $C_L = 15\text{ pF}$
Skew Limit ⁽³⁾	$t_{SK}(LIM)$		4	10	ns	$R_L = 54\ \Omega$, $C_L = 50\text{ pF}$
Output Enable Time to High Level	t_{PZH}		5	10	ns	$C_L = 15\text{ pF}$
Output Enable Time to Low Level	t_{PZL}		5	10	ns	$C_L = 15\text{ pF}$
Output Disable Time from High Level	t_{PHZ}		5	10	ns	$C_L = 15\text{ pF}$
Output Disable Time from Low Level	t_{PLZ}		17	10	ns	$C_L = 15\text{ pF}$

Notes (these notes apply to both driver and receiver sections):

- Differential input/output voltage is measured at the noninverting terminal A with respect to the inverting terminal B.
- Skew limit is the maximum difference in any two channels in one device.
- The power-off measurement in ANSI Standard EIA/TIA-422-B applies to disabled outputs only and is not applied to combined inputs and outputs.
- All typical values are at V_{DD1} , $V_{DD2} = 5\text{ V}$ or $V_{DD1} = 3.3\text{ V}$ and $T_A = 25^\circ\text{C}$.
- While $-7\text{ V} < V_{CM} < 12\text{ V}$, the minimum V_{OD2} with a $54\ \Omega$ load is either $\frac{1}{2} V_{OD1}$ or 1.5 V , whichever is greater.
- $\Delta|V_{OD}|$ and $\Delta|V_{OC}|$ are the changes in magnitude of V_{OD} and V_{OC} , respectively, that occur when the input is changed from one logic state to the other.
- This applies for both power on and power off; refer to ANSI standard RS485 for exact condition. The EIA/TIA-422-B limit does not apply for a combined driver and receiver terminal.
- Includes 10 ns read enable time. Maximum propagation delay is 25 ns after read assertion.
- Pulse skew is defined as the $|t_{PLH} - t_{PHL}|$ of each channel.

Power Supplies

Both V_{DD1} and V_{DD2} must be bypassed with 47 nF ceramic capacitors. These should be placed as close as possible to V_{DD} pins for proper operation. V_{DD2} should be bypassed with an additional 10 μ F tantalum capacitor.

Operation

The IL3122 and IL3185 are current-mode devices. Changes in current flow into the input coil result in logic state changes at the output. The internal GMR sensor switches the output to logic low when current flows in the coil. A single resistor is required to limit the input coil current to the recommended 5 mA.

The absolute maximum current through any coil is 25 mA DC. The worst case logic threshold current is 5 mA. While typical threshold currents are actually less than this, NVE recommends designing a 5 mA logic threshold current in each application. Output logic high is the zero input current state.

Figure 1 shows the input response of the IL3122 and IL3185. The GMR bridge structure is designed such that the output of the isolator is logic high when no field signal is present. The output will switch to the low state with approximately 3.5 mA of coil current, and switch back to the high state when the input current falls below 1.5 mA. This allows glitch-free interface with low slew rate signals.

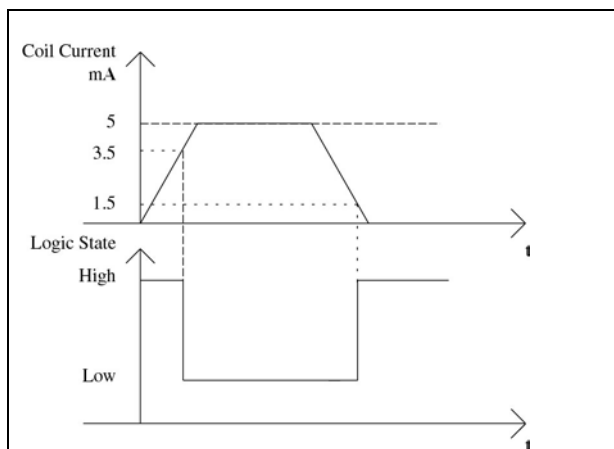

Figure 1. IL31xx Series Input Transfer Function

the sensor. This shield acts as a flux concentrator to boost the magnetic signal from the internal coil and as a shield against externally generated magnetic fields. The shield will absorb surrounding stray flux until it becomes saturated. At saturation the shield is transparent to an external applied field and the GMR sensor may react to the field. To compensate for this effect, IsoLoop devices use Wheatstone bridge structures that are only sensitive to differential magnetic fields. In addition, the IL3000 series allows several ways of enhancing magnetic field immunity. In general, applying a larger internal field will reduce the effect of an external field on the GMR sensor. Two options for enhancing external magnetic field immunity are described below.

Magnetic Field Booster Capacitor

In all applications it is possible to boost the signal seen by the GMR sensor. This can be of benefit in high temperature applications. A small capacitor (200 pF to 1 nF) placed across the current limiting resistor will effectively boost instantaneous current through the coil at the point of signal transition. The resultant magnetic field has the effect of pushing the GMR bridge output through the comparator threshold voltage with reduced propagation delay and improved pulse width distortion. The use of the capacitor gives a great deal of design headroom and can usually eliminate design concerns related to temperature range and power supply fluctuation.

Magnetic Field Immunity

All IsoLoop devices operate by imposing a magnetic field on a GMR sensor which then translates the change in field into a change in output logic state. The devices are manufactured with a magnetic shield above

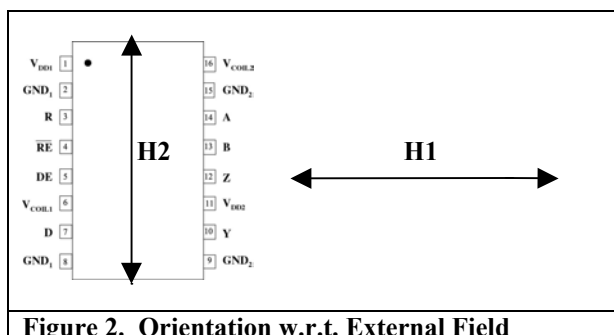

Figure 2. Orientation w.r.t. External Field

Orientation of the device with respect to the field direction

An applied field in the direction of “H1” with respect to the orientation of the device will result in worst case immunity. In this case the external field is operating in the same direction as the applied internal field. In one direction it will tend to help switching while in the other it will tend to hinder it. This can result in unpredictable switching due to external magnetic fields.

An applied field in the direction of “H2” has considerably less effect on the sensor and will result in significantly higher immunity levels as shown in Table 1.

The greatest magnetic immunity is achieved by adding the current boost capacitor across the input resistor. Very high immunity can be achieved with this method.

Method	Expected Immunity	Immunity Description
Field applied in direction H1	±20 Gauss	A DC current of 16 A flowing in a conductor 1 cm away from the device could cause disturbance
Field applied in direction H2	±70 Gauss	A DC current of 56 A flowing in a conductor 1 cm away from the device could cause disturbance
Field applied in any direction but with field booster capacitor (1 nF) in circuit	±250 Gauss	A DC current of 200 A flowing in a conductor 1 cm away from the device could cause disturbance

Table 1. Magnetic Immunity

Data Rate and Magnetic Field Immunity

In all IL3000 series applications it is easier to disrupt an isolated DC signal with an external magnetic field than it is to disrupt an isolated AC signal. Similarly, a DC magnetic field will have a greater effect on the device than an AC magnetic field of the same effective magnitude. For example, signals with pulse durations greater than 100 μ s are more susceptible to the effects of magnetic fields than those with a shorter pulse duration. For input signals greater than 1 MHz, a 1 nF current boost capacitor will provide as much as 400 Gauss immunity, while the same input capacitor might only provide 70 Gauss of immunity on a 50 kHz signal.

Applications Information

RS485 and RS422 are differential (balanced) data transmission standards for use with long distance cabling or in noisy environments. RS422 is a subset of RS485, so RS485 transceivers are also RS422 compliant. RS422 is a multi-drop standard which allows only one driver and up to 10 (assuming one unit load devices) receivers on each bus. RS485 is a true multipoint standard which allows up to 32 one-unit load devices (any combination of drivers and receivers) on each bus. To allow for multipoint operation the RS485 specification requires drivers to handle bus contention without damage. Another important advantage of RS485 is the extended common mode range (CMR) which specifies that the driver outputs and receiver inputs withstand signals that range from +12 V to -7 V. RS422 and RS485 are intended for runs as long as 4,000 feet (1200 m), so the wide CMR is necessary to handle ground potential differences as well as voltages induced in the cable by external fields.

Receiver Features

These devices utilize a differential input receiver for maximum noise immunity and common mode rejection. Input sensitivity is ± 200 mV as required by the RS422 and RS485 specifications. All the receivers include a “fail-safe if open” function that guarantees a high level receiver output if the receiver inputs are unconnected (floating). Receivers easily meet the data rates supported by the corresponding driver. IL3000 series receiver outputs have tri-state capability via the active low RE input.

Driver Features

The RS485/422 driver is a differential output device that delivers at least 1.5 V across a 54 Ω load (RS485), and at least 2 V across a 100 Ω load (RS422). The drivers feature low propagation delay skew to maximize bit width and to minimize EMI. Drivers of the IL3122 and IL3185 have tri-state capability via the active high DE input.

Cabling, Data Rate and Terminations

Cabling:

Use twisted-pair cable. This may be unshielded if the cable run is short (<10 m) and the data rate is low (<100 Kbps). Otherwise use screened cable with the shield tied to earth at one end only. Do not tie the shield to digital ground. The other end of the shield may be tied to earth via an RC network. This will prevent a DC ground loop in the shield. Using a shielded cable will minimize EMI emissions and external noise coupling to the bus.

Data Rate:

The longer the cable, the slower the data rate. The RS485 bus can transmit over 4,000 feet (1200 m) and at 10Mbps. But it cannot do both at the same time. The transducer characteristics and cable characteristics combine to act as a filter to give the general response shown in Figure 3. Other parameters such as acceptable amounts of jitter will affect the final cable length / data rate trade-off. Less jitter means better signal quality but shorter cable lengths or slower data rates. Figure 2 shows a generally accepted 30% jitter and a corresponding data rate versus cable length.

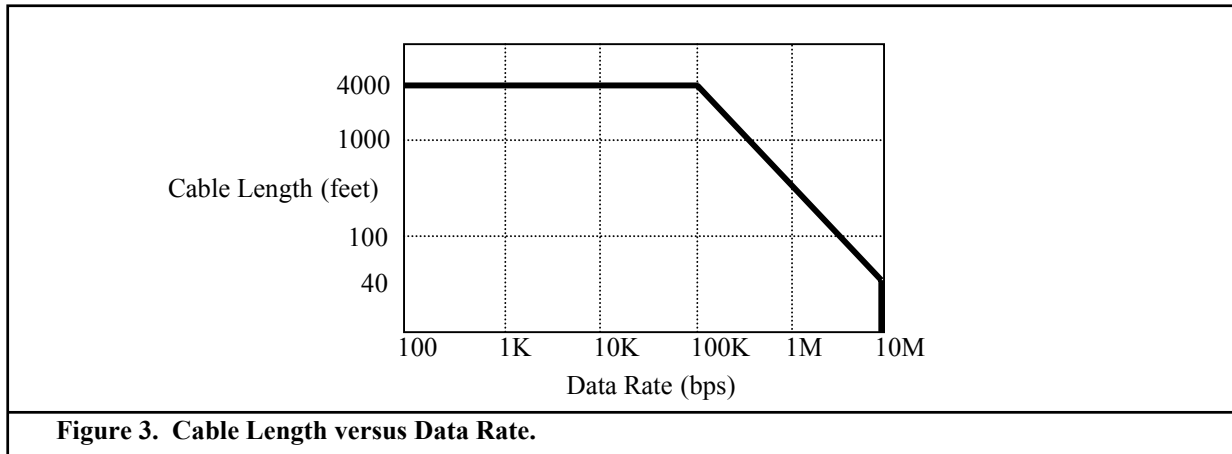

Terminations

Transmission lines should be terminated to avoid reflections which will cause data errors. In RS485 systems both ends of the bus should be terminated; not every node. In RS422 systems only the receiver end should be terminated.

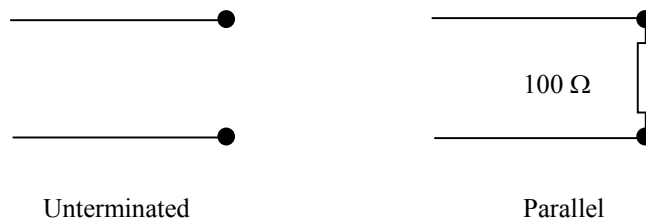

Unterminated lines are only suitable for very low data rates and very short cable runs, otherwise line reflections cause problems. Parallel terminations are the most popular. They allow high data rates and excellent signal quality.

Occasionally in noisy environments fast pulses or noise appearing on the bus lines can cause problems. One way of overcoming this without adding delay into the circuit is to put a series resistor in the bus line. Depending on the power supply the resistor should be between 300 Ω (3 V supply) and 500 Ω (5 V supply). Proper termination is imperative when using IL3185 and IL3122 to minimize reflections.

Typical Coil Connections

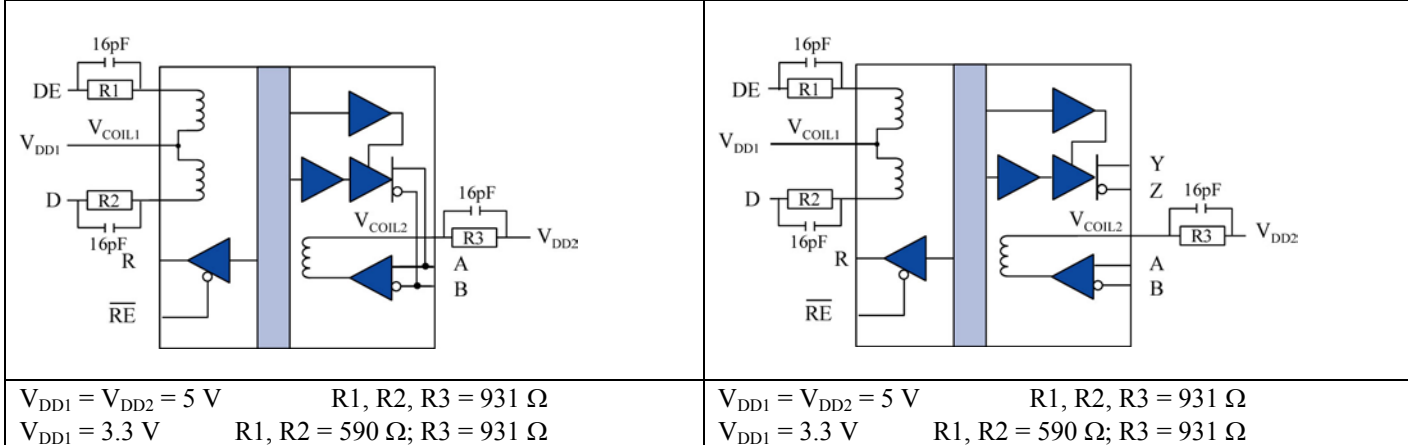

Soldering Profile

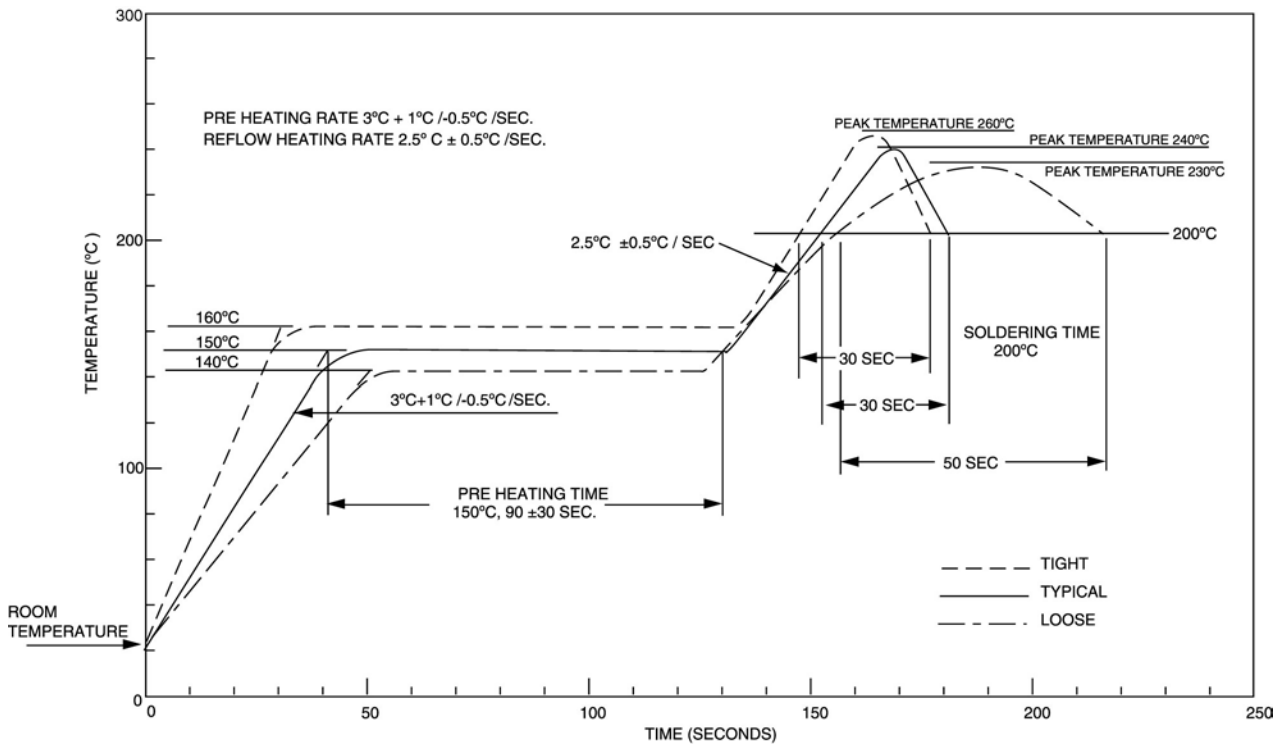

Package Drawings, Dimensions and Specifications

0.3" 16-pin SOIC

Dimensions in inches

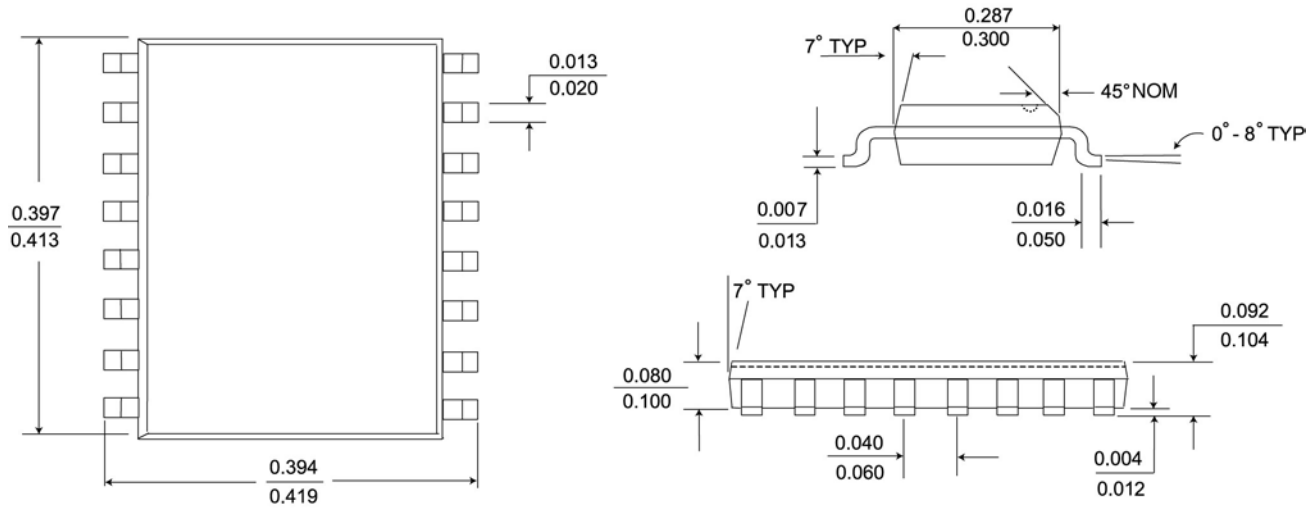

Pin 1 is identified by either an indent or a white dot.

Ordering Information and Valid Part Numbers

IL 3185 E TR13

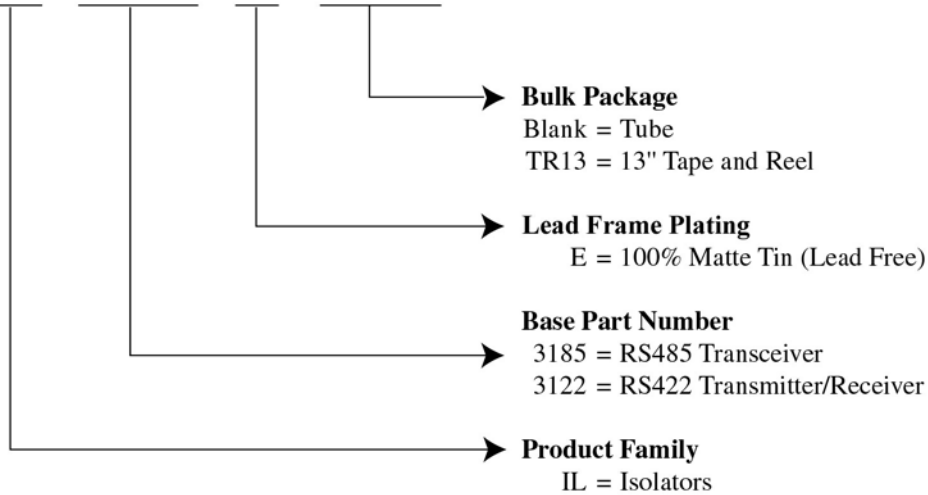

Valid Part Numbers

- IL3185E
- IL3185E TR13
- IL3122E
- IL3122ETR13

Revision History

ISB-DS-001-IL3185/22-B

Changes

1. Capacitor Information added on page 1
2. Input Signal Rise/Fall times changed from 10 μ s to 1 μ s
3. Typical coil formations show C_{Boost}
4. Switching characteristics show $C_{\text{Boost}} = 16$ pF

ISB-DS-001-IL3185/22-A

Initial Release

About NVE

NVE is an ISO 9001 Certified Company.

NVE Corporation is a high technology components manufacturer having the unique capability to combine leading edge Giant Magnetoresistive (GMR) materials with integrated circuits to make high performance electronic components. Products include Magnetic Field Sensors, Magnetic Field Gradient Sensors (Gradiometer), Digital Magnetic Field Sensors, Digital Signal Isolators and Isolated Bus Transceivers.

NVE is a leader in GMR research and in 1994 introduced the world's first products using GMR material, a line of GMR magnetic field sensors that can be used for position, magnetic media, wheel speed and current sensing.

NVE is located in Eden Prairie, Minnesota, a suburb of Minneapolis. Please visit our Web site at www.nve.com or call 952-829-9217 for information on products, sales or distribution.

NVE Corporation
11409 Valley View Road
Eden Prairie, MN 55344-3617 USA
Telephone: (952) 829-9217
Fax: (952) 829-9189
Internet: www.nve.com
e-mail: isoinfo@nve.com

The information provided by NVE Corporation is believed to be accurate. However, no responsibility is assumed by NVE Corporation for its use, nor for any infringement of patents, nor rights or licenses granted to third parties, which may result from its use. No license is granted by implication, or otherwise, under any patent or patent rights of NVE Corporation. NVE Corporation does not authorize, nor warrant, any NVE Corporation product for use in life support devices or systems or other critical applications, without the express written approval of the President of NVE Corporation.

Specifications shown are subject to change without notice.

ISB-DS-001-IL3185/22-B

January 19, 2006