

成型尺寸	公差
5mm 以下	±0.2
5~20mm	±0.3
20~40mm	±0.4
40~60mm	±0.5
60~100mm	±0.8
100mm 以上	±1.0

REVISIONS			
REV	DESCRIPTION	DATE	BY

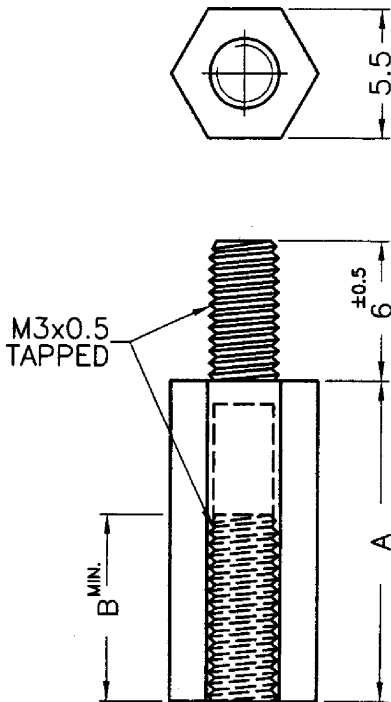

PART NO.	A	B
TP-5	5.0	3.0
TP-6	6.0	4.0
TP-7	7.0	5.0
TP-8	8.0	6.0
TP-9	9.0	6.0
TP-10	10.0	6.0
TP-10.5	10.5	6.0
TP-11	11.0	6.0
TP-12	12.7	6.0
TP-12A	12.0	6.0
TP-13	13.0	6.0
TP-14	14.0	6.0
TP-15	15.0	6.0
TP-16	16.0	6.0

PART NO.	A	B
TP-16.5	16.5	6.0
TP-17	17.0	6.0
TP-18	18.0	6.0
TP-18.5	18.5	6.0
TP-19	19.0	6.0
TP-20	20.0	6.0
TP-21	21.0	6.0
TP-22	22.0	6.0
TP-24.5	24.5	6.0
TP-25	25.0	6.0
TP-27	27.0	6.0
TP-30	30.0	6.0
TP-33	33.0	6.0
TP-35	35.0	6.0

QMF22 Component - Plastics  
 E I DUPONT DE NEMOURS & CO INC  
 ENGINEERING POLYMERS CHESTNUT RUN PLAZA PO BOX 80713 WILMINGTON DE 19880

Wednesday, September 15, 2004

E41938

Material Designation: 101(+)(f1), 101F(+)(f1), 101L(+)(f1), E101(+)(f1), E101L(f1), 132F(+)(f1), 135F(+)(f1)  
 Product Description: Polyamide 66 (PA66), designated "Zytel" furnished as pellets.

Color	Min. Thick. (mm)	Flame Class	HWI	HAI	RTI Elec	RTI Imp	RTI Str	IEC GWIT	IEC GWFI
ALL	0.71	V-2	4	0	130	75	85	725	960
	1.5	V-2	3	0	130	75	85	750	960
	3	V-2	2	0	130	75	85	800	960
	6	V-2	2	0	130	75	85	800	960

CTI: 0

HVTR: 0

D495: 6

Dielectric Strength (kV/mm): 13

Volume Resistivity (10<sup>12</sup>ohm-cm): 14

IEC Ball Pressure (°C):

Dimensional Stability(°C):

ISO Tensile Strength (MPa):

ISO Flexural Strength (MPa):

ISO Heat Deflection (°C):

ISO Tensile Impact (kJ/m<sup>2</sup>):

ISO Izod Impact (kJ/m<sup>2</sup>):

ISO Charpy Impact (kJ/m<sup>2</sup>):

(+) Virgin and regrind up to 50% by weight inclusive, have the same basic material characteristics.

(f1) Suitable for outdoor use with respect to exposure to Ultraviolet Light, Water Exposure and Immersion in accordance with UL 746C.

NOTE (1) Material designations that are color pigmented may be followed by suffix letters and numbers. (2) Material designations may be prefixed by "ZYT" or "MIN" or "ZEN" or "DEL" or "CRA" or "RYN".

Report Date: 7/29/1996

Underwriters Laboratories Inc®

UL94 small-scale test data does not pertain to building materials, furnishings and related contents. UL 94 small-scale test data is intended solely for determining the flammability of plastic materials used in components and parts of end-product devices and appliances, where the acceptability of the combination is determined by ULL.



<p>康揚企業股份有限公司          KANG YANG HARDWARE ENTERPRISE CO., LTD.          東莞康揚塑膠五金電子廠          DONG GUAN KANG YANG PLASTIC HARDWARE COMPANY          康哲電腦配件(吳江)有限公司          KANG CHE COMPUTER COMPONENTS(WUJIANG) CO.,LTD.</p>		TITLE	塑膠銅柱	產品規格圖面
		MATERIAL	NYLON 66 UL94V-2	DATE
PART NUMBER		FINISH	COLOR	DRAWN
SEE ABOVE			NATURAL	JASON
DRAWING NUMBER		CHECK	UNLESS OTHERWISE SPECIFIED TOLERANCE	APPROVED
TP-H			SEE ABOVE	Kary
SIZE	SCALE	UNIT	REV	
A4	NONE	mm	C	