

FEATURES

- Ultra-low profile 1.4 mm .055 inch They allow products to be slimmer
- The original coil spring-activated mechanism yields a light operating force (max. 30gf) and a high overtravel to facilitate installation.
- The coil spring serves as the contact and a high contact reliability is achieved by the more than adequate contact force and wiping effect.
- Detecting from vertical and horizontal directions is possible. The actuator is rotated by the rotary shaft in the body.



• 2 types of SMD terminal is available. The low-profile type is mounted by making square holes at the edges of the printed circuit boards, resulting in a low profile.

• Gold-plated contact type is available for low level circuit (10µA 5V DC to 10mA 5V DC)

TYPICAL APPLICATIONS

- IC card and other electronic money-related products.
- CD-ROM drivers
- Cellular phones
- MD
- Video cameras
- Digital still camera
- Headphone stereo

PRODUCT TYPES

Detection direction	Packing style	Contact type	Standard type	Low Profile type	
				Standard embossed tape packing	Upside-down embossed tape packing
Right angle 	Embossed tape (3000 pcs/reel)	Silver-plated	ABC1111P	ABC1121P	ABC1121P1
		Gold-plated	ABC1111P61	ABC1121P61	ABC1121P161
Left angle 		Silver-plated	ABC1112P	ABC1122P	ABC1122P1
		Gold-plated	ABC1112P61	ABC1122P61	ABC1122P161

CONTACT ARRANGEMENT

1 Form A

MOUNTING VIEW

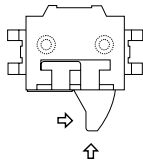
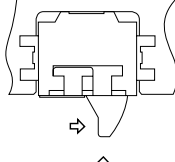
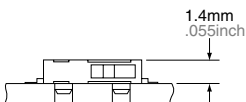
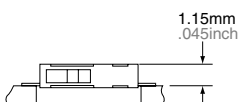
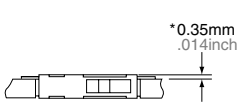
	Standard type	Low profile type	
		Standard embossed tape packing	Upside-down embossed tape packing
TOP VIEW			
Mounting part layout			

Note) * The mounting height of 0.35 mm .014 inch indicated by the asterisk applies when the standard embossed tape packages are used, that is to say, when the switches have been mounted using embossed tape packages on which the switches are encapsulated after their fronts and backs have been reversed.

SPECIFICATIONS

1. Contact rating

Silver-plated	100 μ A 5V DC to 10 mA 5V DC (resistive load)
Gold-plated	10 μ A 5V DC to 10 mA 5V DC (resistive load)

2. Characteristics

	Silver-plated	Gold-plated
Electrical life	Min. 10 ⁵ (100 μ A 5V DC to 10 mA 5V DC contact opening 20 cpm)	Min. 10 ⁵ (10 μ A 5V DC to 10 mA 5V DC contact opening 20 cpm)
Insulation resistance	Min. 100 M Ω (by 100V DC insulation resistance meter)	
Dielectric strength	100 Vrms for 1 min. (Between uncontinuous terminals)	
Contact resistance (initial)	Max. 1 Ω (by voltage drop at 10 mA 5V DC)	Max. 3 Ω (by voltage drop at 10 mA 5V DC)
Contact resistance	14.7 m/s ² {1.5G} 10 to 500Hz (Contact opening: max. 1 msec.)	
Shock resistance	294 m/s ² {30G} (Contact opening: max. 1 msec.)	
Allowable operating speed	30 to 300mm/s	
Allowable operating frequency	60 times/min. (at no load)	
Ambient temperature	-25 to 60°C -13 to 140°F Not freezing nor condensing	-25 to 80°C -13 to 176°F Not freezing nor condensing

3. Operating characteristics

Item	Standard type	Low profile type
Free position (F.P.) (mm inch)	4.9 \pm 0.2 .193 \pm .008	7.1 \pm 0.2 .280 \pm .008
Operating position (O.P.) (mm inch)	4.4 \pm 0.3 .173 \pm .012	6.6 \pm 0.3 .260 \pm .012
Total travel position (T.T.P.) (mm inch)	2.6 \pm 0.2 .102 \pm .008	4.8 \pm 0.2 .189 \pm .008
Operating force (N)	0.29 (30gf) max. by 5.0 mm .197 inch from the bottom of the switch	0.29 (30gf) max. by 2.8 mm .110 inch from the center of the positioning projection

DIMENSIONS

mm inch

1. Standard type

Right angle

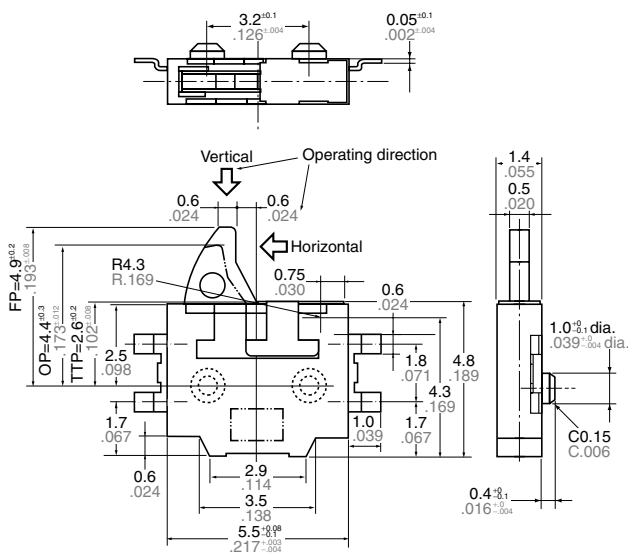

Circuit construction
N.O.

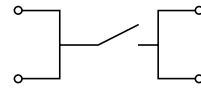

PC board pattern

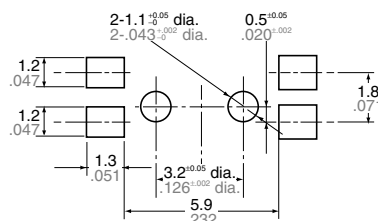

Left angle

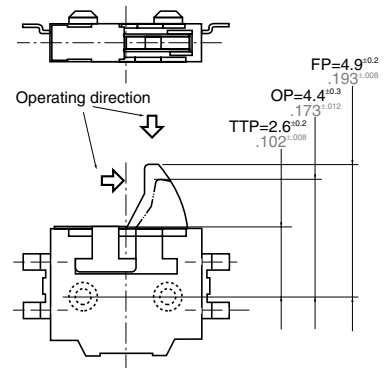

2. Low profile type

Right angle

mm inch

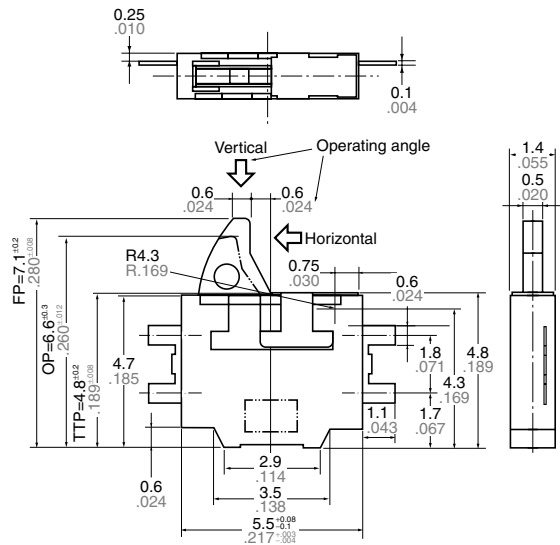

Circuit construction

N.O.

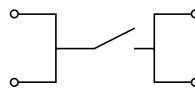

PC board pattern

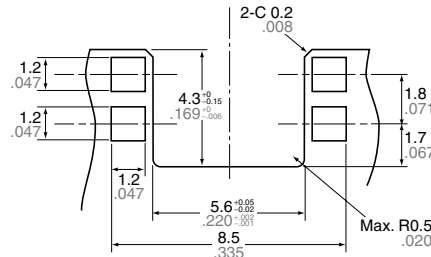

Left angle

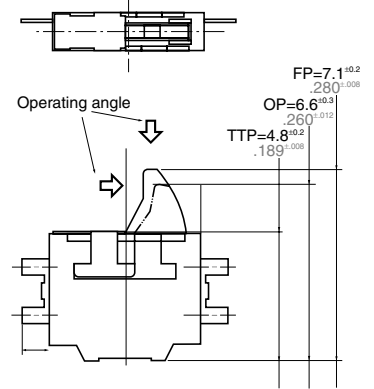

NOTES

1. Mounting

The positioning of the switch should be such that the pushbutton for the switch should not directly apply force to the operating section in the free condition. During both mounting and operation, care must be taken to protect the pushbutton from excessive stress, as this may cause malfunctioning. During mounting, the insulation distance between ground and each terminals/cover should be confirmed as sufficient.

2. Soldering

For manual soldering; Iron tip temperature max. is 320°C 608°F and soldering should be completed within 3 seconds. For reflow soldering; Perform soldering reflow at a peak surface temperature of the PC board not to exceed 245°C 473°F. For cream soldering; Screen thickness is recommended between 0.15 to 0.20 mm .006 to .008 inch. During soldering, care should be taken not to apply excessive stress to the terminals as the resulting deformation may cause malfunctioning. Excessively high solder tab temperature and soldering iron wattage should also be avoided as these factors may harm switching performance. As this switch is thin, using flux should be avoided for the reason of the flux may come inside of the switch and cause damage.

3. Switch operations

The installation position of the activating unit which operates the switch should be set at a distance of 2.8 to 3.9 mm .110 to .154 inch from the center of the positioning projection in the case of the standard type and at a distance of 5.0 to 6.1 mm .197 to .240 inch from the bottom of the switch in the case of the low-profile type. Avoid using the switch as a stopper since it may cause trouble with the operations. When using the switch to operate in the sideways direction, ensure that the corner roundness of the operating unit is more than R1.

4. Environment

These switches do not have a sealed construction. As such, the construction of the equipment in which the switches are to be installed should be given careful consideration when the switches are to be used in locations where corrosive gases, silicon or other substances which will adversely affect the contacts are used, where there is a high concentration of dust or where the switches may be exposed to condensation or water. Using switches in locations like these may cause malfunctioning. Avoid using this switch in high-temperature, high-humidity or condensation-forming environments and avoid allowing

droplets of water to remain on the switch or come into contact with it. These conditions may interfere with the performance of the switch (resulting in short-circuiting, migration, etc.). Use the type with the gold contacts in applications involving trains, aircraft, motor vehicles or medical equipment where the switch must satisfy safety and high reliability requirements.

5. Quality check under actual loading conditions

To improve reliability, check the switch under actual loading conditions.

6. Others

Consult with us if this switch is to be used outside its ratings.