

WE'RE BIG ON BRUSHLESS™ WE'RE BIG ON BRUSHLESS™ WE'RE BIG ON BRUSHLESS™ WE'RE BIG ON BRUSHLESS™

Tech Bulletin

5.7" (145mm) BLDC Thru Flow Blower

400 WATT, 240 VOLT

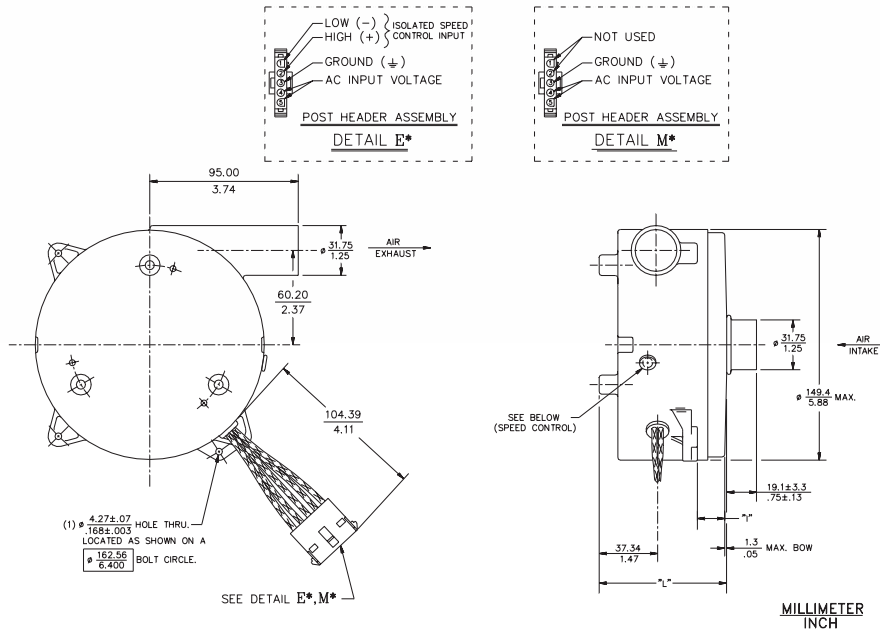

Blower Data	Unit of Measure	Part Number	
		Standard Flow	
		117629 E*	117630 E*
Stages		1	2
Vacuum, Max. (Sealed Vacuum)	in. H ₂ O	28	47
	mBar	69	117
Pressure, Max. (Sealed Pressure)	in. H ₂ O	31	50
	mBar	77	124
Flow Rate, Max. (Open Flow)	CFM	67	65
	L/sec	32	31
Length (Dimension "I" above)	inches	.69	1.60
	mm	17.53	40.64
Length (Dimension "L" above)	inches	3.21	4.12
	mm	81.53	104.65

Typical Performance Points

Air Flow	Pressure		
0 CFM	in. H ₂ O	31.1	50.5
10 CFM	in. H ₂ O	26.8	45.4
20 CFM	in. H ₂ O	23.8	40.9
30 CFM	in. H ₂ O	20.5	33.7
40 CFM	in. H ₂ O	15.8	25.3
50 CFM	in. H ₂ O	10.0	16.0
60 CFM	in. H ₂ O	4.4	6.46
70 CFM	in. H ₂ O		

*These part numbers are available through AMETEK Rotron distributors. See page 54 for distributor information.

NOTES:

Nominal input voltage: 240 Volts AC RMS +/- 10%, 60Hz

Input current: 5 amps AC RMS maximum

Temperature: Working Air: 0° C to 50° C, Ambient Air: 0° C to 50° C, Storage Air: -40° C to 85° C

Dielectric Testing: 1500 volts AC RMS 60Hz applied for one second between input pins and ground, 3mA leakage max.

Speed Control: E (Electrical): Pulse Width Modulation or Analog input voltage (User Supplied), 0 to 10 Volts DC Nominal, 10mA Maximum, 3 to 15 volts DC Maximum. Access to sensitivity adjustment for 0-10 VDC speed control. (Ref. pin connection)

M (Mechanical): A potentiometer is available for speed control of the blower. The potentiometer can be preset for a specific speed. Access to speed adjustment.

5.7" (145mm) BLDC Thru Flow Blower

400 WATT, 240 VOLT

HIGH-VOLTAGE BLOWERS

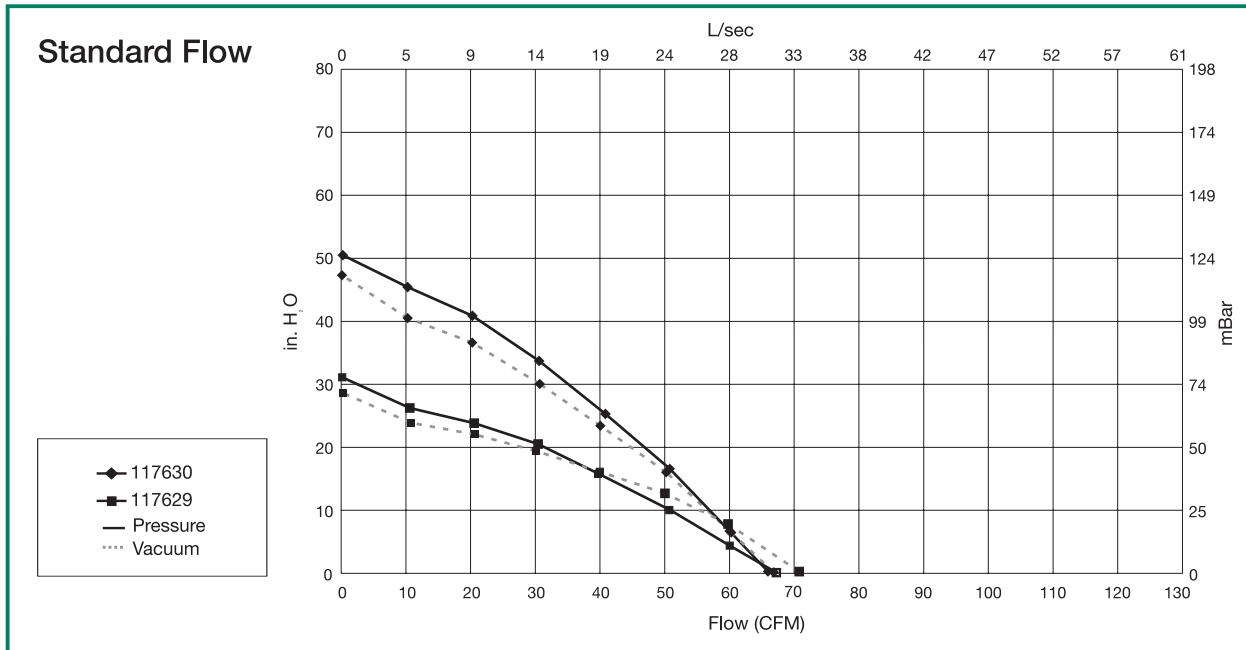

Regulatory Agency Certification: Underwriters Laboratories, Inc. is qualified per UL507 under File E-94403; Canadian Standards Association is qualified per C22.2#113 under File LR 43448.

Miscellaneous: Intake & exhaust tubes, all cooling ducts and vents must not be obstructed. Intake and exhaust are free of grease, oil, or foreign particles. Amp housing #350809-1 (to be supplied by customer), mates with post header assembly.

This document is for informational purposes only and should not be considered as a binding description of the products or their performance in all applications. The performance data on this page depicts typical performance under controlled laboratory conditions, data is corrected to 0.075 lb./ft³ air density (29.92" Hg @ 70° F). Actual performance will vary depending on the operating environment and application. AMETEK Rotron products are not designed for use with volatile, hazardous or corrosive gases. Blower housings are not sealed, slight air/gas leakage will occur. AMETEK Rotron products are not designed for and should not be used in medical life support applications. AMETEK reserves the right to revise its products without notification.