

DO NOT SCALE THIS DRAWING

REVISIONS				
SYM	DESCRIPTION	DATE	E.C.O. NO.	APPR.
	OFFICIAL ENG. RELEASE TO MFG.			
U	REDESIGNED & REDRAWN	10-7-88	35895	DET
V	ITEM 7 WAS 31-10059 & ITEM 2 WAS 31-12003-1	4/1/91	38016	DR
W	CHANGED PLATE NOTE 1; REMOVED PLATE NOTES 2 & 3; ADDED PLATE LETTERS & NOTES 9 THRU 11; REMOVED 100 LB PULL NOTE.	11/1/92	39192	DR

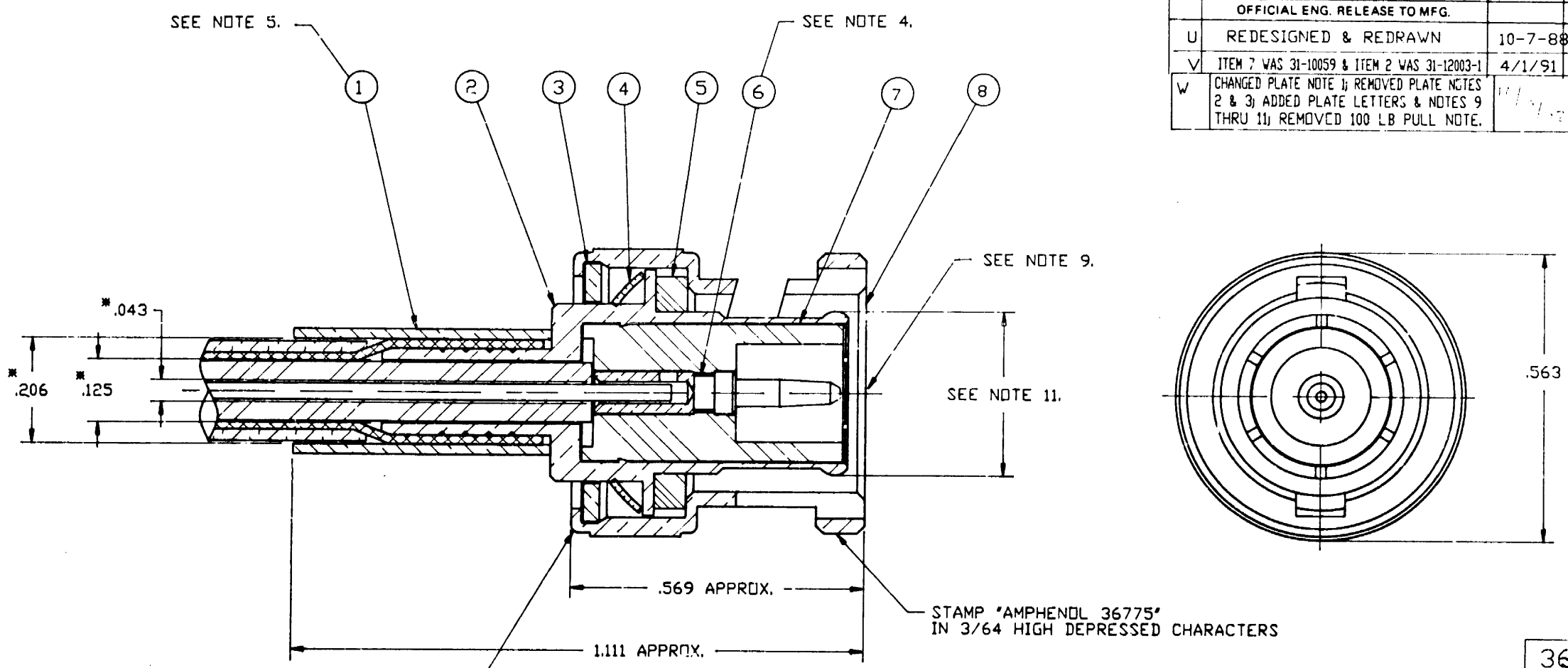

36775
DRAWING NUMBER ISSUE W

FORM OVER ALL AROUND
DO NOT BREAK THRU
PLT. SEE NOTE 9.

- NOTES:
1. PLATING MUST CONFORM TO AMPHENOL SPEC. 349-50560 CONTACT IS GOLD PLATED, ALL OTHER METAL PARTS ARE ASTROPLATED (REF).
 2. HEAT SHRINK TUBING SUPPLIED ON REQUEST.
 3. HANDLE ALL ITEMS CAREFULLY TO AVOID DAMAGING THIN SECTIONS.
 4. CUSTOMER NOTE: WHEN SOLDERING CONTACT TO CABLE, ROSIN CORE SOFT SOLDER PER QQ-S-571 Sn 60 IS RECOMMENDED. WHEN CRIMPING CONTACT TO CABLE, CRIMP WITH AMPHENOL TOOL 227-944 (M22520/5-01) AND DIE SET 227-1221-11, CAVITY 'B' (M22520/5-11, CLOSURE 'B').
 5. CRIMP WITH AMPHENOL TOOL 227-944 (M22520/5-01) AND DIE SET 227-1221-11, CAVITY 'A' (M22520/5-11, CLOSURE 'A').
 6. ASTERISK (*) INDICATES CABLE ENTRY DIMENSIONS.
 7. PACKAGE THIS CONNECTOR IN BAG 999-225. MARK PACKAGING BAG "RJ 5A 500V".
 8. U.L. RECOGNIZED ITEM - NO CHANGES ARE PERMITTED WHICH AFFECT CATALOG SPECS.
 9. MUST CONFORM TO AMPHENOL SPEC. 349-50551, SEC. 301.
 10. ITEMS 1 & 6 WILL BE PACKAGED LOOSE.
 11. BEFORE ASSY. FLARE TINES OF BODY TO .324 MIN./ .330 MAX. DIA.

THIS CONNECTOR IS COVERED BY
U.S. PATENT 3,336,563

PART NO.	QUAN	UOM	DESCRIPTION	CODE	FINISH
68180-1	1		9 HEAT SHRINK TUBING (NOTE 2)		
31-1500 G	1		8 COUPLING NUT		NOTE 1
31-20018	1		7 INSULATOR		NONE
31-10060-1S	1		6 CONTACT		NOTE 1
82-1535-3	1		5 GASKET		NONE
95631	1		4 SPRING WASHER		SEE COMP.
31-914 H	1		3 WASHER		NOTE 1
31-12088-1G	1		2 BODY		NOTE 1
31-1357-5G	1		1 OUTER FERRULE		NOTE 1

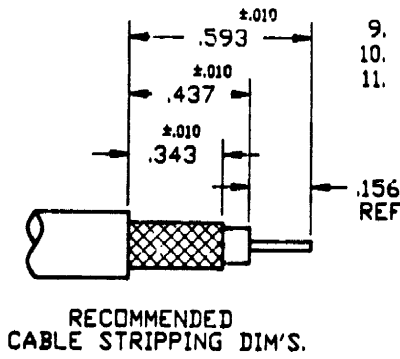

REMOVE ALL BURRS, BREAK CORNERS AND SHARP EDGES TO MAXIMUM UNLESS OTHERWISE SPECIFIED

NOTICE - These drawings, specifications or other data (1) are, and remain the property of Amphenol Corp (2) must be returned upon request, and (3) are confidential and are not to be disclosed to any person other than those to whom they are given by Amphenol Corp. The furnishing of these drawings, specifications, or other data by Amphenol Corp., or by any other person to anyone for any purpose is not to be regarded by implication or otherwise as in any manner licensing, granting rights or permitting such holder or any other person to manufacture, use or sell any product, process or design, patented or otherwise, that may in any way be related to or disclosed by said drawings, specifications or other data.

H:\DEPT611\BNC\000\ASSY\36775		
NEXT ASSY	USED ON	UNLESS OTHERWISE SPECIFIED DIMENSIONS ARE IN INCHES. TOLERANCES NOT OTHERWISE SPECIFIED ARE:
		2 PLACE DECIMAL ±.015 (0.381 mm)
		3 PLACE DECIMAL ±.008 (0.127 mm)
		ANGLES ± 1°
		REFERENCE DRAWING NO.
		FINISH

DRAWN BY	DATE
TERRI ALBERA	9-22-88
J. ROYCE	9-22-88
D.TARRANT	9-22-88
DATE	10/21/91
DATE	10-14-92

TITLE	SCALE	SHEET	OF	ISSUE
BNC PLUG QUICK CRIMP FOR RG58 & 141/U	6:1			W
Amphenol Corporation RF/Microwave Operations Danbury, Conn. U.S.A.				
CODE IDENTIFICATION	DRAWING SIZE	DRAWING NO.		
74868	C	36775		