

# PRODUCT DATA SHEET

Type	Size	Rating	Description	Part No.
Incandescent	G11(G-3½)	6.5V 300mA	11mm Edison screw lamp	G501-5

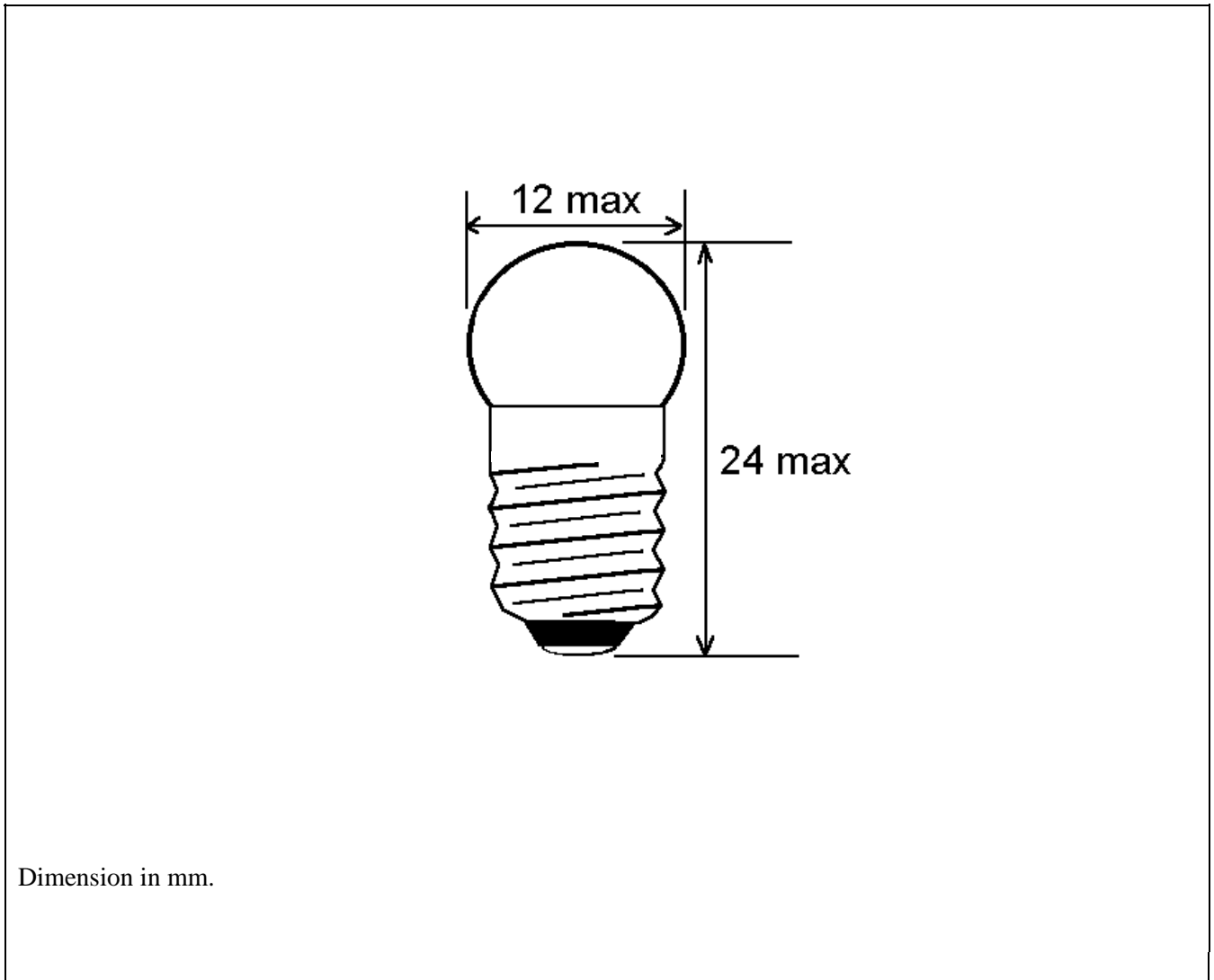

TEST VOLTS	CURRENT (mA)			LIGHT OUTPUT (Lm)			LIFE Hours
	Min.	Nom.	Max.	Min.	Nom.	Max.	
6.5	270	300	330	10	12	14	4,000

**NOTES:**

- 1 RoHS compliant
- 2 Cap type E10/13, nickel plated brass
- 3 Filament shape C-2R
- 4 Cap marking CML 6.5V 300mA

Issue No.	Date	C.N. No.	Drawn	Tech	QA
1	29/08/07	-	BCW		