

## Two-Wire Chopper-Stabilized Hall Effect Latch

### Features and Benefits

- Chopper stabilization
  - Superior temperature stability
  - Extremely low switchpoint drift
  - Insensitive to physical stress
- Reverse battery protection
- Solid-state reliability
- Small size
- Robust EMC capability
- High ESD ratings (HBM)

**Packages: 3 pin SOT23W (suffix LH), and 3 pin SIP (suffix UA)**

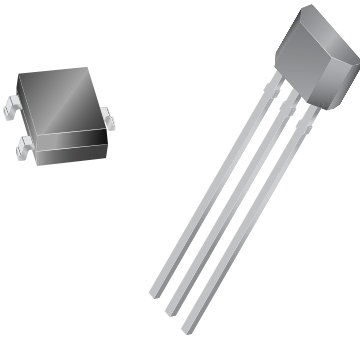

Not to scale

### Description

The A1242 Hall effect latch is a two-wire latch especially suited for operation over extended temperature ranges, from  $-40$  to  $+150^{\circ}\text{C}$ . Superior high-temperature performance is made possible through the Allegro<sup>®</sup> patented dynamic offset cancellation technique, which reduces the residual offset voltage normally caused by device overmolding, temperature dependencies, and thermal stress.

The current-switching output technique allows for the reduction in cost in the wiring harness because only two connections to the device are required. The current-switching output structure also inherently provides more immunity against EMC/ESD transients. These devices have low magnetic thresholds, thereby enabling more flexibility in the magnetic circuit design.

The Hall effect latch will be in the high output current state in the presence of a magnetic South Pole field of sufficient magnitude and will remain in this state until a sufficient North Pole field is present.

The A1242 includes the following on a single silicon chip: a voltage regulator, Hall-voltage generator, small-signal amplifier, chopper stabilization, Schmitt trigger, and a current source output. Advanced BiCMOS wafer fabrication processing takes advantage of low-voltage requirements, component

Continued on the next page...

### Functional Block Diagram

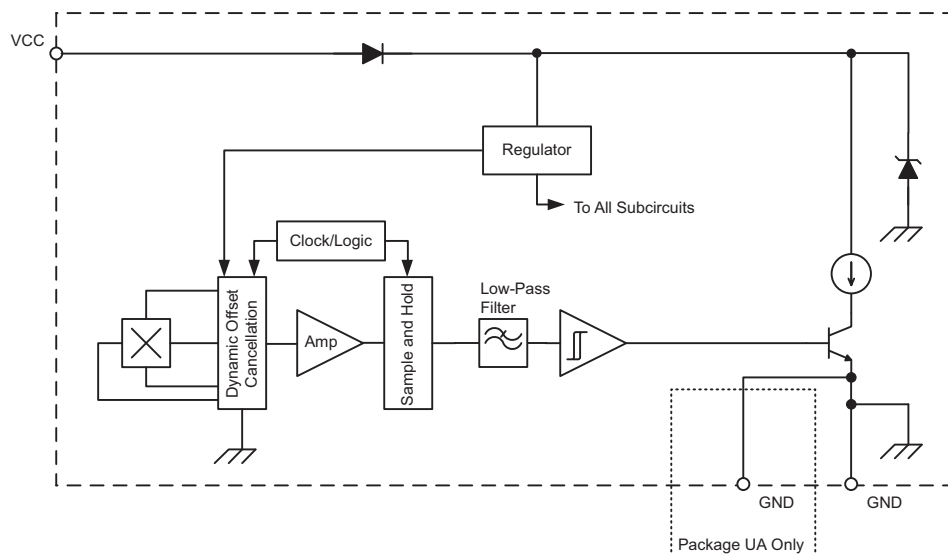

## Description (continued)

matching, very low input-offset errors and small component geometries.

Suffix 'L-' devices are rated for operation over a temperature range of -40°C to +150°C; suffix 'E-' devices are rated for operation over a temperature range of -40°C to +85°C. Two A1242 package styles

provide magnetically optimized solutions for most applications. Package LH is a SOT23W, a miniature low-profile surface-mount package, while package UA is a three-pin ultramini SIP for through-hole mounting. Each package is available lead (Pb) free, with 100% matte tin plated leadframes.

## Selection Guide

Part Number	Packaging*	Mounting	Low Current, I <sub>CC(L)</sub> (mA)	Ambient, T <sub>A</sub> (°C)	B <sub>RP(MIN)</sub> (G)	B <sub>OP(MAX)</sub> (G)
A1242ELHLT-I1-T	7-in. reel, 3000 pieces/reel	3-pin SOT23W surface mount	5.0 to 6.9	-40 to 85	-80	80
A1242ELHLT-I2-T			2.0 to 5.0			
A1242EUA-I1-T	Bulk, 500 pieces/bag	3-pin SIP through hole	5.0 to 6.9	-40 to 150		
A1242LLHLT-I1-T			7-in. reel, 3000 pieces/reel			
A1242LLHLT-I2-T	2.0 to 5.0					
A1242LUA-I1-T	Bulk, 500 pieces/bag	3-pin SIP through hole	5.0 to 6.9			
A1242LUA-I2-T			2.0 to 5.0			

\*Contact Allegro for additional packing options.



## Absolute Maximum Ratings

Characteristic	Symbol	Notes	Rating	Unit*
Supply Voltage	V <sub>CC</sub>		28	V
Reverse Supply Voltage	V <sub>RCC</sub>		-18	V
Magnetic Flux Density	B		Unlimited	G
Operating Ambient Temperature	T <sub>A</sub>	Range E	-40 to 85	°C
		Range L	-40 to 150	°C
Maximum Junction Temperature	T <sub>J(max)</sub>		165	°C
Storage Temperature	T <sub>stg</sub>		-65 to 170	°C

\*1 G (gauss) = 0.1 mT (millitesla)

## Pin-out Diagrams

LH Package

UA Package

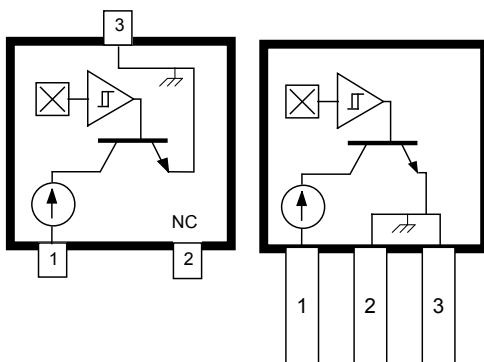

## Terminal List

Name	Number		Function
	Package LH	Package UA	
VCC	1	1	Connects power supply to chip
GND	3	2,3	Ground
NC	2	-	No internal connection

**ELECTRICAL CHARACTERISTICS** over full operating voltage and temperature ranges, unless otherwise specified

Characteristic	Symbol	Test Conditions	Min.	Typ. <sup>1</sup>	Max.	Units
<b>Electrical Characteristics</b>						
Supply Voltage <sup>2 3</sup>	$V_{CC}$	Operating, $T_J < 165^\circ\text{C}$	3.5	–	24	V
Supply Current	$I_{CC(L)}$	-I1, $B < B_{RP}$	5	–	6.9	mA
		-I2, $B < B_{RP}$	2	–	5	mA
	$I_{CC(H)}$	-I1 and -I2, $B > B_{OP}$	12	–	17	mA
Output Slew Rate <sup>4</sup>	$dI/dt$	$R_S = 100 \Omega$ , $C_S = 20 \text{ pF}$ , no bypass capacitor	–	36	–	mA/ $\mu\text{s}$
Chopping Frequency	$f_C$		–	200	–	kHz
Power-On Time	$t_{PO}$	$V_{CC} > V_{CC(MIN)}$	–	–	25	$\mu\text{s}$
Power-On State <sup>5</sup>	POS	$t_{PO} < t_{PO(max)}$ , $dV_{CC}/dt > 25 \text{ mV}/\mu\text{s}$	–	$I_{CC(H)}$	–	–
Supply Zener Clamp Voltage	$V_{Z(supply)}$	$I_{CC} = 20 \text{ mA}$ ; $T_A = 25^\circ\text{C}$	28	–	–	V
Supply Zener Current <sup>6</sup>	$I_{Z(supply)}$	$V_S = 28 \text{ V}$	–	–	20	mA
Reverse Battery Current	$I_{RCC}$	$V_{RCC} = -18 \text{ V}$	–	–	2.5	mA
<b>Magnetic Characteristics<sup>7</sup></b>						
Operate Point	$B_{OP}$	South pole adjacent to branded face of device	5	32	80	G
Release Point	$B_{RP}$	North pole adjacent to branded face of device	-80	-32	-5	G
Hysteresis	$B_{HYS}$	$B_{OP} - B_{RP}$	40	64	110	G

<sup>1</sup> Typical values are at  $T_A = 25^\circ\text{C}$  and  $V_{CC} = 12 \text{ V}$ . Performance may vary for individual units, within the specified maximum and minimum limits.

<sup>2</sup> Maximum voltage must be adjusted for power dissipation and junction temperature; see *Power Derating* section.

<sup>3</sup>  $V_{CC}$  represents the generated voltage between the  $V_{CC}$  pin and the GND pin.

<sup>4</sup> The value of  $dI$  is the difference between 90% of  $I_{CC(H)}$  and 10% of  $I_{CC(L)}$ , and the value of  $dt$  is time period between those two points. The value of  $dI/dt$  depends on the value of the bypass capacitor, if one is used, with greater capacitances resulting in lower rates of change.

<sup>5</sup> For  $t > t_{PO(max)}$ , and  $B_{RP} < B < B_{OP}$ , POS is undefined.

<sup>6</sup> Maximum current limit is equal to the maximum  $I_{CCL(max)} + 3 \text{ mA}$ .

<sup>7</sup> Magnetic flux density,  $B$ , is indicated as a negative value for north-polarity magnetic fields, and as a positive value for south-polarity magnetic fields. This so-called algebraic convention supports arithmetic comparison of north and south polarity values, where the relative strength of the field is indicated by the absolute value of  $B$ , and the sign indicates the polarity of the field (for example, a  $-100 \text{ G}$  field and a  $100 \text{ G}$  field have equivalent strength, but opposite polarity).

## DEVICE QUALIFICATION PROGRAM

Contact Allegro for information.

## EMC (Electromagnetic Compatibility) PERFORMANCE

Contact Allegro for information.

**THERMAL CHARACTERISTICS** may require derating at maximum conditions, see application information

Characteristic	Symbol	Test Conditions*	Value	Units
Package Thermal Resistance	$R_{\theta JA}$	Package LH, minimum-K PCB (single layer, single-sided with copper limited to solder pads)	228	$^{\circ}\text{C}/\text{W}$
		Package LH, low-K PCB (single layer, double-sided with 0.926 in <sup>2</sup> copper area)	110	$^{\circ}\text{C}/\text{W}$
		Package UA, minimum-K PCB (single layer, single-sided with copper limited to solder pads)	165	$^{\circ}\text{C}/\text{W}$

\*Additional information available on the Allegro Web site.

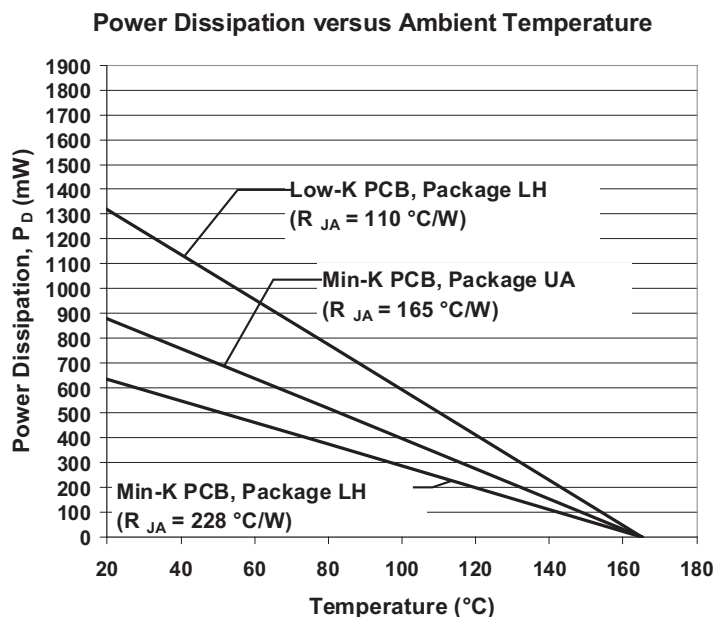
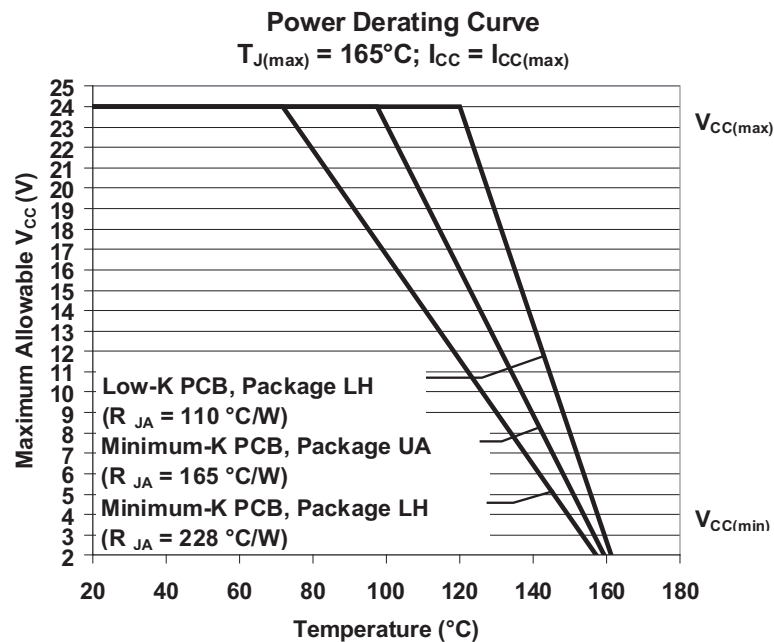

Characteristic Data

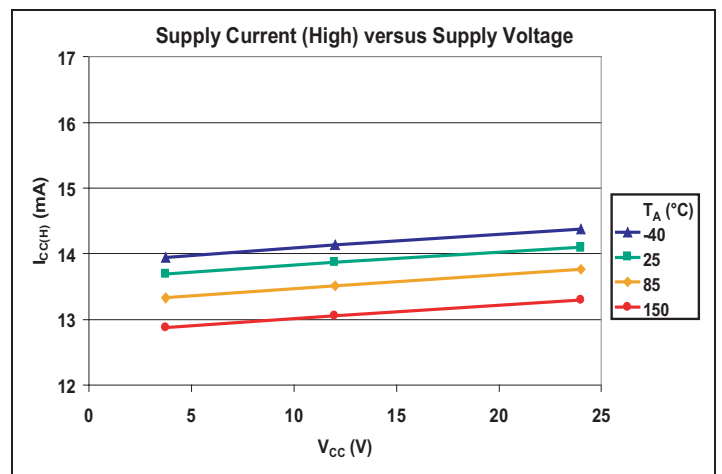
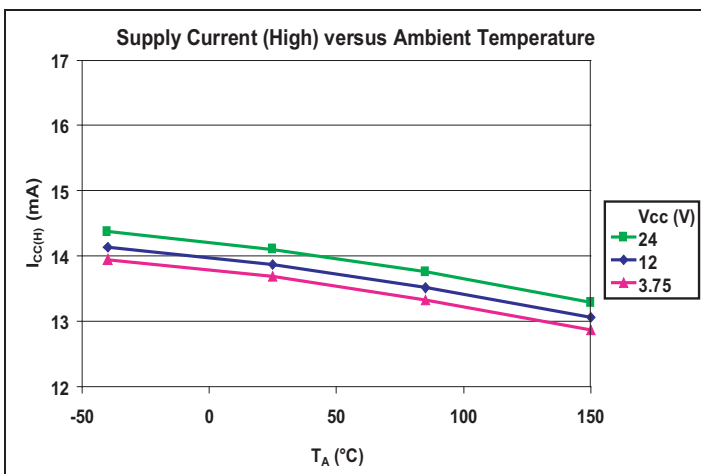
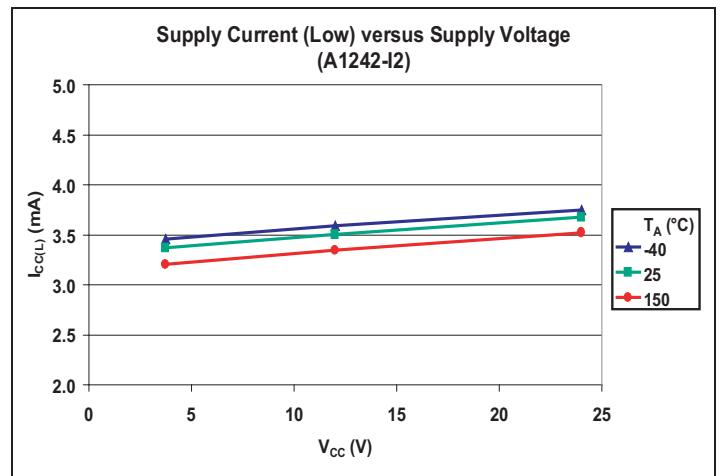
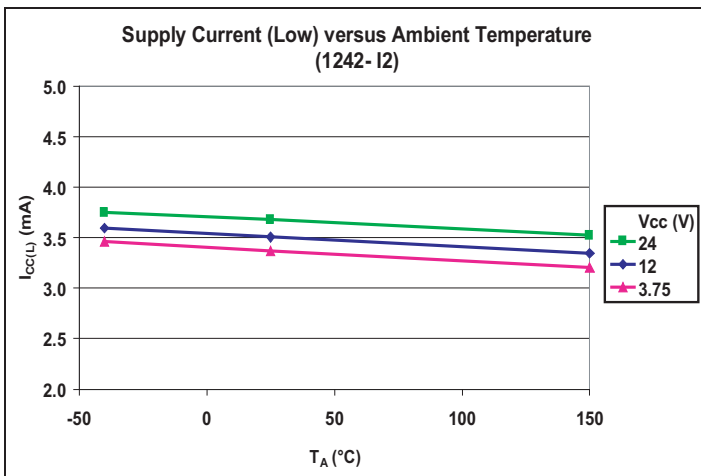
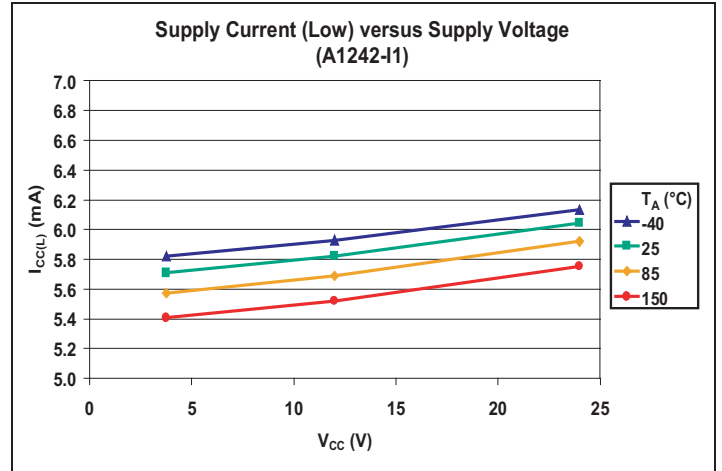
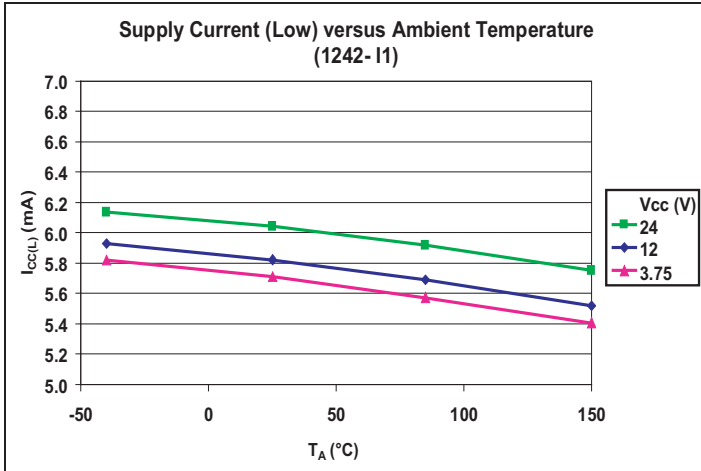

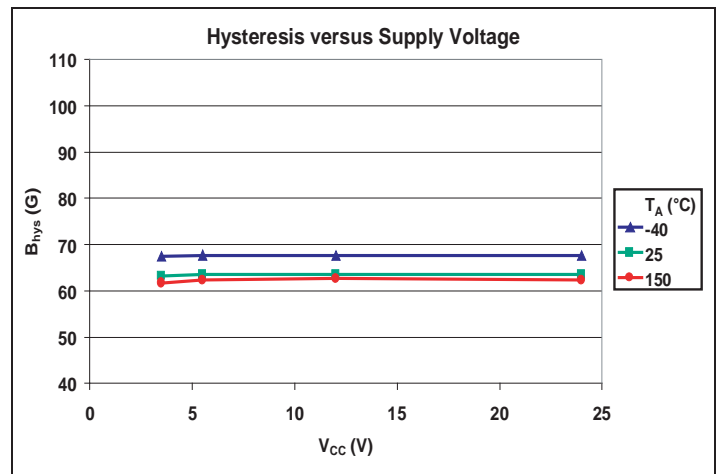
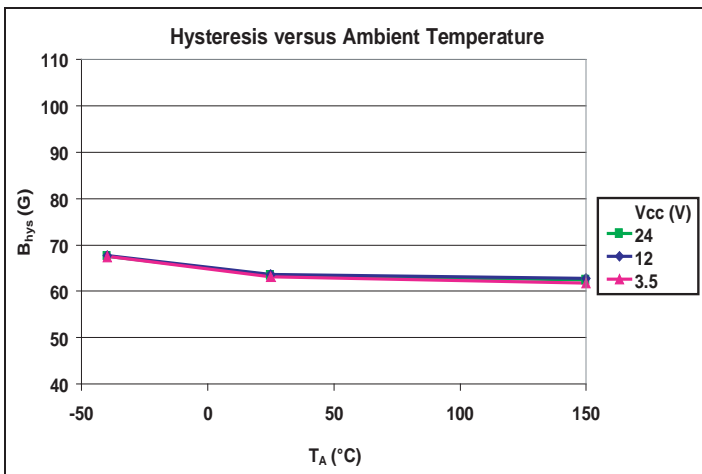
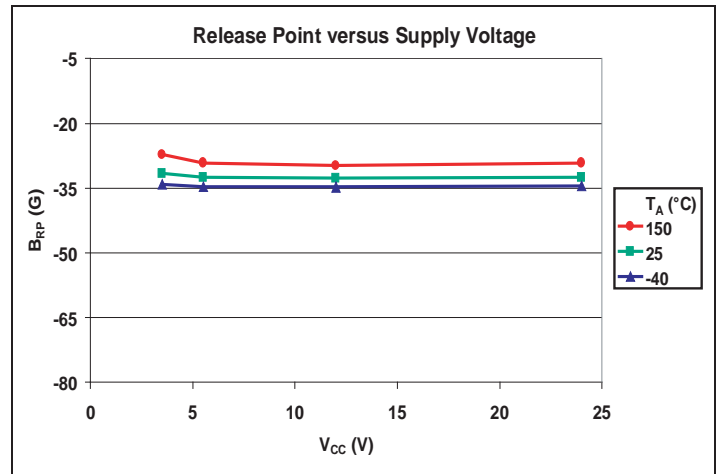
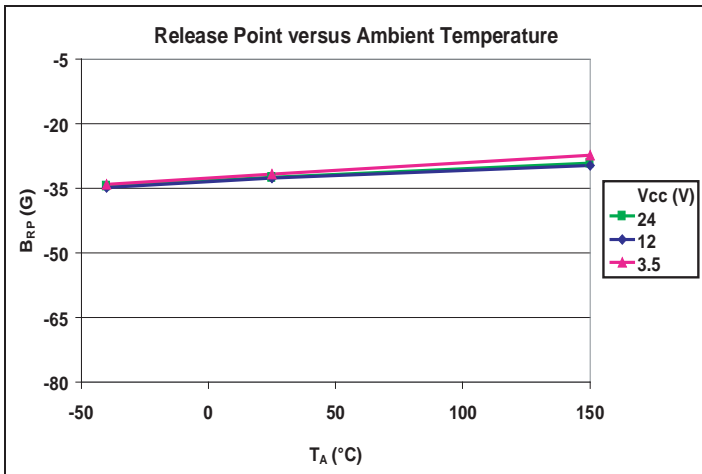
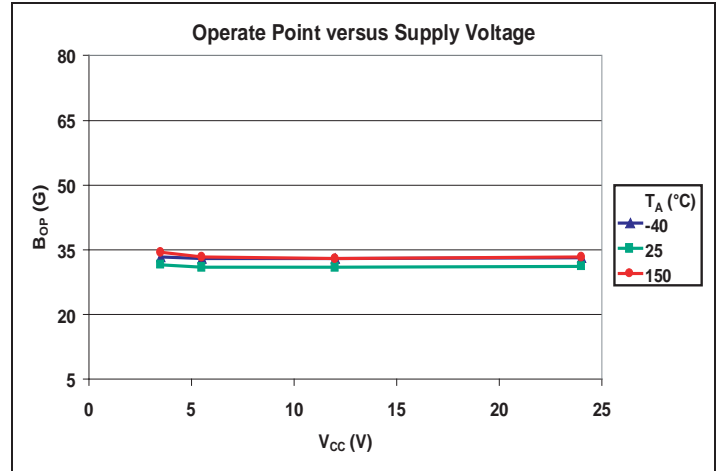
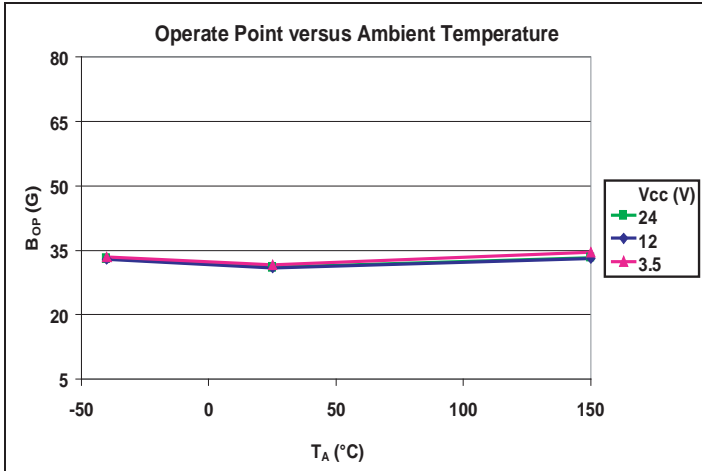

Functional Description

Operation

The output,  $I_{CC}$ , of the A1242 switches to the high current state when a magnetic field perpendicular to the Hall element exceeds the operate point threshold,  $B_{OP}$ . Note that the device latches, that is, a south pole of sufficient strength towards the branded surface of the device switches the device output to  $I_{CC(H)}$ . The device retains its output state if the south pole is removed. When the magnetic field is reduced to below the release point threshold,  $B_{RP}$ , the device output goes to the low current state. The difference between the magnetic operate and release points is called the hysteresis of the device,  $B_{HYS}$ . This built-in hysteresis allows clean switching of the output even in the presence of external mechanical vibration and electrical noise.

Typical Application Circuit

The A1242 should be protected by an external bypass capacitor,  $C_{BYP}$ , connected between the supply,  $V_{CC}$ , and the ground,  $GND$ , of the device.  $C_{BYP}$  reduces both external noise and the noise generated by the chopper-stabilization function. As shown in figure 2, a 0.01  $\mu F$  capacitor is typical.

Installation of  $C_{BYP}$  must ensure that the traces that connect it to the A1242 pins are no greater than 5 mm in length.

All high-frequency interferences conducted along the supply lines are passed directly to the load through  $C_{BYP}$ , and it serves only to protect the A1242 internal circuitry. As a result, the load ECU (electronic control unit) must have sufficient protection, other than  $C_{BYP}$ , installed in parallel with the A1242.

A series resistor on the supply side,  $R_S$  (not shown), in combination with  $C_{BYP}$ , creates a filter for EMI pulses.

When determining the minimum  $V_{CC}$  requirement of the A1242 device, the voltage drops across  $R_S$  and the ECU sense resistor,  $R_{SENSE}$ , must be taken into consideration. The typical value for  $R_{SENSE}$  is approximately 100  $\Omega$ .

Extensive applications information on magnets and Hall-effect devices is available in:

- *Hall-Effect IC Applications Guide*, AN27701,
  - *Guidelines for Designing Subassemblies Using Hall-Effect Devices*, AN27703.1
  - *Soldering Methods for Allegro Products – SMD and Through-Hole*, AN26009
- All are provided in Allegro Electronic Data Book, AMS-702 and the Allegro Web site: [www.allegromicro.com](http://www.allegromicro.com).

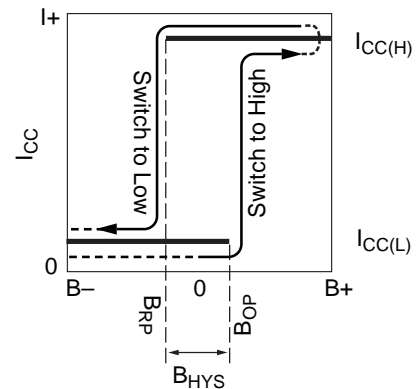

Figure 1. Switching Behavior of the A1242. On the horizontal axis, the B+ direction indicates increasing south polarity magnetic field strength, and the B- direction indicates decreasing south polarity field strength (including the case of increasing north polarity).

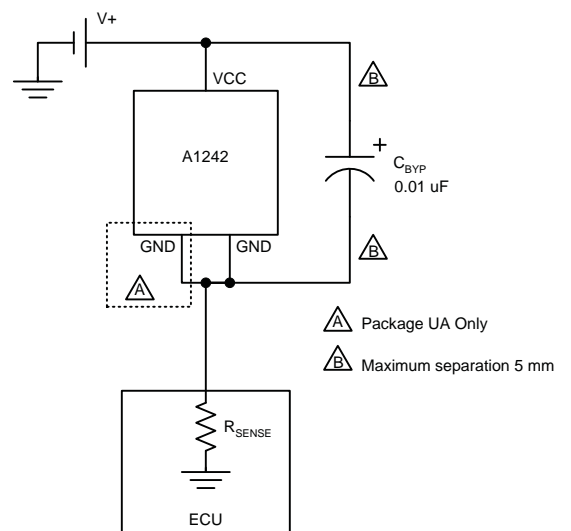

Figure 2. Typical Application Circuit

### Chopper Stabilization Technique

When using Hall-effect technology, a limiting factor for switchpoint accuracy is the small signal voltage developed across the Hall element. This voltage is disproportionately small relative to the offset that can be produced at the output of the Hall element. This makes it difficult to process the signal while maintaining an accurate, reliable output over the specified operating temperature and voltage ranges.

Chopper stabilization is a unique approach used to minimize Hall offset on the chip. The patented Allegro technique, namely Dynamic Quadrature Offset Cancellation, removes key sources of the output drift induced by thermal and mechanical stresses. This offset reduction technique is based on a signal modulation-demodulation process. The undesired offset signal is separated from the magnetic field-induced signal in the frequency domain, through modulation. The subsequent demodulation acts as a modulation process for the offset, causing the magnetic field induced signal to recover its original spectrum at baseband, while the DC offset becomes a high-frequency signal. The magnetic sourced signal then can pass through a low-pass filter, while the modulated DC offset is suppressed. This configuration is illustrated in Figure 3.

The chopper stabilization technique uses a 200 kHz high frequency clock. For demodulation process, a sample and hold

technique is used, where the sampling is performed at twice the chopper frequency (400 kHz). This high-frequency operation allows a greater sampling rate, which results in higher accuracy and faster signal-processing capability. This approach desensitizes the chip to the effects of thermal and mechanical stresses, and produces devices that have extremely stable quiescent Hall output voltages and precise recoverability after temperature cycling. This technique is made possible through the use of a BiCMOS process, which allows the use of low-offset, low-noise amplifiers in combination with high-density logic integration and sample-and-hold circuits.

The repeatability of magnetic field-induced switching is affected slightly by a chopper technique. However, the Allegro high frequency chopping approach minimizes the affect of jitter and makes it imperceptible in most applications. Applications that are more likely to be sensitive to such degradation are those requiring precise sensing of alternating magnetic fields; for example, speed sensing of ring-magnet targets. For such applications,

Allegro recommends its digital device families with lower sensitivity to jitter. For more information on those devices, contact your Allegro sales representative.

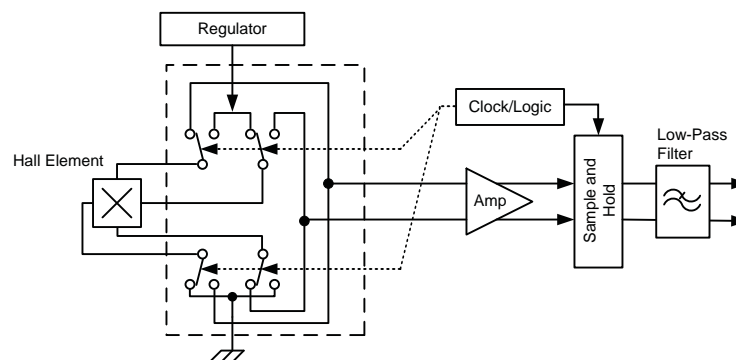

Figure 3. Chopper stabilization circuit (dynamic quadrature offset cancellation)



## Power Derating

## Power Derating

The device must be operated below the maximum junction temperature of the device,  $T_{J(\max)}$ . Under certain combinations of peak conditions, reliable operation may require derating supplied power or improving the heat dissipation properties of the application. This section presents a procedure for correlating factors affecting operating  $T_J$ . (Thermal data is also available on the Allegro MicroSystems Web site.)

The Package Thermal Resistance,  $R_{\theta JA}$ , is a figure of merit summarizing the ability of the application and the device to dissipate heat from the junction (die), through all paths to the ambient air. Its primary component is the Effective Thermal Conductivity,  $K$ , of the printed circuit board, including adjacent devices and traces. Radiation from the die through the device case,  $R_{\theta JC}$ , is a relatively small component of  $R_{\theta JA}$ . Ambient air temperature,  $T_A$ , and air motion are significant external factors, damped by overmolding.

The effect of varying power levels (Power Dissipation,  $P_D$ ), can be estimated. The following formulas represent the fundamental relationships used to estimate  $T_J$ , at  $P_D$ .

$$P_D = V_{IN} \times I_{IN} \quad (1)$$

$$\Delta T = P_D \times R_{\theta JA} \quad (2)$$

$$T_J = T_A + \Delta T \quad (3)$$

For example, given common conditions such as:  $T_A = 25^\circ\text{C}$ ,  $V_{CC} = 12\text{ V}$ ,  $I_{CC} = 6\text{ mA}$ , and  $R_{\theta JA} = 165\text{ }^\circ\text{C/W}$ , then:

$$P_D = V_{CC} \times I_{CC} = 12\text{ V} \times 6\text{ mA} = 72\text{ mW}$$

$$\Delta T = P_D \times R_{\theta JA} = 72\text{ mW} \times 165\text{ }^\circ\text{C/W} = 12^\circ\text{C}$$

$$T_J = T_A + \Delta T = 25^\circ\text{C} + 12^\circ\text{C} = 37^\circ\text{C}$$

A worst-case estimate,  $P_{D(\max)}$ , represents the maximum allowable power level ( $V_{CC(\max)}$ ,  $I_{CC(\max)}$ ), without exceeding  $T_{J(\max)}$ , at a selected  $R_{\theta JA}$  and  $T_A$ .

*Example:* Reliability for  $V_{CC}$  at  $T_A = 150^\circ\text{C}$ , package LH, using minimum-K PCB.

Observe the worst-case ratings for the device, specifically:  $R_{\theta JA} = 228^\circ\text{C/W}$ ,  $T_{J(\max)} = 165^\circ\text{C}$ ,  $V_{CC(\max)} = 24\text{ V}$ , and  $I_{CC(\max)} = 17\text{ mA}$ .

Calculate the maximum allowable power level,  $P_{D(\max)}$ . First, invert equation 3:

$$\Delta T_{\max} = T_{J(\max)} - T_A = 165^\circ\text{C} - 150^\circ\text{C} = 15^\circ\text{C}$$

This provides the allowable increase to  $T_J$  resulting from internal power dissipation. Then, invert equation 2:

$$P_{D(\max)} = \Delta T_{\max} \div R_{\theta JA} = 15^\circ\text{C} \div 228\text{ }^\circ\text{C/W} = 66\text{ mW}$$

Finally, invert equation 1 with respect to voltage:

$$V_{CC(\text{est})} = P_{D(\max)} \div I_{CC(\max)} = 66\text{ mW} \div 17\text{ mA} = 3.9\text{ V}$$

The result indicates that, at  $T_A$ , the application and device can dissipate adequate amounts of heat at voltages  $\leq V_{CC(\text{est})}$ .

Compare  $V_{CC(\text{est})}$  to  $V_{CC(\max)}$ . If  $V_{CC(\text{est})} \leq V_{CC(\max)}$ , then reliable operation between  $V_{CC(\text{est})}$  and  $V_{CC(\max)}$  requires enhanced  $R_{\theta JA}$ . If  $V_{CC(\text{est})} \geq V_{CC(\max)}$ , then operation between  $V_{CC(\text{est})}$  and  $V_{CC(\max)}$  is reliable under these conditions.

Package LH, 3-Pin (SOT-23W)

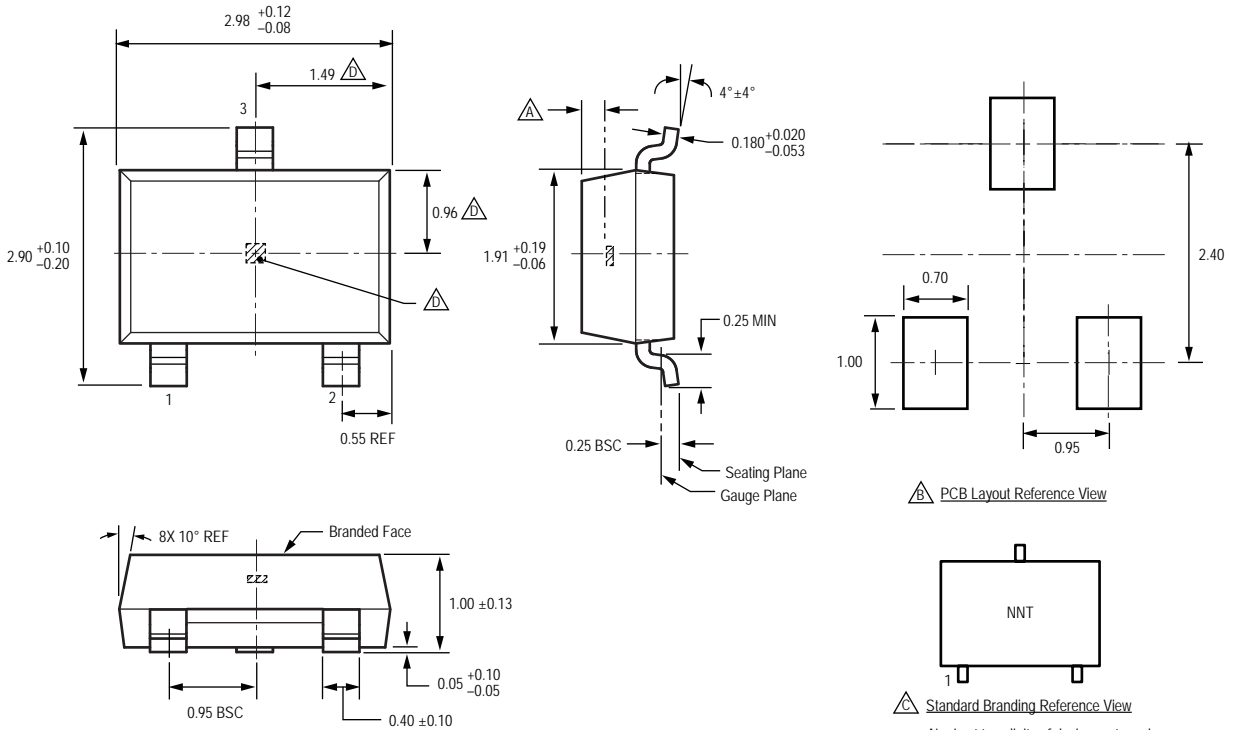

For Reference Only; not for tooling use (reference dwg. 802840)  
 Dimensions in millimeters  
 Dimensions exclusive of mold flash, gate burrs, and dambar protrusions  
 Exact case and lead configuration at supplier discretion within limits shown

- $\Delta$  Active Area Depth, 0.28 mm REF
- $\Delta$  Reference land pattern layout  
 All pads a minimum of 0.20 mm from all adjacent pads; adjust as necessary to meet application process requirements and PCB layout tolerances
- $\Delta$  Branding scale and appearance at supplier discretion
- $\Delta$  Hall element, not to scale

N = Last two digits of device part number  
 T = Temperature code

Package UA, 3-Pin SIP

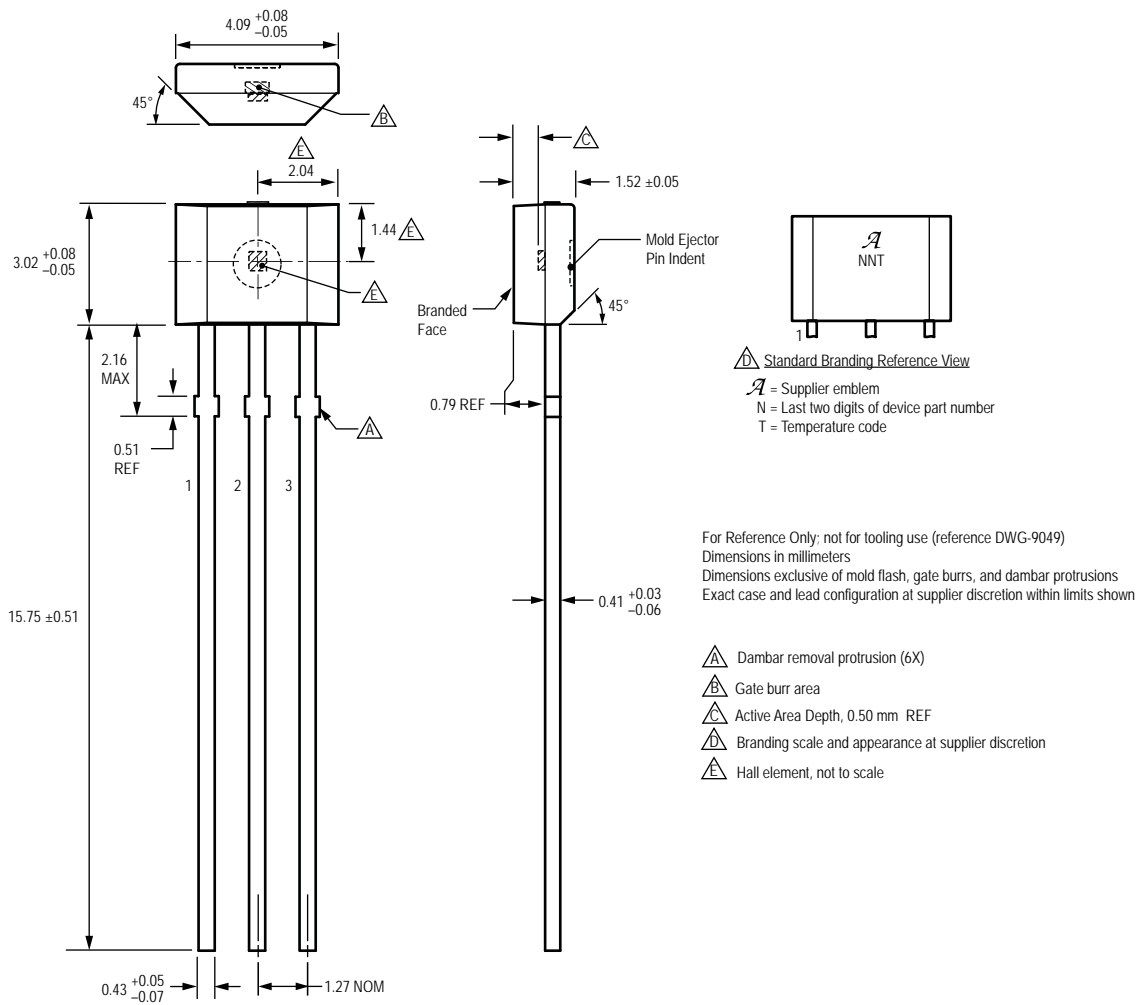

Copyright ©2005-2010, Allegro MicroSystems, Inc.

Allegro MicroSystems, Inc. reserves the right to make, from time to time, such departures from the detail specifications as may be required to permit improvements in the performance, reliability, or manufacturability of its products. Before placing an order, the user is cautioned to verify that the information being relied upon is current.

Allegro's products are not to be used in life support devices or systems, if a failure of an Allegro product can reasonably be expected to cause the failure of that life support device or system, or to affect the safety or effectiveness of that device or system.

The information included herein is believed to be accurate and reliable. However, Allegro MicroSystems, Inc. assumes no responsibility for its use; nor for any infringement of patents or other rights of third parties which may result from its use.

For the latest version of this document, visit our website:

[www.allegromicro.com](http://www.allegromicro.com)

