

# PRECISION MULTIDIALS

## MODELS 11/15/16/21



597-995 to 598 045

### ORDERING CODE

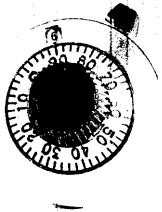

**MODEL 11**

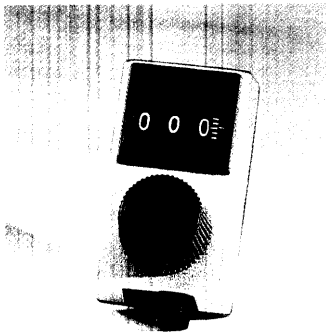
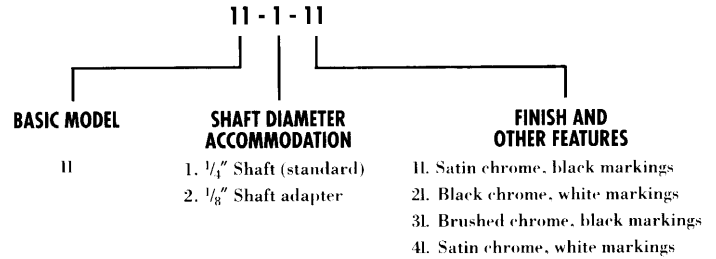
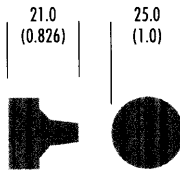

**MODEL 15**

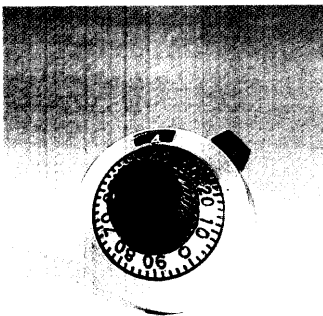
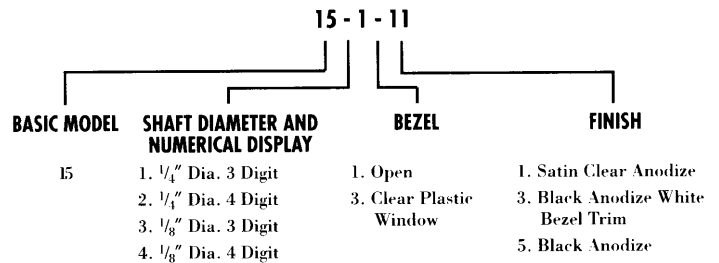
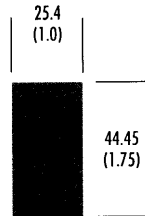

**MODEL 16**

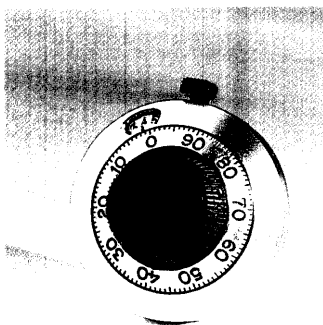
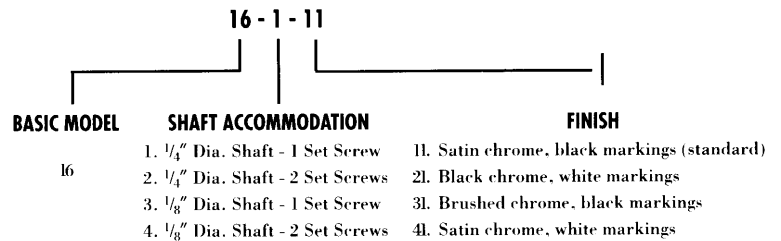
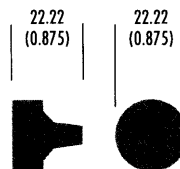

**MODEL 21**

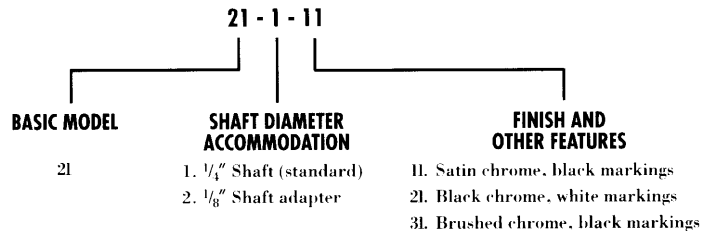
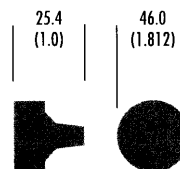

The part number consists of three groups of digits. The first is the **SPECTROL Model number**. The second group describes the shaft diameter with which the dial is to be used. The third group describes the exterior finish, markings and other features.

# Specifications

## MODEL 11

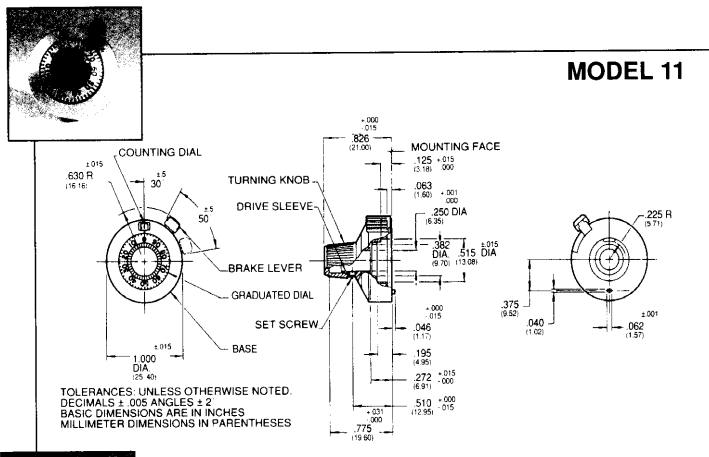

### INDICATION

### ROTATION RUNOUT

### OPERATION

### ACCURACY

### MOUNTING

### TRANSFER POINT

### NUMERAL SIZE

### GRADUATED SIZE

### WEIGHT

### MOUNTING HARDWARE

Single counter type wheel and a graduated circular dial registering a total count of 10 turns

Increasing indication: CW direction Decreasing indication: CCW direction

Dial to be free running and without binds with axis of drive sleeve perpendicular or in any position within .004 per inch (0.10) out of perpendicular with the mounting face

Single numeral in window (0 thru 10) indicates completed number of turns of the drive sleeve. Graduated circular dial indicates the percent of a partial turn of the drive sleeve

Zero backlash between graduated dial and the drive sleeve

Directly to shaft with #2-56 spline socket set screw. Drive sleeve set screw on lower side of vertical centre line with a graduated circular dial reading of 0

Between 97 and 0

.075 high (1.90) x .013 width (0.33) of line

Numeral graduations .040 long (1.02) intermediate graduation .030 long (0.76). Width of graduations .010 (0.25)

0.7 oz. max. (19.84 gm)

Lock washer; internal tooth, steel, nickel plated panel nut: brass, nickel plated

## MODEL 15

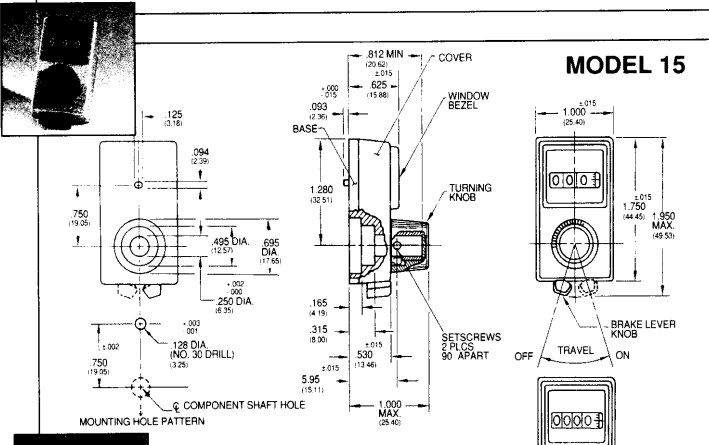

### OPERATION 3 Digit: (10 turn)

### 4 Digit: (100 turn)

### ACCURACY

### ROTATION

### NUMERALS

### PHASING

### MOUNTING

### WEIGHT

The left digit indicates the number of complete revolutions of the turning knob and the right two digits indicate the percent of a revolution. The unit registers a total count of 999

The left two digits indicate the number of complete revolutions of the turning knob and the right two digits indicate the percent of a revolution. The unit registers a total count of 9999

Graduation lines adjacent to the numerals on the right digit wheel indicate settings of .2% of a revolution of the turning knob

The indication shall increase with clockwise rotation of the turning knob

The numerals shall be white on a black background and .130 high (3.30)

The dial shall have the feature of being phased during the mounting operation by rotating the exposed component shaft to correspond with the desired reading on the dial prior to tightening the set screws

The spring detented knob shall be removed using a straight pull, exposing two No. 4-40 hex socket set screws for mounting the dial directly to the component shaft. 1.6 ounces (45.36 gm)

## MODEL 16

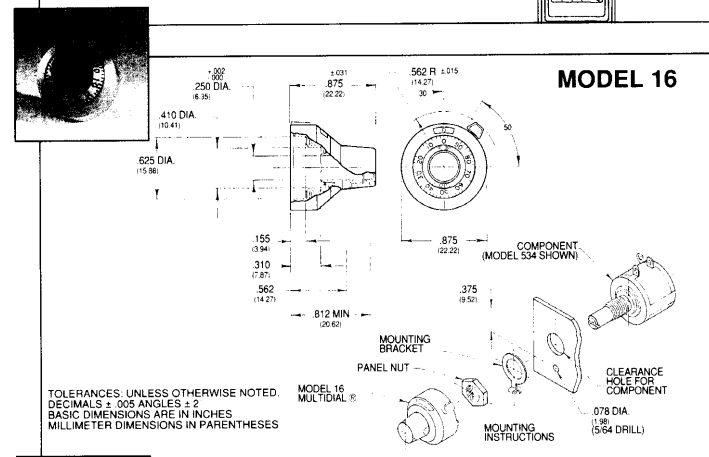

### READOUT AND OPERATION

### TRANSFER POINT

### ROTATION

### BRAKE LEVER

### ACCURACY

### MOUNTING

### NUMERAL SIZE

### GRADUATION SIZE

### WEIGHT

Unit shall register a total count of 15 turns. The number in the window (0 thru 14) indicates completed number of turns of the drive sleeve. Graduated circular dial indicates the percent of a partial turn of the drive sleeve

The number in centre of window shall change as graduated dial rotates between 95 and 0

Readout shall increase with clockwise and decrease with counterclockwise rotation

1st Position (15° movement of Brake Lever) operates a high torque system for fine adjustment; 2nd Position (15° additional movement of Brake Lever) actuates brake

Backlash shall be zero between graduated dial and drive sleeve

Install mounting bracket between panel and panel nut. Multidial shall mount directly to shaft with No. 2-56 spline socket set screw, located adjacent to No. 50 on graduated dial

.075 high

Numeral graduations .045 long (1.14) intermediate graduations .030 long (0.76)

0.7 oz. max. (19.84 gm)

## MODEL 21

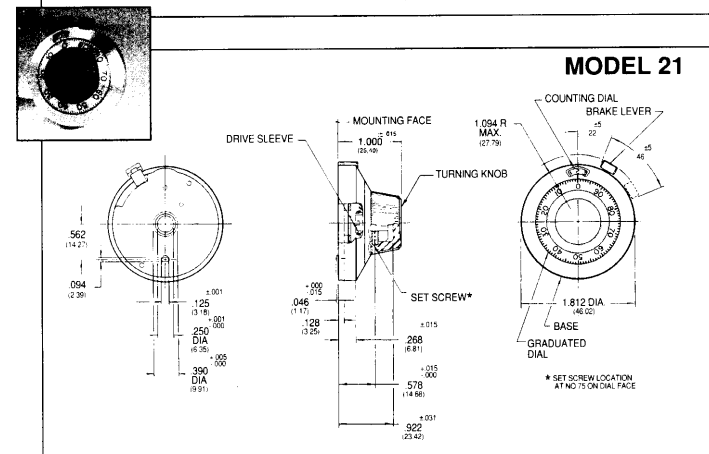

### READOUT AND OPERATION

### TRANSFER POINT

### ROTATION

### ACCURACY

### MOUNTING

### NUMERAL SIZE

### GRADUATION SIZE

### WEIGHT

Unit shall register a total count of 1499. The number in centre of window (0 thru 14) indicates completed number of turns of the drive sleeve. The graduated circular dial indicates the percent of a partial turn of the drive sleeve

The number in centre of window shall change as graduated dial rotates between 94 and 0

Readout shall increase with clockwise and decrease with counterclockwise rotation

Backlash shall be zero between graduated dial and drive sleeve

Unit shall mount directly to shaft with no. 4-40 hex socket set screw located adjacent to no. 75 on graduated dial

Counter wheel:

.090 high x 0.13 (2.29 x 0.33)

Graduated dial:

.109 high x .018 (2.77 x 0.46)

Numeral and every fifth graduation .055 (1.40)

long, intermediate graduations .035 long (0.89)

Width of graduation .012 (0.30)

3.0 oz. max. (85.05 gm)

ISO 9001



FM 26189



A Kearney-National Company

As a general policy Spectrol does not recommend the use of any of its products in life support applications where failure or malfunction of the Spectrol product can be reasonably expected to cause failure of the life support device or to significantly affect its safety or effectiveness.